

HONDA
MARINE

OUTBOARD MOTOR

BF2.3DH

PARTS CATALOGUE

1

FOREWORD INDEX

1

ENGINE GROUP

2

FRAME GROUP

3

PART NUMBER INDEX

4

PART NAME INDEX

5

Instruction for use of parts catalogue

- **This parts catalogue was prepared based on the latest information available as of April 01, 2015.**
 - See the parts catalogue news for any revision that is made after April 01, 2015.
- **Always specify the part number when ordering a part.**
 - Check the model, type, serial numbers, color, maker, and the size as needed before ordering a part.
 - Note that the illustrations (part drawings) can differ from the actual parts in shape. They are given just to help you to refer to the parts.
- **When modifications or additions to this parts catalogue are made, a revised edition will be issued at an appropriate time, with successively progressing revision numbers on the cover. We recommend obtaining such revisions in order to keep your parts catalogue up-to-date at all times. To check whether a parts catalogue revision has been issued, please contact your Honda distributor.**

Initial version issue date April 01, 2015
Honda Motor Co., Ltd.

CONTENTS

	Page
● Instruction for use of parts catalogue	1
● How to refer to the part information	2
● Part catalogue structure	3
● When the parts were revised.....	4
● Abbreviations used in the parts catalogue.....	4
● How to check the part block and serial numbers.....	5
● Models, parts catalogue codes and applicable serial numbers.....	6
● Features of each type.....	6
● Fuel hose, general purpose hoses and vinyl hose	7
● FLAT RATE SERVICE TIME	8
● Illustrated index	13
● ENGINE GROUP.....	16
● FRAME GROUP.....	33
● PART NO. INDEX.....	42
● PART NAME INDEX.....	44

How to refer to the part information

A Reference with "Illustrated index"

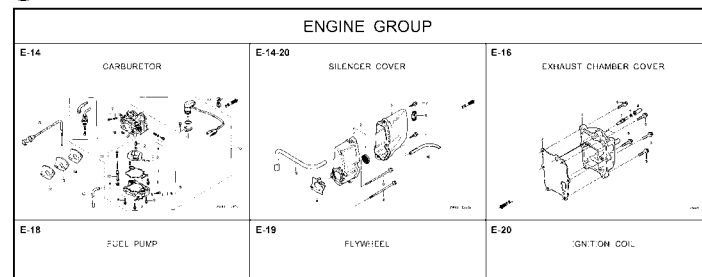

B Reference with "Part number index"

PART NO. INDEX				
Part Number	Page Ref.	Part Number	Page Ref.	Pi
06000		15212-ZW9-000	49 7	17583
		15220-ZW9-003	49 8	17583
06316-ZW9-000	104 1	15332-ZW9-000	74 2	17611
		15332-ZW9-A30	76 2	17611
11000		15400-PFB-004	46 5	17612
		15422-ZW9-000	49 9	17620
11300-ZW9-000	46 1	15473-881-000	49 10	17620
11300-ZW9-800	46 1	15474-ZW9-000	49 11	17624
11340-ZW9-000	46 2	15611-921-000	45 6	17650
11342-ZW9-000	46 3	15655-ZW9-000	46 6	
11381-ZW9-003	47 1			17660
				17661
12000		16000		
		16010-ZV4-005	55 1	17665
12000-ZW9-000ZA	46 4	16011-ZV4-005	55 2	17670
12155-ZV4-A00	48 1	16013-ZW9-003	55 3	17680
12166-ZW9-000	45 1	16016-ZW9-003	55 4	
12209-6B4-681	51 1	16016-ZW9-721	55 4	17701
12210-ZW9-000ZA	45 2	16023-ZW9-003	55 5	17701
12216-ZE2-300	74 1	16024-ZV4-650	55 6	17701
		16028-ZV4-650	55 7	17702

C Reference with "Part name index"

PART NAME INDEX		
Part name	Page	Ref.
[A]		
ABSORBER, FUEL	80	5
ARMATURE COMP.	62	7
ARM COMP., LINK JOINT	102	18
ARM COMP., SHIFT LINK	102	14
ARM COMP., TILT	97	20
ARM, FUEL PUMP ROCKER	51	4
ARM, REVERSE LOCK	97	18
ARM, SHIFT LINK	92	7
ARM, STOPPER	52	12
ARM, THROTTLE REMOTE	92	6
ARM, VALVE ROCKER	51	3
[B]		
BAG, TOOL, 160MM	101	10
BAND	103	37
BAND B1, WIRE	37	1
BAND, CORD	35	18
BAND, TUBE CLIP, 11MM	31	20
BAND, TUBE CLIP, 12.5MM	31	19

E-2 CYLINDER HEAD

Ref No.

Ref. No.	Part No.	Description	Reqd. QTY						Serial No.	Parts catalogue code
			9901	9901	1001	1001	1001	1001		
1	12166-ZW9-000	STOPPER, ENGINE SIDE	2	2	2	2	2	2		
2	12210-ZW9-000ZA	HEAD COMP., CYLINDER	1	1	1	1	1	1		
3	12251-ZW9-003	GASKET, CYLINDER HEAD	1	1	1	1	1	1		
4	12310-ZW9-000	COVER COMP., HEAD	1	1	1	1	1	1		
5	12312-ZW9-000	PACKING, HEAD COVER	1	1	1	1	1	1		
6	15611-921-000	CAP, OIL (NO GAUGE)	1	1	1	1	1	1		
7	16617-ZW9-000	HOLDER, CABLE	1	1	1	1	1	1	SC,SG	
	16617-ZW9-010		1	1	1	1	1	1	1001800 LHC,LHD	
			1	1	1	1	1	1	1001801 LHC,LHD	
8	35673-ZW5-003	SENSOR ASSY., WATER	1	1	1	1	1	1		
9	90003-ZW9-000	BOLT, FLANGE, 6X22	4	4	4	4	4	4		
10	90007-ZW9-003	BOLT, FLANGE, 8X83	6	6	6	6	6	6		
11	90011-ZW9-000	BOLT, FLANGE, 6X14(CT200)	1	1	1	1	1	1		
12	90020-ZW9-000	BOLT, FLANGE, 8X40	2	2	2	2	2	2		
13	91202-KJ9-003	OIL SEAL, 30X32X6	1	1	1	1	1	1		
14	91301-805-000	O-RING, 26X2.7	1	1	1	1	1	1		
15	91307-PK2-005	O-RING, 9.5X1.5(HONDA KIKAKI)	1	1	1	1	1	1		
16	98059-55916	PLUG, SPARK (CR5EH-9)	2	2	2	2	2	2		
	98059-55926	PLUG, SPARK (U16FER9)	2	2	2	2	2	2		

2000.09.20 E

Page No.

Part catalogue structure

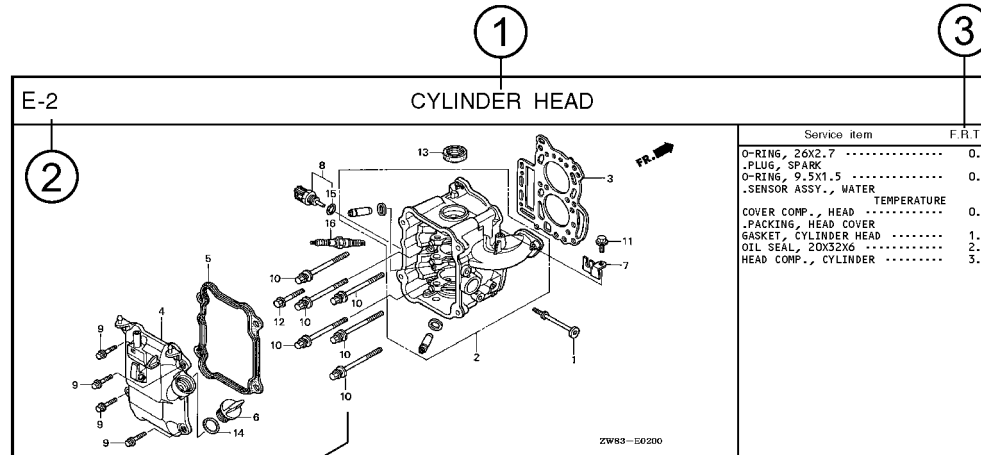

Ref. No.	Part No.	Description	Reqd. QTY						Serial No.	Parts catalogue code
			BF 9.9D1	BFF 9.9D1	BF 10D1	BFF 10D1	BF 10B1	BFF 10B1		
1	12166-ZW9-000	STOPPER, ENGINE SIDE	2	2	2	2	2			
2	12210-ZW9-000ZA	HEAD COMP., CYLINDER								
		NH8 DARK GRAY	1	1	1	1	1			
3	12251-ZW9-003	GASKET, CYLINDER HEAD	1	1	1	1	1			
4	12310-ZW9-000	COVER COMP., HEAD	1	1	1	1	1			
5	12312-ZW9-000	PACKING, HEAD COVER	1	1	1	1	1			
6	15611-921-000	CAP, OIL	1	1	1	1	1			
		(NO GAUGE)								
7	16617-ZW9-000	HOLDER, CABLE	1	1	1	1	1	SC,SG		
	16617-ZW9-010		1	1	1	1	1	1001800 LHC,LHD		

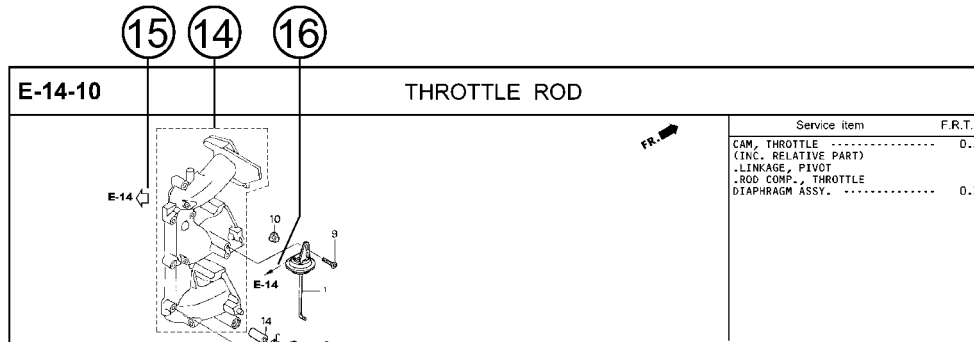

① Block title ② Block number

③ Service item/Flat rate time

④ Reference number

- Title number marked with the parenthesis or parentheses indicates that it continues from the previous page.

⑤ Part number ⑥ Honda color code

⑦ Description

⑧ Assemblies

- Sections framed with broken lines in the exploded view drawings are available as complete assemblies. (Their individual parts can also be obtained.)

⑨ Color description

⑩ Note

- Notes are shown with the parentheses in the part name column.

⑪ Required quantity

- Required QTY shown in the parenthesis or parentheses indicates the optional part.
- Required QTY marked with "N" Indicates the optional part that should be selected as needed.
- Required QTY indicates the number of the part used in the block.

⑫ Serial number

⑬ Type

- When the type column is blank, it indicates that the part is applicable to all types.
- As the type of the actual unit may differ from the "parts catalogue, type" please refer to "Models, types and applicable serial numbers" for confirmation.

⑭

- Parts enclosed within a dotted line are covered in a different block.

⑮

- A hollow arrow indicates the block No. for the parts enclosed within a dotted line.

⑯

- A solid arrow indicates the block No. the part in question is connected to.

When the parts were revised



Be sure to check the serial number!!



Ref. No.	Part No.	Description	Reqd. QTY						Serial No.
			BF 9.9D1	BFP 9.9D1	BF 10D1	BFP 10D1	BF 10B1	BFP 10B1	
1	12166-ZW9-000	STOPPER, ENGINE SIDE	2	2	2	2	2	2	
2	12210-ZW9-000ZA	HEAD COMP., CYLINDER							
		NH8.....DARK GRAY	1	1	1	1	1	1	
3	12251-ZW9-003	GASKET, CYLINDER HEAD	1	1	1	1	1	1	
4	12310-ZW9-000	COVER COMP., HEAD	1	1	1	1	1	1	
5	12312-ZW9-000	PACKING, HEAD COVER	1	1	1	1	1	1	
6	15611-921-000	CAP, OIL (NO GAUGE)	1	1	1	1	1	1	
7	16617-ZW9-000	HOLDER, CABLE (###)	1	1	1	1	1	1	
	16617-ZW9-010		1	1	1	1	1	1	

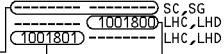

The number has been used from the initial model without revision. When shown at the left side, it is applicable to the models of No.1001801 and the subsequent numbers. When shown at the right side, it is applicable to the models up to No.1001800.

• The parts listed with "###" at the end of the parts name have limited supply period (parts not for sale).

Abbreviations used in the parts catalogue

• The following abbreviations are used in the parts name column.

- A Ampere
- A.C. Alternating current
- ASSY. Assembly
- AT. Automatic transmission
- C.D.I. Capacitive discharge ignition
- COMP. ... Complete
- D.C. Direct current
- EX. Exhaust
- G.F.C.I ... Ground fault circuit interruptor
- HEX. Hexagonal
- H.S.T. Hydrostatic transmission
- FR.Front
- IN.Inlet
- L (100L) .Link (100 Links)
- L.Left
- MMMillimeter
- MT.Manual Transmission
- P.T.O.Power take off
- R.Right
- RR.Rear
- STD.Standard
- T (22T) ...Tooth (22 Teeth)
- VVolt
- WWatt

How to check the part block and serial numbers

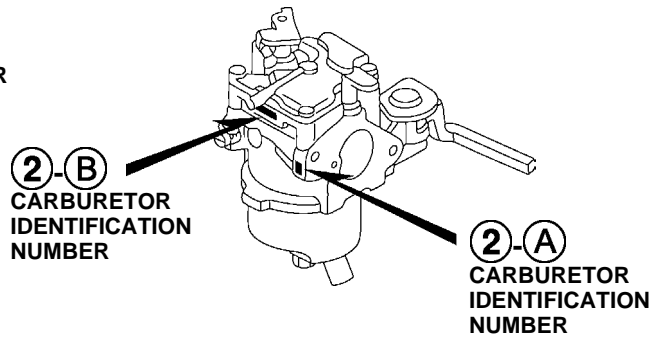
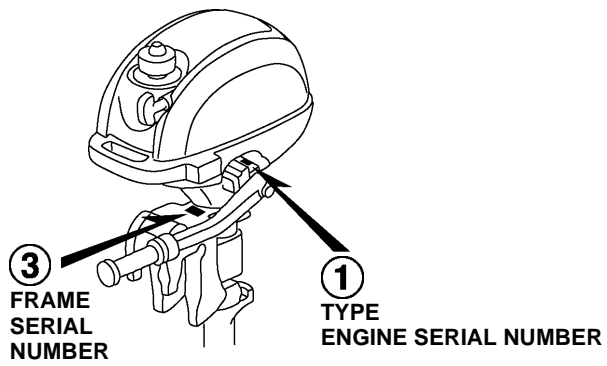
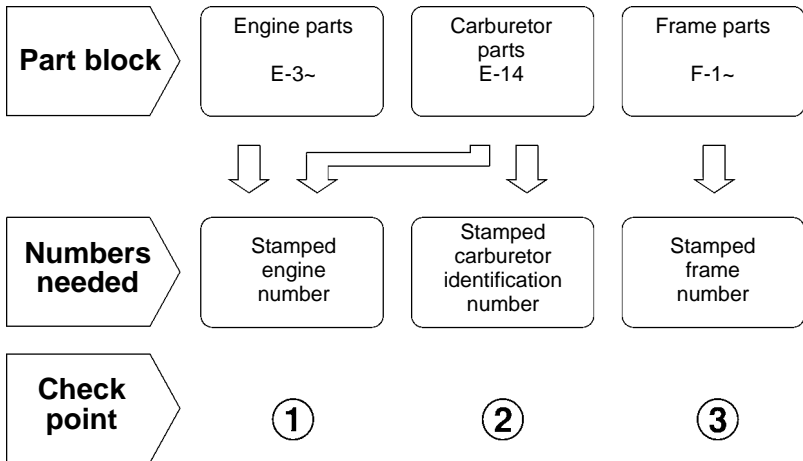

Models, parts catalogue codes and applicable serial numbers

- Models, parts catalogue codes and applicable serial Nos. given in this parts catalogue can be identified as follows.

Model	Type	Parts catalogue type	Engine		Applicable engine serial No.	Applicable frame serial No.	Applicable carburetor identification No.
			Model	Type			
BF2.3DH (1)	LCHD	LCHD	BF2.3DH	SE1	BEABC-1000001~	BABC-1000001~	BF33T A
	LCHU	LCHU		SE3			BF33V A
	SCHD	SCHD		SE1			BF33T A
	SCHU	SCHU		SE3			BF33V A
BF2.3DH (2) (China)	SCHH	SCHH	BF2.3DH	SE1	BEABC-1000001~	BABC-1000001~	BF33T A

* Of carburetor identification numbers, only the portions underlined in the example below are used for registration.

BF 33T A KC ナ
Ⓐ Ⓑ

Features of each type

- See the following table for the features of each type. (Items in brackets are optional)

Specifications	Model Type	BF2.3DH (1)				BF2.3DH (2)
		LCHD	LCHU	SCHD	SCHU	SCHH
Transom height	418mm			●	●	●
	571mm	●	●			

Fuel hose, general purpose hoses and vinyl hose

- The standard part fuel hose, general purpose hose and vinyl hose may be substituted by the coiled bulk part.
- When ordering the standard part fuel hose, general purpose hose and vinyl hose use the bulk part number written in the parts catalog in brackets () underneath the part name.
- When exchanging the hose, cut and use at the specified length as mentioned in the part name.
(For the method of cutting the bulk part, and method of filling out orders etc., please refer to the instructions issued with the bulk part.)

Bulk part number of fuel hose, general purpose hose and vinyl hose.

Example: 9 5 0 0 1 - 7 5 0 0 1 - 5 0 M

Bulk part number:

Refers to the bulk part.

Marking code (fuel hose and general purpose hose)

Change code (Vinyl hose)

Indicates number mark or change sequence, however, the code for the bulk part must be strictly 0 (zero).

Types of code:

- | | | | | | |
|-------------|--|----------------|-------------|--------------|---------------|
| • Fuel hose | 2: Red outside braid
(3 mm inside dia. only) | • General hose | 1: Ash gray | • Vinyl hose | 1: Clear |
| | 5: Black inside braid | | 2: Ash gray | | 2: Black |
| | 3: Red (3 mm inside dia. only) | | 3: Black | | 3: Light red |
| | 4: Ash gray with red stripe
(3 mm inside dia. only) | | 5: Black | | 6: Light red |
| | 6: Black | | | | 7: Pale black |

Lengths:

- 001: 1 m (standard)
003: 3 m
008: 8 m } Application or specification of some parts is not settled.

I.D code: (fuel hose and general purpose hose)

- | | | | | |
|------------|--------------------|--------------------|-----------------------------|-----------------------------|
| 30: 3.0 mm | 50: 5.0 mm | 70: 7.0 mm | 11: 11 mm | 12: 12 (outside dia. 17) mm |
| 35: 3.5 mm | 55: 5.3 mm, 5.5 mm | 75: 7.3 mm, 7.5 mm | 91: 12 (outside dia. 15) mm | 14: 14 mm |
| 45: 4.5 mm | 65: 6.5 mm | 80: 8.0 mm | 92: 12 (outside dia. 16) mm | 17: 17 mm |

ID./OD. code: (vinyl hose)

- | | | | | |
|-------------------------|--------------------------|---------------------------|---------------------------|---------------------------|
| 01: ID. 2.9, OD. 6.8 mm | 12: ID. 5.0, OD. 7.0 mm | 21: ID. 8.0, OD. 9.0 mm | 37: ID. 11.0, OD. 15.0 mm | 50: ID. 16.0, OD. 19.0 mm |
| 03: ID. 3.0, OD. 6.0 mm | 10: ID. 5.0, OD. 8.0 mm | 23: ID. 8.0, OD. 12.0 mm | 38: ID. 12.0, OD. 13.0 mm | 55: ID. 17.5, OD. 20.5 mm |
| 05: ID. 3.5, OD. 6.5 mm | 11: ID. 5.0, OD. 9.0 mm | 25: ID. 9.0, OD. 11.0 mm | 39: ID. 12.0, OD. 14.0 mm | 60: ID. 22.0, OD. 27.0 mm |
| 07: ID. 4.0, OD. 7.0 mm | 14: ID. 6.0, OD. 9.0 mm | 27: ID. 9.0, OD. 13.0 mm | 40: ID. 12.0, OD. 16.0 mm | |
| 08: ID. 4.5, OD. 6.5 mm | 17: ID. 7.0, OD. 9.0 mm | 33: ID. 10.0, OD. 14.0 mm | 43: ID. 13.0, OD. 15.0 mm | |
| 09: ID. 4.5, OD. 8.0 mm | 19: ID. 7.0, OD. 11.0 mm | 36: ID. 11.0, OD. 13.0 mm | 45: ID. 14.0, OD. 18.0 mm | |

Hose type:

- 1: Fuel hose
3: Vinyl hose
5: General hose

⊙ **CAUTION: It is DANGEROUS to confuse the fuel hose with the general purpose hose or vinyl hose.**

Never use a general purpose hose or vinyl hose in place of a fuel hose or vice versa. Always use the correct bulk part in the parts catalogue, according to the service manual or the instructions issued with the bulk part.

FLAT RATE SERVICE TIME

Flat rate service time (FRT) means the standard time required to service a product, which is listed in this manual to help the dealers control the actual working process and calculate the service charge by using it as a guide.

FRT setting system

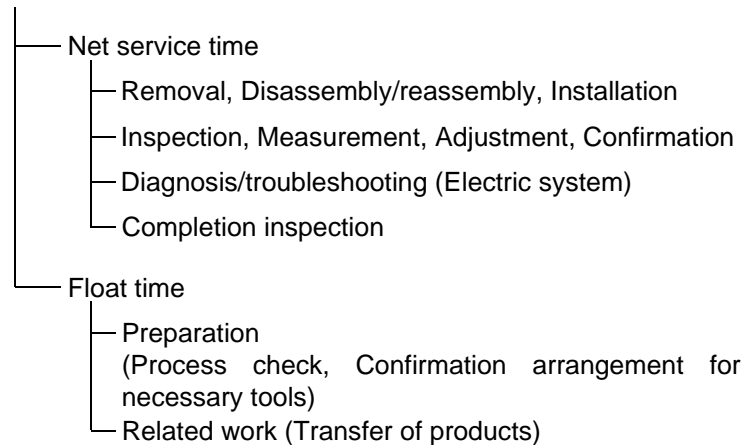

* Float time is set by multiplying the net service time by a given coefficient.

Editorial style

The service items shown in the text are listed with the exchange work time for the repair sales parts as the subject. Other representative service items not using repair parts (removal/installation, adjustment, inspection/measuring, and other work) are listed collectively in the list in the preface, classified according to the work.

FRT setting standard

- Decimal system (in unit of 0.1) is adopted to set FRT as it is convenient to calculate the wage.
Example: (0.1) → 6 minutes, (0.2) → 12 minutes
[Labor cost per hour] x [FRT] = [Wage]
- FRT is set with a hand tool.
- Service items and FRT can be subject to change depending on development of tools and service equipment and improvement in service procedure.

Work procedure

- As the work procedure is set with the work time according to the method in the separate Service Manual, refer to this Manual as required.
- Work methods permitting servicing in the shortest time still permitting assurance of safe work and product warranty are used for the setting of service items not listed in the Service Manual.
- Work basically is to be performed by one person, and when two or more people are required, setting is done as the total time for the number of people.
- The set value for the technological level of the workers uses a person with three years of experience in the repair of Honda products as the standard.
- Special tools and service equipment used to set FRT are those specified or recommended in Service Manual.

Service item whose FRT is not presented

- Accessories and service parts that are not listed to use in this manual.
 - Locations with little aging deterioration or breakage during normal use.
 - Service work that can be finished by one touch.
 - Service work that is seldom done (i.e. extremely small causes of trouble and service frequency).
 - Products and parts whose location for installation differs according to its status of use and application.
- * When FRT is not presented, please calculate wages based on appropriate actual work time.

Operation not included of FRT

- Oil and coolant water draining, Waiting time for warming up operation and etc..
- Additional operation that involves removal/installation of standard exterior equipment.
- Indirect time spent for service by visiting the customer, trade-in, and delivery.
- Indirect time required for ordering and delivery of parts.
- Cost for grease, adhesive agent, etc. used for service work.

Explanation of FRT by using an example
(The example may differ from the actual presented items)

Ref. No.	L.O.N.	(Relative ref. Number) Description	F.R.T.
①	1111L1	(1, 3, 4, 7) VALVE, INTAKE4.1	②
②		• NOTE: OHV type	③
③	1111L1A	• Includes: Engine removal and installation One head (intake all) add1.4	④

- ① Reference No. of the illustration of part that shows location of the replacement work.
- ② FRT is an abbreviation of Flat Rate Time indicating the standard service time required for the replacement.
- ③ LON is an abbreviation of Labor Operation Number, and it is a classification of the service items by the work unit code.

The same operation code is used regardless of the models.

Standard operation is indicated with 6 digits code, and additional operation is indicated with 7 digits code.

- ④ Indicating the intake valve replacement and FRT4.1.
- ⑤ Indicating FRT1.4 that will be added when additional operation (whole intake side of one cylinder head) is done in association with intake valve replacement.

- ⑥ Indicating work condition or application condition of the service item.
- ⑦ Indicating work contents that are included in the service item.
- ⑧ Indicating a reference No. whose operation and time are the same as FRT4.1 for the intake valve.

(The application range is limited to the service items without an LON setting within a same block.)

How to refer to the service item by using the sample
 (intake valve replacement)

Open to the page of the block where the intake valve's spare part illustration is shown.

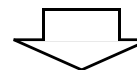

Look for the intake valve illustration, and refer to the service item and FRT that agree with the reference No.

Indication mark for the listing of service items that continues to the following page

Ref. No.	L.O.N.	(Relative ref. Number) Description	F.R.T.
2	1111L1	VALVE, INTAKE	4.1
	.	.	.
	.	.	.

+
Mark indicated at the last line.

Indication of the block with no setting of FRT

Ref. No.	L.O.N.	(Relative ref. Number) Description	F.R.T.
NO INFORMATION			

• LON code system

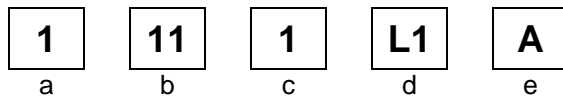

- a) Category code..... Engine
- b) Location/function code..... Engine upper
- c) Operation code..... Replace
- d) Operation sequence number (Unit code can be shown with alphabet)
..... Intake valve
(No regular rule of code)
- e) Additional code One head (intake all)
(No regular rule of code)

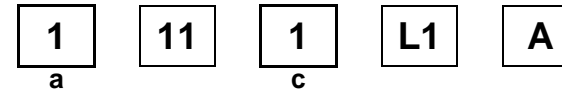

a) Category codes and classification

Code	Category
1	Engine
2	Power drive
3	Fuel & Exhaust
4	Frame & Body
5	Steering
6	Electrical
7	Axle & Brake
8	Control system
9	-
0	Attachments

c) Operation codes and classification

Code	Operation category
1	Replace, Removal/Installation, Change
2	Overhaul
3	Adjust, Rotation
4	(Paint-related work: Top-coat)
5	Test, Inspect/diagnose, Measurement
6	(Overhaul-related work: Rebore)
7	(Overhaul-related work: Reseal)
8	(Resurface)
9	(Paint-related work: Refinish)
0	Repair, Cleaning, Air bleeding

Major service items without using spare parts
Removal/Installation, Adjustment, Inspection/Masurement, Overhaul, Other work

E: Engine, T: Transmission, D: Drive system, B: Body and related parts

• Removal/Installation

Set with the parts configuration in the status of being removed from the product.

	LON	DESCRIPTION	FRT
E	1001A2	ENGINE-REMOVAL/INSTALLATION	1.0
D	2101S4	GEAR CASE-REMOVAL/INSTALLATION	0.4

• Adjustment

	LON	DESCRIPTION	FRT
E	1113A1	VALVE CLEARANCE-ADJUSTMENT NOTE: For 1 product	0.8
	3113A2	CARBURETOR IDLE-ADJUSTMENT	0.2
	8113B1	THROTTLE CABLE-ADJUSTMENT	0.2

• Inspection/Masurement

	LON	DESCRIPTION	FRT
E	1105A0	ENGINE OIL-INSPECTION	0.1

• Overhaul

Work condition: The required Measurements, inspections, adjustments, and cleaning/washing of each part are performed, including the main body removal/installation work and the replacement of defective parts.

	LON	DESCRIPTION	FRT
E	3112A0	CARBURETOR-OVERHAUL INCLUDES: All necessary adjustment	0.6

• Other work

	LON	DESCRIPTION	FRT
E	1101E1	ENGINE OIL-CHANGE INCLUDES: Engine oil-inspection	0.2
	6140A0	SPARK PLUG-ADJUSTMENT/CLEANING INCLUDES: Spark plug check NOTE: For 1 product	0.1

ENGINE GROUP

E-3

CYLINDER BARREL

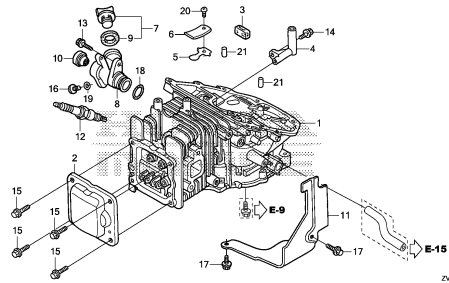

ZVA3E0300

E-5

OIL CASE

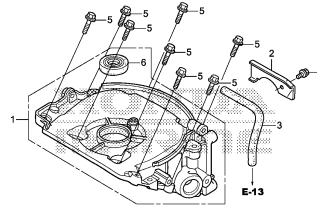

ZVA3E0500

E-6

CRANKCASE SIDE COVER

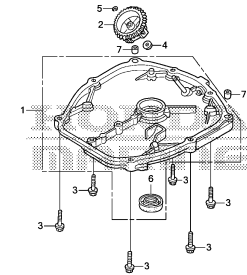

ZVA3E0600

E-7

CRANKSHAFT

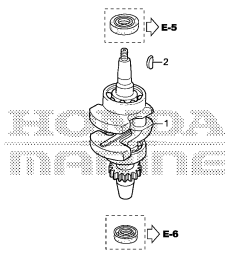

ZVA3E0700

E-8

PISTON/CONNECTING ROD

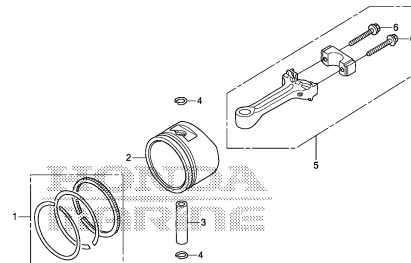

ZVA3E0800

E-9

CAMSHAFT

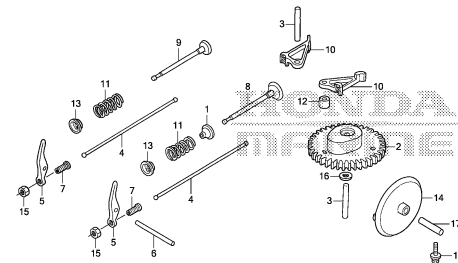

ZVA3E0900

E-11

RECOIL STARTER

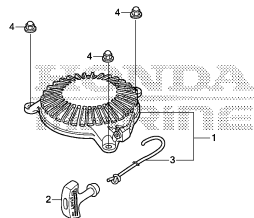

ZVA3E1100

E-12

FAN COVER

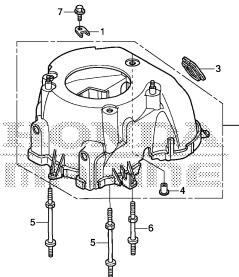

ZVA3E1200

E-13

CLUTCH

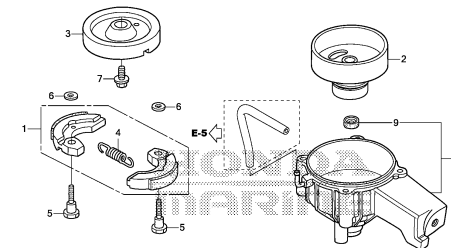

ZVA3E1300

ENGINE GROUP

E-14

CARBURETOR

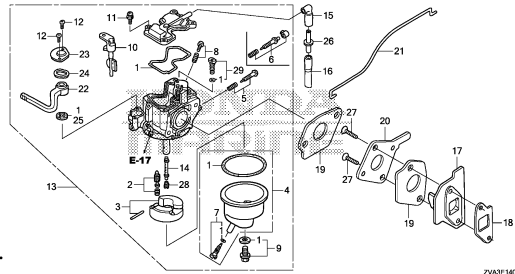

ZVA3E1400

E-15

AIR GUIDE

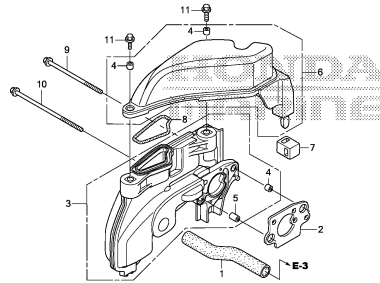

ZVA3E1500

E-16

EXHAUST PIPE

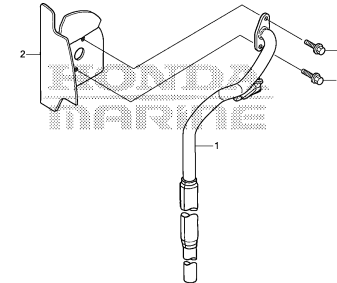

ZVA3E1600

E-17

FUEL TANK

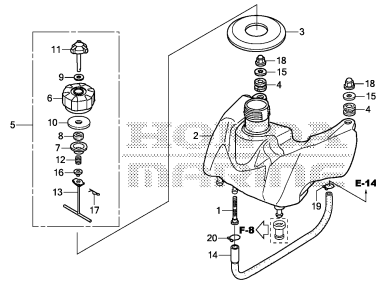

ZVA3E1700

E-19

FLYWHEEL

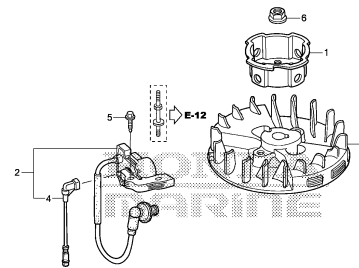

ZVA3E1900

2

FRAME GROUP

F-1

STEERING HANDLE

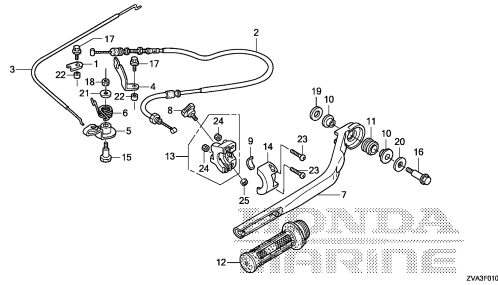

ZVA3F1000

F-3

EXTENSION CASE

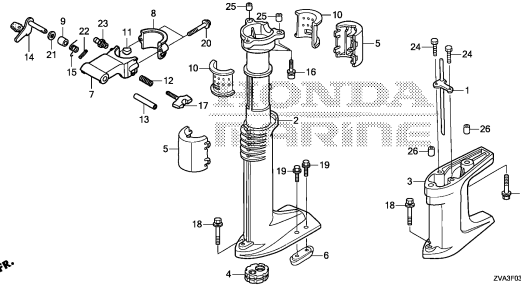

ZVA3F0300

F-5

GEAR CASE/PROPELLER

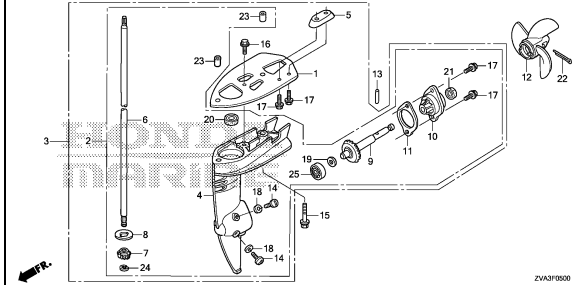

ZVA3F0500

F-8

ENGINE COVER

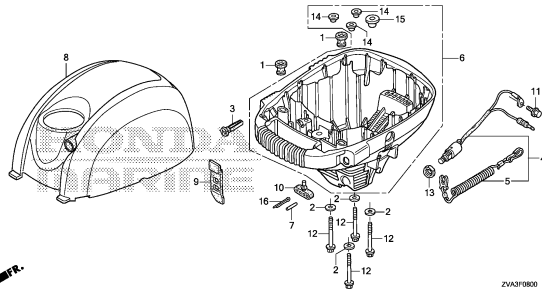

ZVA3F0800

F-10

STERN BRACKET

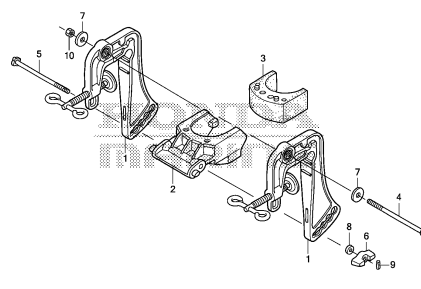

ZVA3F1000

F-12

LABEL

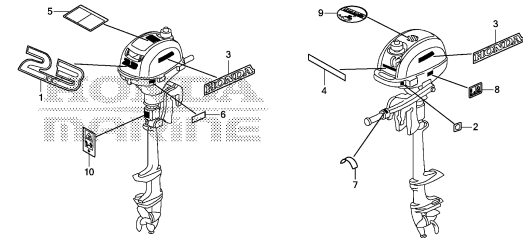

ZVA3F1200

F-13

TOOL

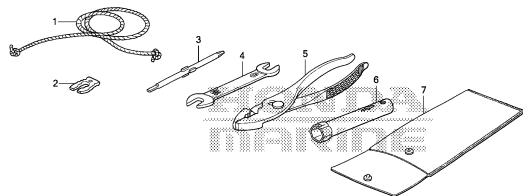

ZVA3F1300

E-3

CYLINDER BARREL

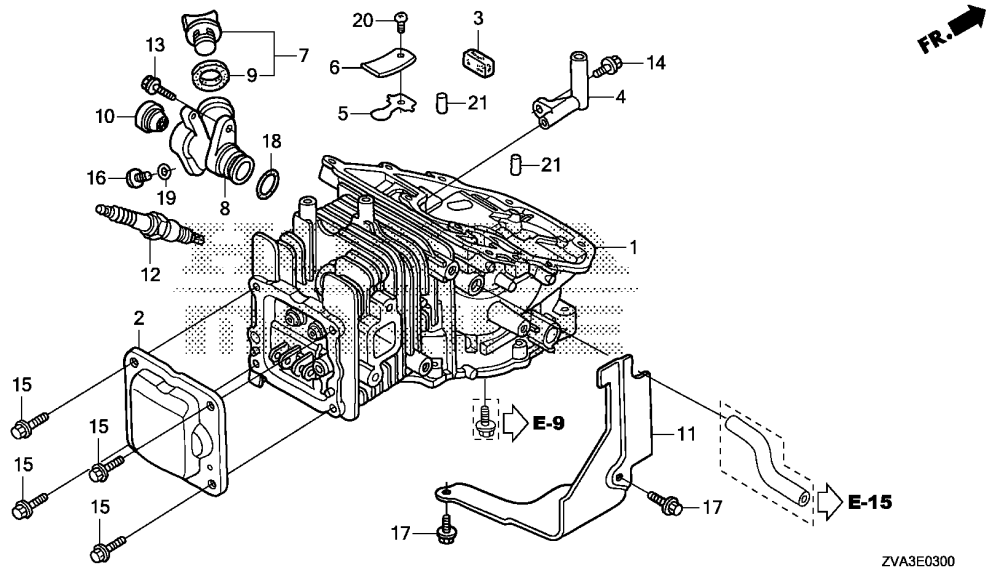

Ref. No.	L.O.N.	(Relative ref. Number) Description	F.R.T.
1	1101A0	BARREL, CYLINDERINCLUDES: Engine removal and installation	2.2
2	1111D5	CYLINDER HEAD COVER AND/OR PACKING	0.7
3	1111E5	FILTER, BREATHER	0.9
5		(6)	
8	1171A8	VALVE, OIL OUTLET	0.9
		(18)	
	1101P5	EXTENSION, OIL LEVEL FINDER ..	0.6
11	4141E6	SHROUD, CYLINDER HEAD	0.7
12	6141C1	PLUG, SPARK	0.1
		.INCLUDES: Spark plug check	

Ref. No.	Part No.	Description	Reqd. QTY		Serial No.	Parts catalogue code
			BF	2.3DH		
			(1)	(2)		
1	12100-ZW6-T00	BARREL COMP., CYLINDER	1	1		
2	12311-ZVA-000ZA	COVER, HEAD *NH105*...MAT BLACK (#15-#20)	1	1		
3	12367-ZE6-020	FILTER, BREATHER	1	1		
4	15171-ZN4-000	PIPE, BREATHER	1	1		
5	15571-ZM7-003	VALVE, OIL OUTLET	1	1		
6	15572-ZM7-000	PLATE, STOPPER	1	1		
7	15600-Z1T-600	CAP ASSY., OIL FILLER	1	1		
8	15622-ZVA-000	EXTENSION, OIL LEVEL FINDER ..	1	1		
9	15625-Z1T-000	PACKING, OIL FILLER CAP	1	1		
10	15661-ZV0-003	FINDER, OIL LEVEL	1	1		
11	19631-ZVA-000	SHROUD	1	1		
12	31914-Z8Y-003	PLUG, SPARK(LR4C-E)(NGK)	1	1		
13	90003-ZVA-000	BOLT, FLANGE, 5X16	1	1		
14	90008-ZM7-000	BOLT, 4X10	1	1		
15	90009-ZVA-000	BOLT, FLANGE, 5X12(SUS)	4	4		
16	90017-ZVA-000	BOLT, OIL CHECK	1	1		
17	90019-ZV1-010	BOLT, FLANGE, 5X10	2	2		
18	91301-ZE9-003	O-RING, 22.1X2.2	1	1		
19	91325-P4V-003	O-RING, 6.9X1.5	1	1		
20	93500-03005-0A	SCREW, PAN, 3X5	1	1		
21	96220-60150	ROLLER, 6X15	2	2		

2

E-5

OIL CASE

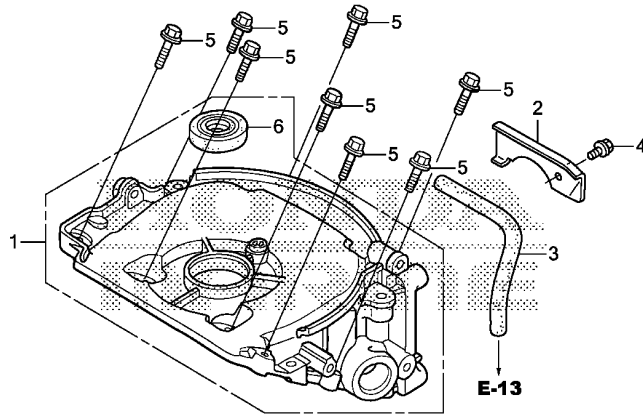

ZVA3E0500

Ref. No.	L.O.N.	(Relative ref. Number) Description	F.R.T.
1	110120	CASE, OIL SEALINCLUDES: Engine removal and installation	1.4
3	2121G0	TUBE, CLUTCH HOUSING BREATHER	0.3
6	1101E6	OIL SEAL, CRANKSHAFT :UPPER .. .INCLUDES: Engine removal and installation	1.4

Ref. No.	Part No.	Description	Reqd. QTY		Serial No.	Parts catalogue code
			BF 2.3DH (1)	(2)		
1	11300-ZW6-T00	CASE ASSY., OIL	1	1		
2	11316-ZVA-000	PLATE, TUBE SETTING	1	1		
3	15723-ZVA-000	TUBE, CLUTCH HOUSING BREATHER	1	1		
4	90019-ZV1-010	BOLT, FLANGE, 5X10	1	1		
5	90174-ZW4-000	BOLT, FLANGE, 5X23(CT200) ...	8	8		
6	91202-HC5-003	OIL SEAL, 17X27X5 (ARAI)	1	1		



E-6

CRANKCASE SIDE COVER

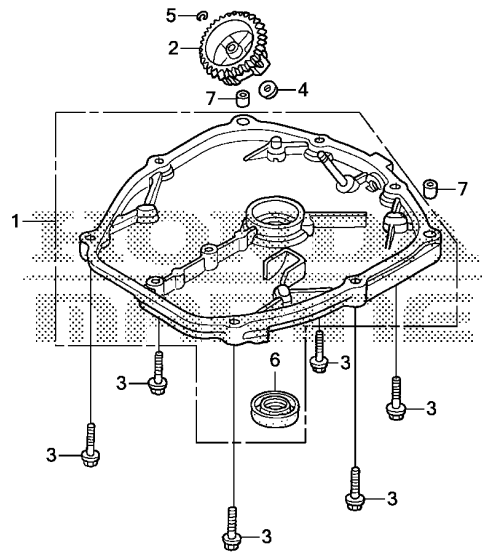

ZVA3E0600

Ref. No.	L.O.N.	(Relative ref. Number) Description	F.R.T.
1	1101B3	COVER, CRANKCASE SIDEINCLUDES: Engine removal and installation	1.3
2	1161A7	HOLDER, GOVERNOR WEIGHTINCLUDES: Engine removal and installation	1.2
6	1101E7	OIL SEAL, CRANKSHAFT :LOWER .. .INCLUDES: Engine removal and installation	1.2

Ref. No.	Part No.	Description	Reqd. QTY		Serial No.	Parts catalogue code
			BF	(2)		
1	11340-ZW6-T00	COVER COMP., CRANKCASE SIDE .	1	1		
2	16512-ZM7-D00	HOLDER, GOVERNOR WEIGHT	1	1		
3	90174-ZW4-000	BOLT, FLANGE, 5X23(CT200) ...	6	6		
4	90441-ZM7-000	WASHER, 4.2X13	1	1		
5	90602-ZM7-000	CLIP, GOVERNOR HOLDER	1	1		
6	91202-HC5-003	OIL SEAL, 17X27X5 (ARAI)	1	1		
7	94301-06100	DOWEL PIN, 6X10	2	2		

2

E-7

CRANKSHAFT

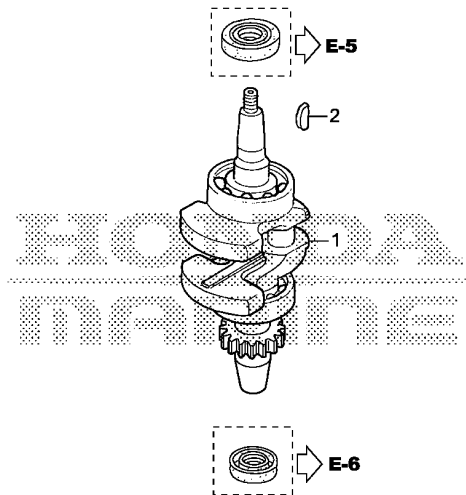

FR. →

ZVA3E0700

Ref. No.	L.O.N.	(Relative ref. Number) Description	F.R.T.
1	1101F0	CRANKSHAFT INCLUDES: Engine removal and installation	1.8

Ref. No.	Part No.	Description	Reqd. QTY		Serial No.	Parts catalogue code
			BF	2.3DH		
			(1)	(2)		
1	13310-ZN4-020	CRANKSHAFT COMP.	1	1		
2	13331-ZVA-000	KEY, SPECIAL	1	1		

2

E-8

PISTON/CONNECTING ROD

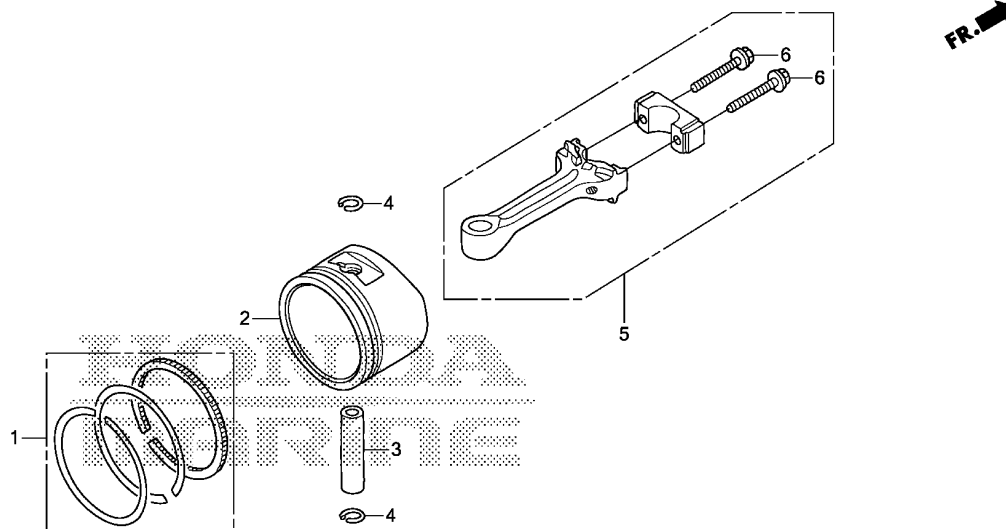

ZVA3E0800

Ref. No.	L.O.N.	(Relative ref. Number) Description	F.R.T.
2		(1,3,5)	
1111R1		PISTON AND/OR RING SET AND/OR BEARING AND/OR RODINCLUDES: Engine removal and installation .INCLUDES: Inspection/Measurement/Cleaning	1.9

Ref. No.	Part No.	Description	Reqd. QTY		Serial No.	Parts catalogue code
			BF	2.3DH		
			(1)	(2)		
1	13010-ZW6-000	RING SET, PISTON(STD.)	1	1		
2	13101-ZW6-010	PISTON(STD.)	1	1		
3	13111-ZVA-000	PIN, PISTON	1	1		
4	13115-ZVA-000	CLIP, PISTON PIN, 10MM	2	2		
5	13200-ZN4-010	ROD ASSY., CONNECTING	1	1		
6	90001-ZM7-000	BOLT, CONNECTING ROD	2	2		

2

E-9

CAMSHAFT

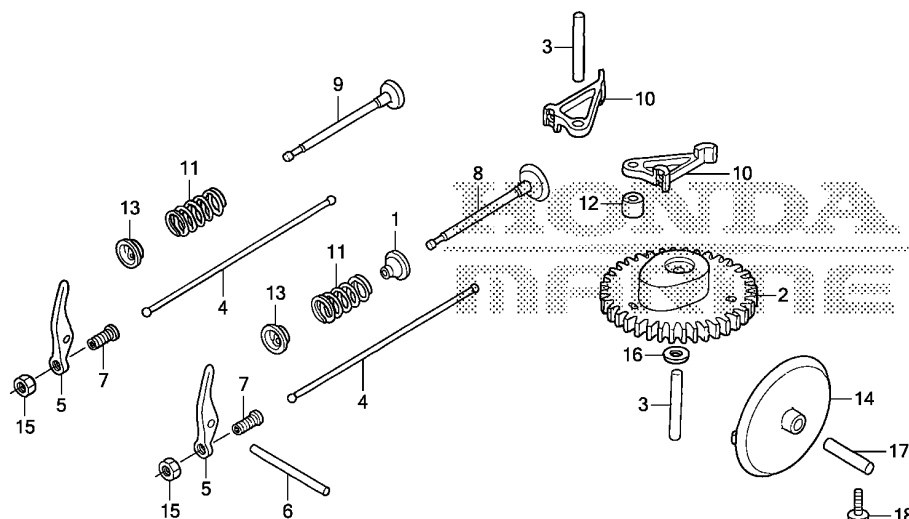

ZVA3E0900

Ref. No.	L.O.N.	(Relative ref. Number) Description	F.R.T.
1	1111K2	SEAL, INTAKE VALVE STEMINCLUDES: Engine removal and installation .INCLUDES: Valve clearance adjustment	2.0
2	1111C2	CAMSHAFTINCLUDES: Engine removal and installation .INCLUDES: Valve clearance adjustment	1.1
4	1111L6	ROD, PUSH :INTAKEINCLUDES: Valve clearance adjustment	1.1
	1111L6A	.Replace exhaust push rod add	0.1
	1111L7	ROD, PUSH :EXHAUSTINCLUDES: Valve clearance adjustment	1.1
	1111L7A	.Replace intake push rod add	0.1
5	1111A2	ARM, ROCKER :INTAKEINCLUDES: Valve clearance adjustment	1.0
	1111A2A	.Replace exhaust rocker arm add	0.1
+	1111A1	ARM, ROCKER :EXHAUSTINCLUDES: Valve clearance adjustment	1.0

Ref. No.	Part No.	Description	Reqd. QTY		Serial No.	Parts catalogue code
			BF	2.3DH		
			(1)	(2)		
1	12209-ZM7-003	SEAL, VALVE STEM	1	1		
2	14111-ZVA-000	CAMSHAFT	1	1		
3	14126-Z0G-003	ROLLER(5X29.8)	2	2		
4	14410-ZVA-000	ROD, PUSH	2	2		
5	14431-ZVA-000	ARM, VALVE ROCKER	2	2		
6	14435-ZM7-003	ROLLER(4X37.8)	1	1		
7	14451-ZM7-000	PIVOT, ROCKER ARM	2	2		
8	14711-ZW6-000	VALVE, IN.	1	1		
9	14721-ZW6-000	VALVE, EX.	1	1		
10	14731-ZM7-013	LIFTER, VALVE	2	2		
11	14751-ZM7-000	SPRING, VALVE	2	2		
12	14754-ZVA-000	COLLAR, LIFTER	1	1		
13	14771-ZM3-010	RETAINER, VALVE SPRING	2	2		
14	15361-ZN4-000	SLINGER, OIL	1	1		
15	90206-ZVA-000	NUT, TAPPET ADJUSTING	2	2		
16	90401-ZVA-000	WASHER, 6MM	1	1		
17	91151-VB5-800	ROLLER, 6X25	1	1		
18	93404-05016-08	BOLT-WASHER, 5X16	1	1		



E-9

CAMSHAFT

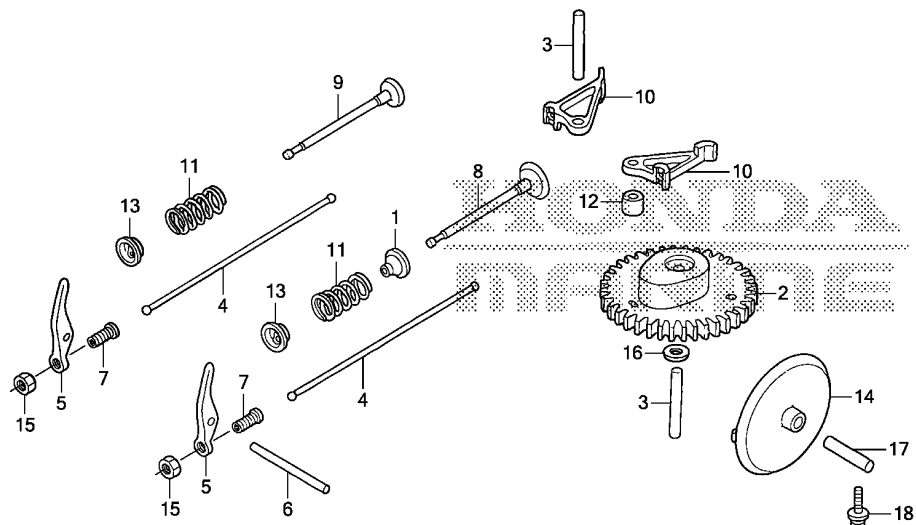

FR. →

ZVA3E0900

Ref. No.	L.O.N.	(Relative ref. Number) Description	F.R.T.
+ 5		.INCLUDES: Valve clearance adjustment	
8	1111A1A	.Replace intake rocker arm add	0.1
	1111L1	VALVE, INTAKE	2.0
		.INCLUDES: Engine removal and installation	
		.INCLUDES: Valve clearance adjustment	
	1111L1E	.Replace intake and exhaust all add	0.1
9	1111L0	VALVE, EXHAUST	2.0
		.INCLUDES: Engine removal and installation	
		.INCLUDES: Valve clearance adjustment	
	1111L0E	.Replace intake and exhaust all add	0.1
10	1111L9	LIFTER, VALVE :INTAKE	1.1
		.INCLUDES: Engine removal and installation	
	1111M0	LIFTER, VALVE :EXHAUST	1.1
		.INCLUDES: Engine removal and installation	
+11	1111P3	SPRING, VALVE :INTAKE	1.9

2

E-9

CAMSHAFT

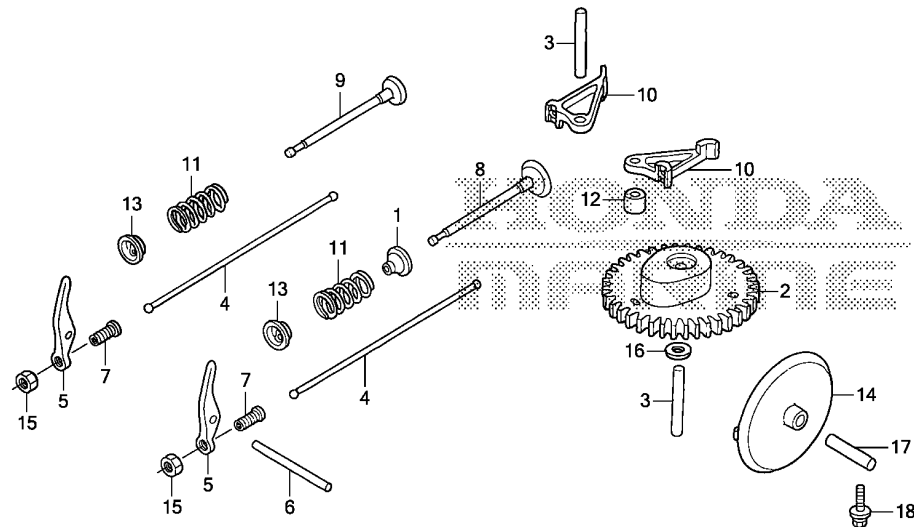

FR. →

ZVA3E0900

Ref. No.	L.O.N.	(Relative ref. Number) Description	F.R.T.
+11		.INCLUDES: Engine removal and installation .INCLUDES: Valve clearance adjustment	
1111P3A		.Replace intake and exhaust all add	0.1
1111P4		SPRING, VALVE :EXHAUST	1.9
		.INCLUDES: Engine removal and installation .INCLUDES: Valve clearance adjustment	
1111P4A		.Replace intake and exhaust all add	0.1
14 1101K6		GEAR, OIL SLINGER DRIVEN	1.1
		.INCLUDES: Engine removal and installation	



E-11

RECOIL STARTER

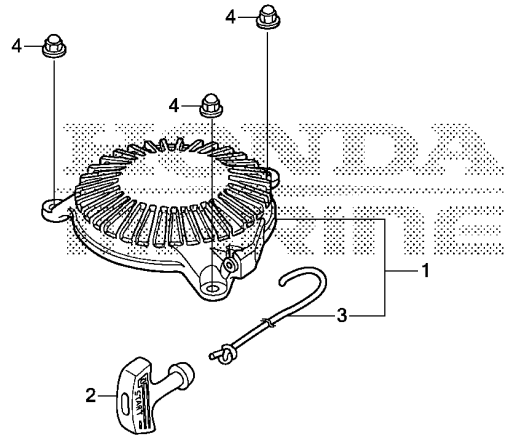

FR.

ZVA3E1100

Ref. No.	L.O.N.	(Relative ref. Number) Description	F.R.T.
1	1121B9	STARTER, RECOIL	0.2
2	1121A3	GRIP, RECOIL STARTER	0.1
3	1121B3	ROPE, RECOIL STARTER	0.3

Ref. No.	Part No.	Description	Reqd. QTY		Serial No.	Parts catalogue code
			BF 2.3DH (1)	(2)		
1	28400-ZVA-003	STARTER ASSY., RECOIL	1	1		
2	28461-ZVA-003	KNOB, STARTER	1	1		
3	28462-ZW6-003	ROPE, RECOIL STARTER	1	1		
4	90202-ZVA-000	NUT, FLANGE CAP, 5MM	3	3		

2

E-12

FAN COVER

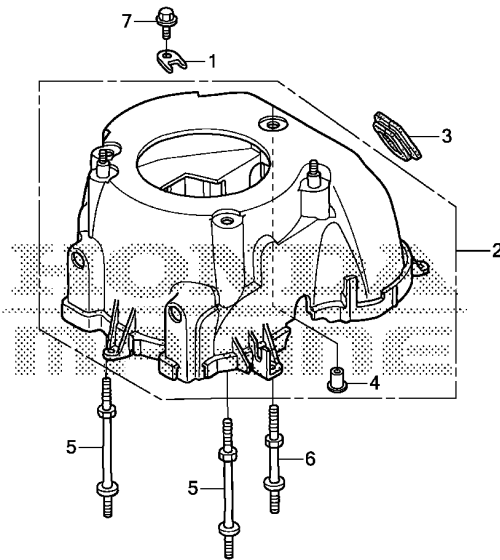

Ref. No.	L.O.N.	(Relative ref. Number) Description	F.R.T.
2	1141G8	COVER, ENGINE COOLING FAN	0.3
3	4131V6	GROMMET, FAN COVER	0.1

Ref. No.	Part No.	Description	Reqd. QTY		Serial No.	Parts catalogue code
			BF	2.3DH		
			(1)	(2)		
1	16576-ZVA-000	HOLDER, CABLE	1	1		
2	19610-ZVA-000	COVER COMP., FAN	1	1		
3	19618-ZVA-000	GROMMET, FAN COVER	1	1		
4	19619-ZVA-300	COLLAR, FAN COVER	3	3		
5	90042-ZM7-000	BOLT A, STUD	2	2		
6	90043-ZM7-000	BOLT B, STUD	1	1		
7	90058-ZVA-000	BOLT, FLANGE, 5X10	1	1		



E-13

CLUTCH

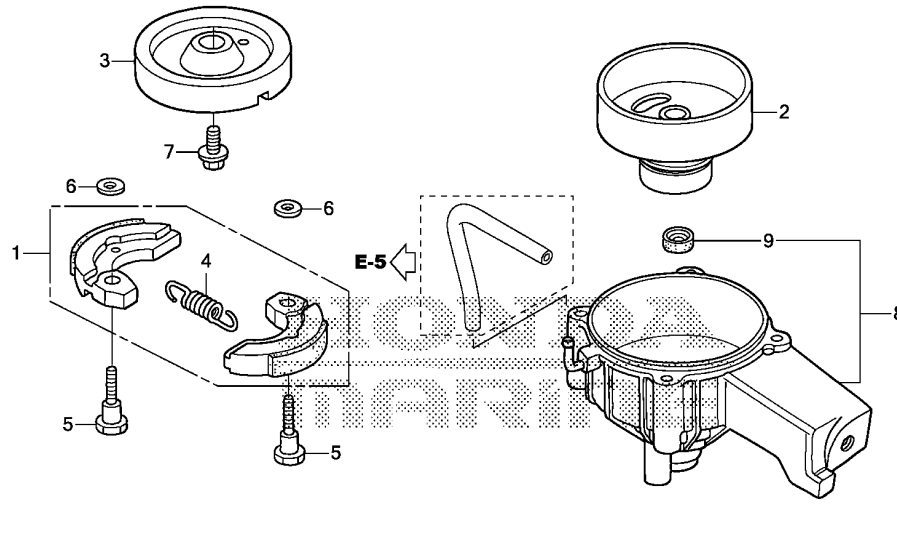

Ref. No.	L.O.N.	(Relative ref. Number) Description	F.R.T.
1	2121F7	CLUTCH, CENTRIFUGALINCLUDES: Engine removal and installation	0.8
2	2121C0	OUTER, CLUTCHINCLUDES: Engine removal and installation	1.1
3	2121F9	STAY, CENTRIFUGAL CLUTCHINCLUDES: Engine removal and installation	0.8
8	2121B6	HOUSING, CLUTCHINCLUDES: Engine removal and installation	1.2
9	2121F8	WATER SEAL, CLUTCH HOUSINGINCLUDES: Engine removal and installation	1.2

Ref. No.	Part No.	Description	Reqd. QTY		Serial No.	Parts catalogue code
			BF	(2)		
1	22000-ZW6-701	CLUTCH ASSY.	1	1		
2	22100-ZW6-704	OUTER ASSY., CLUTCH	1	1		
3	22214-ZW6-703	STAY, CLUTCH	1	1		
4	22252-ZW6-701	SPRING, CLUTCH SHOE	1	1		
5	22253-ZW6-700	BOLT, CLUTCH(8MM)	2	2		
6	22254-ZW6-700	WASHER, PLAIN(8MM)	2	2		
7	22255-ZVA-000	BOLT, CLUTCH STAY(8MM)	1	1		
8	22260-ZVA-000	HOUSING ASSY., CLUTCH	1	1		
9	91251-ZW6-013	SEAL, WATER, 11X21X8	1	1		

2

E-14

CARBURETOR

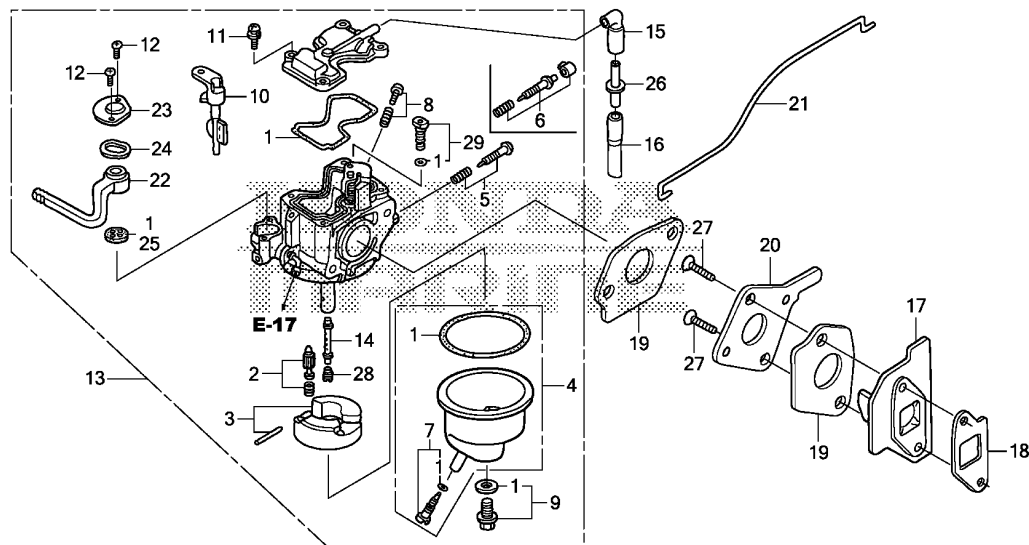

ZVA3E1400

Ref. No.	L.O.N.	(Relative ref. Number) Description	F.R.T.
1	3111B1	GASKET SET, CARBURETOR (3)	0.3
2	3111E1	FLOAT VALVE SET AND/OR FLOAT SET	0.3
4	3111A3	FLOAT CHAMBER SET AND/OR GASKET (6)	0.2
5	3111D7	SCREW SET, PILOT	0.2
10	8101F9	LEVER, CARBURETOR CHOKE	0.2
13	3111F3	CARBURETOR (18)	0.2
17	3111C0	CARBURETOR INSULATOR AND/OR PACKING	0.2
19	3111C8	PACKING, CARBURETOR	0.2
21	8101J8	ROD, CARBURETOR CHOKE	0.1
22	3101E6	LEVER, FUEL COCK (23,24)	0.2
25	3101C5	PACKING, FUEL COCK (14)	0.2
28	3111C3	JET, MAIN	0.3

Ref. No.	Part No.	Description	Reqd. QTY		Serial No.	Parts catalogue code
			BF	2.3DH		
			(1)	(2)		
1	16010-ZW6-611	GASKET SET	1	1		
2	16011-ZE0-005	VALVE SET, FLOAT	1	1		
3	16013-ZG0-811	FLOAT SET	1	1		
4	16015-ZW6-G01	CHAMBER SET, FLOAT	1	1		
5	16016-ZW6-003	SCREW SET	1	1	-----	LCHD,SCHD,SCHH
6	16016-ZW6-E11	SCREW SET	1	-	-----	LCHU,SCHU
7	16024-ZW6-003	SCREW SET, DRAIN	1	1		
8	16028-ZW6-003	SCREW SET	1	1		
9	16028-ZW6-611	SCREW SET	1	1		
10	16044-ZV0-A01	LEVER SET, CHOKE	1	1		
11	16081-ZV1-A00	SCREW, PAN	4	4		
12	16082-ZW6-003	SCREW, PAN, 3X6	2	2		
13	16100-ZVA-003	CARBURETOR ASSY. (BF33T A)	1	1	-----	LCHD,SCHD,SCHH
	16100-ZVA-E01	CARBURETOR ASSY. (BF33V A)	1	-	-----	LCHU,SCHU
14	16166-ZW6-G01	NOZZLE, MAIN	1	1		
15	16196-ZVA-000	TUBE A, AIR VENT	1	1		
16	16197-ZVA-000	TUBE B, AIR VENT	1	1		
17	16211-ZVA-000	INSULATOR, CARBURETOR	1	1		
18	16212-ZVA-000	PACKING, INSULATOR	1	1		
19	16221-ZVA-000	PACKING, CARBURETOR	2	2		
20	16225-ZVA-000	PLATE, CARBURETOR JOINT	1	1		
21	16674-ZVA-000	ROD, CHOKE	1	1		
22	16953-ZW6-003	LEVER, COCK	1	1		
23	16954-ZW6-003	PLATE, LEVER SETTING	1	1		
24	16956-ZE1-811	SPRING, COCK LEVER	1	1		



E-14

CARBURETOR

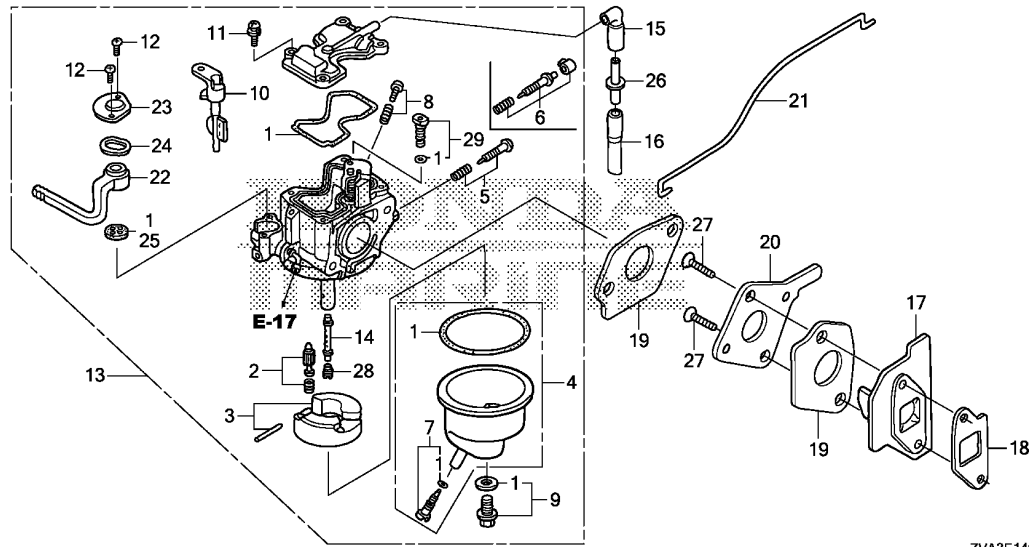

Ref. No.	Part No.	Description	Reqd. QTY		Serial No.	Parts catalogue code
			BF	2.3DH		
			(1)	(2)		
25	16957-ZE1-812	PACKING, FUEL COCK	1	1		
26	16958-ZVA-000	JOINT, AIR VENT TUBE	1	1		
27	90012-ZVA-000	SCREW, FLAT, 5X20	2	2		
28	99101-ZG0-0580	JET, MAIN, #58	(1)	(1)		
	99101-ZG0-0600	JET, MAIN, #60	(1)	(1)		
	99101-ZG0-0620	JET, MAIN, #62	1	1		
29	99204-ZE0-0350	JET SET, PILOT, #35	1	1		

E-15

AIR GUIDE

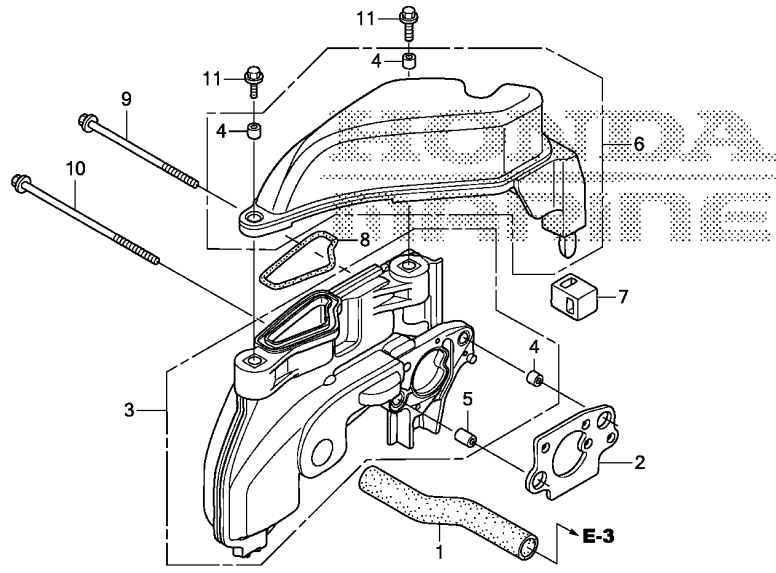

Ref. No.	L.O.N.	(Relative ref. Number) Description	F.R.T.
1	1111K5	TUBE, BREATHER	0.3
2	3121N5	PACKING, AIR INTAKE GUIDE	0.2
3	3121C7	GUIDE, AIR INTAKE	0.2

←FR.

ZVA3E1500

Ref. No.	Part No.	Description	Reqd. QTY		Serial No.	Parts catalogue code
			BF 2.3DH (1)	(2)		
1	15721-ZVA-000	TUBE, BREATHER	1	1		
2	16202-ZVA-000	PACKING, AIR GUIDE	1	1		
3	17201-ZVA-000	GUIDE, AIR INLET	1	1		
4	17202-ZVA-300	COLLAR, DISTANCE	3	3		
5	17204-ZVA-300	COLLAR, DISTANCE(14MM)	1	1		
6	17371-ZVA-000	CASE COMP., SILENCER	1	1		
7	17374-ZVA-000	GROMMET, SILENCER	1	1		
8	17375-ZVA-000	SEAL, SILENCER	1	1		
9	90002-ZVA-000	BOLT, FLANGE, 5X62	1	1		
10	90005-ZVA-000	BOLT, FLANGE, 5X70	1	1		
11	90049-ZVA-000	BOLT, FLANGE, 5X12	2	2		



E-16

EXHAUST PIPE

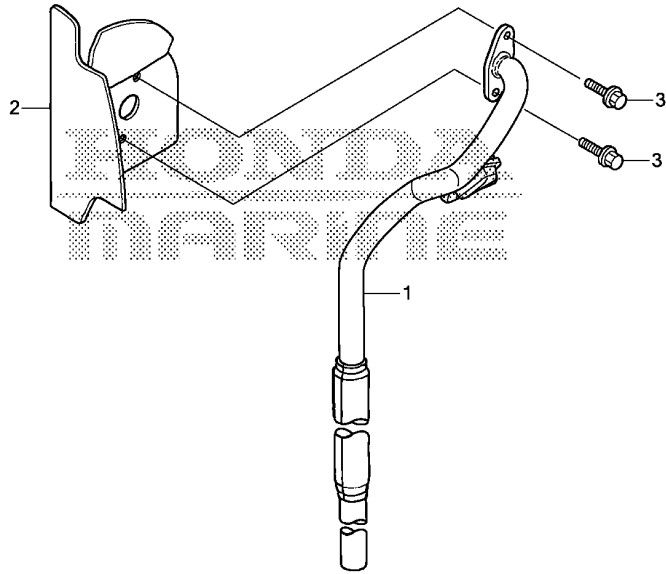

ZVA3E1600

Ref. No.	L.O.N.	(Relative ref. Number) Description	F.R.T.
1	3131C9	PIPE, EXHAUSTINCLUDES: Engine removal and installation	1.1
2	3131B6	GUIDE, AIR EXHAUST	0.4

Ref. No.	Part No.	Description	Reqd. QTY		Serial No.	Parts catalogue code
			BF 2.3DH (1)	(2)		
1	18330-ZVA-000	PIPE COMP., EX.	1	1		
2	18515-ZVA-000	GUIDE, AIR EX.	1	1		
3	90007-ZVA-000	BOLT, FLANGE, 5X16(SUS)	2	2		

2

E-17

FUEL TANK

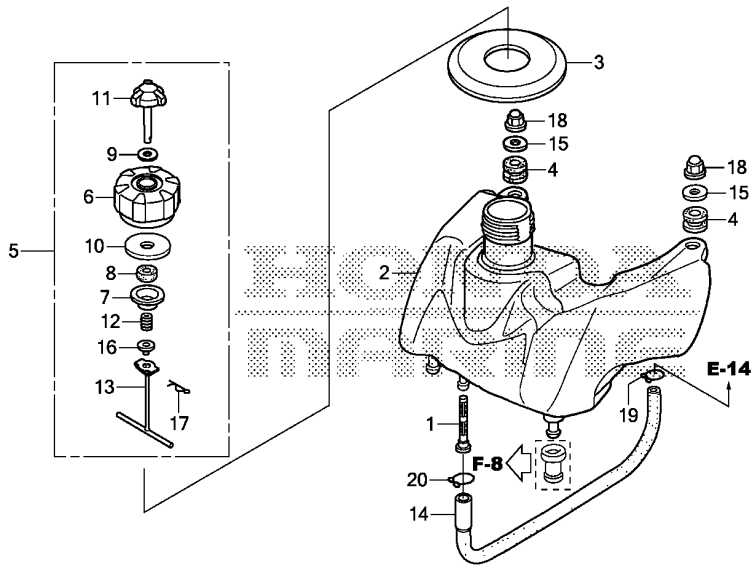

Ref. No.	L.O.N.	(Relative ref. Number) Description	F.R.T.
1	3101H8	STRAINER, FUEL	0.2
2	3101H7	TANK, FUEL	0.3
3	3101M3	RUBBER A, TANK MOUNTING	0.1
5	3101M7	CAP, FUEL FILLER	0.1
10	3101L9	PACKING, FUEL CAP	0.1
11		(9)	
	3101Q9	VALVE, FUEL BREATHER	0.1
13	3101Q8	LINK, FUEL CAP	0.1
14	3101F1	TUBE, FUEL TANK	0.2

FR.

ZVA3E1700

Ref. No.	Part No.	Description	Reqd. QTY		Serial No.	Parts catalogue code
			BF	2.3DH		
			(1)	(2)		
1	16952-ZVA-000	STRAINER, FUEL	1	1		
2	17511-ZVA-000	TANK, FUEL	1	1		
3	17515-ZVA-E10	RUBBER, TANK CAP	1	1		
4	17531-ZVA-000	GROMMET, FUEL TANK	2	2		
5	17620-ZVA-000	CAP ASSY., FUEL TANK	1	1		
6	17621-ZVA-000	BODY, FUEL CAP	1	1		
7	17622-ZVA-000	INNER, FUEL CAP	1	1		
8	17623-ZV0-000	SPONGE, FUEL CAP BREATHER ...	1	1		
9	17624-ZVA-000	PACKING, BREATHER VALVE	1	1		
10	17625-ZVA-000	PACKING, FUEL CAP	1	1		
11	17626-ZVA-000	VALVE COMP., BREATHER	1	1		
12	17629-ZVA-000	SPRING, FUEL CAP	1	1		
13	17633-ZVA-000	TETHER, FUEL CAP	1	1		
14	17701-ZVA-000	TUBE, FUEL	1	1		
15	90403-ZVA-000	WASHER, PLAIN, 6MM	2	2		
16	90404-ZVA-000	COLLAR, 6.5X7.5	1	1		
17	90701-ZVA-000	PIN, LOCK, 4MM	1	1		
18	94021-06020-0S	NUT, CAP, 6MM	2	2		
19	95002-02109	CLIP, TUBE(B10)	1	1		
20	95002-02129	CLIP, TUBE(B12)	1	1		

2

E-19

FLYWHEEL

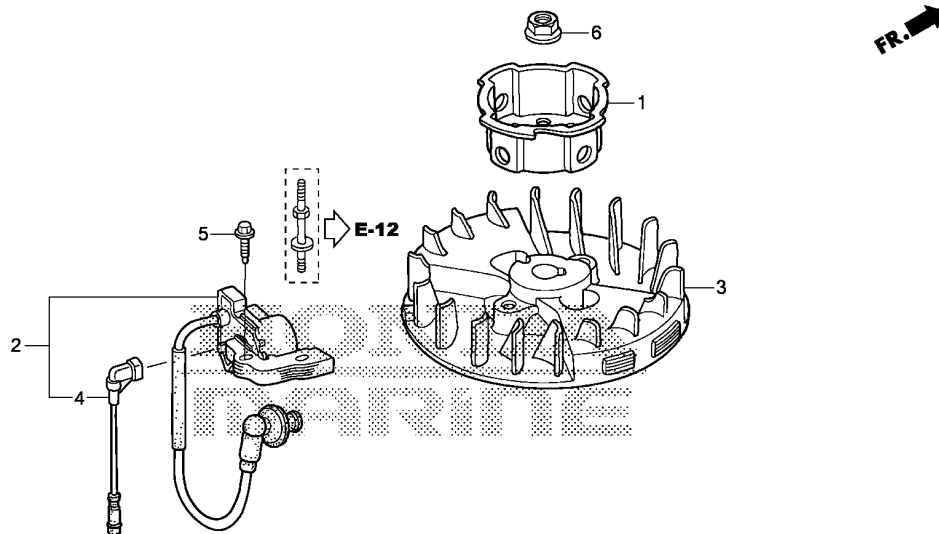

Ref. No.	L.O.N.	(Relative ref. Number) Description	F.R.T.
1	1121A9	PULLEY, RECOIL STARTER	0.3
2	6141A5	COIL, IGNITION(ONE)	0.4
3	2161B5	FLYWHEEL	0.4
4	6111B3	CORD, STOP SWITCH	0.3

Ref. No.	Part No.	Description	Reqd. QTY		Serial No.	Parts catalogue code
			BF	2.3DH		
			(1)	(2)		
1	28451-ZVA-003	PULLEY, STARTER	1	1		
2	30500-ZVA-003	COIL ASSY., IGNITION	1	1		
3	31110-ZVA-003	FLYWHEEL COMP.	1	1		
4	32195-ZVA-003	CORD, STOP SWITCH	1	1		
5	90004-ZW4-000	BOLT, FLANGE, 5X20(CT200) ...	1	1		
6	90203-ZVA-000	NUT, FLANGE, 10MM	1	1		

2

F-1

STEERING HANDLE

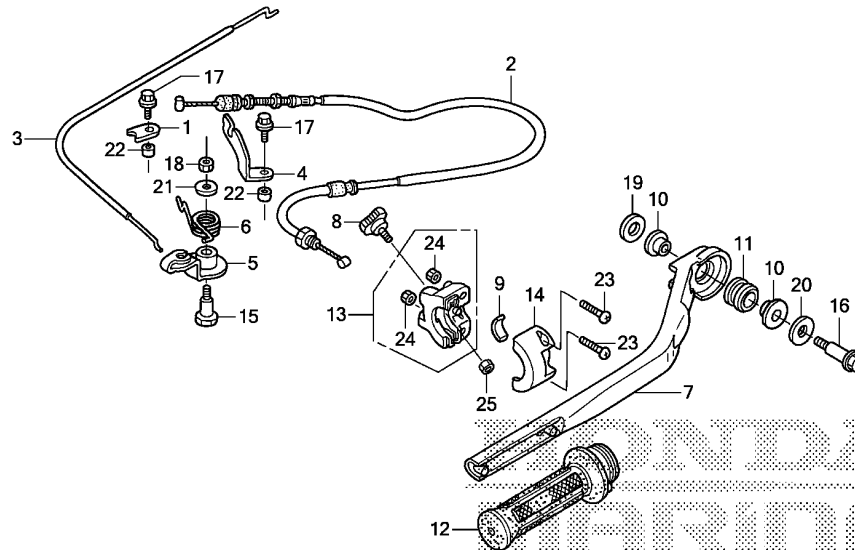

ZVA3F0100

Ref. No.	L.O.N.	(Relative ref. Number) Description	F.R.T.
2	8111E8	CABLE A, THROTTLE	0.3
3	8111E9	CABLE B, THROTTLE	0.2
5	8101A7	ARM, THROTTLE	0.2
6	8101Z5	SPRING, THROTTLE ARM	0.1
7	8101E4	HANDLE, STEERING	0.2
9	8101U0	BLOCK, THROTTLE FRICTION	0.1
11		(10,20)	
	5101E4	RUBBER, HANDLE MOUNTING	0.1
12	8101DN	GRIP, THROTTLE	0.1
13	4131V7	HOUSING, THROTTLE :UNDER	0.1
14	4131K9	HOUSING, THROTTLE :UPPER	0.1

Ref. No.	Part No.	Description	Reqd. QTY		Serial No.	Parts catalogue code
			BF	2.3DH		
			(1)	(2)		
1	16576-ZVA-000	HOLDER, CABLE	1	1		
2	17910-ZVA-003	CABLE COMP. A, THROTTLE	1	1		
3	17920-ZVA-000	CABLE COMP. B, THROTTLE	1	1		
4	17921-ZVA-000	HOLDER, CABLE	1	1		
5	17930-ZVA-000	ARM COMP., THROTTLE	1	1		
6	17932-ZVA-000	SPRING, THROTTLE ARM	1	1		
7	53101-ZW6-C00ZA	HANDLE, STEERING *NH246*.....LOOSEY GRAY	1	1		
8	53104-ZVA-000	BOLT, FRICTION	1	1		
9	53106-ZVA-000	BLOCK, THROTTLE FRICTION	1	1		
10	53107-ZVA-000	COLLAR, HANDLE MOUNTING	2	2		
11	53108-ZVA-000	RUBBER, HANDLE MOUNTING	1	1		
12	53140-ZVA-000	GRIP COMP., THROTTLE	1	1		
13	53167-ZVA-000	HOUSING, UNDER THROTTLE	1	1		
14	53168-ZVA-000	HOUSING, UPPER THROTTLE	1	1		
15	90101-ZVA-000	BOLT, HEX., 6X24	1	1		
16	90102-ZVA-000	BOLT, SPECIAL, 8X42	1	1		
17	90117-ZVA-000	BOLT, FLANGE, 6X12	2	2		
18	90302-ZVA-000	NUT, HEX., 6MM	1	1		
19	90501-ZVA-000	WASHER, PLAIN, 8MM	1	1		
20	90509-ZVA-000	WASHER, 32MM	1	1		
21	90511-ZVA-000	WASHER, PLAIN, 6MM	1	1		
22	91553-ZVA-000	COLLAR, 6.2X8.5X5	2	2		
23	93500-05020-4J	SCREW, PAN, 5X20	2	2		
24	94001-05490-0S	NUT, HEX., 5MM	2	2		
25	94001-06490-0S	NUT, HEX., 6MM	1	1		

F-3

EXTENSION CASE

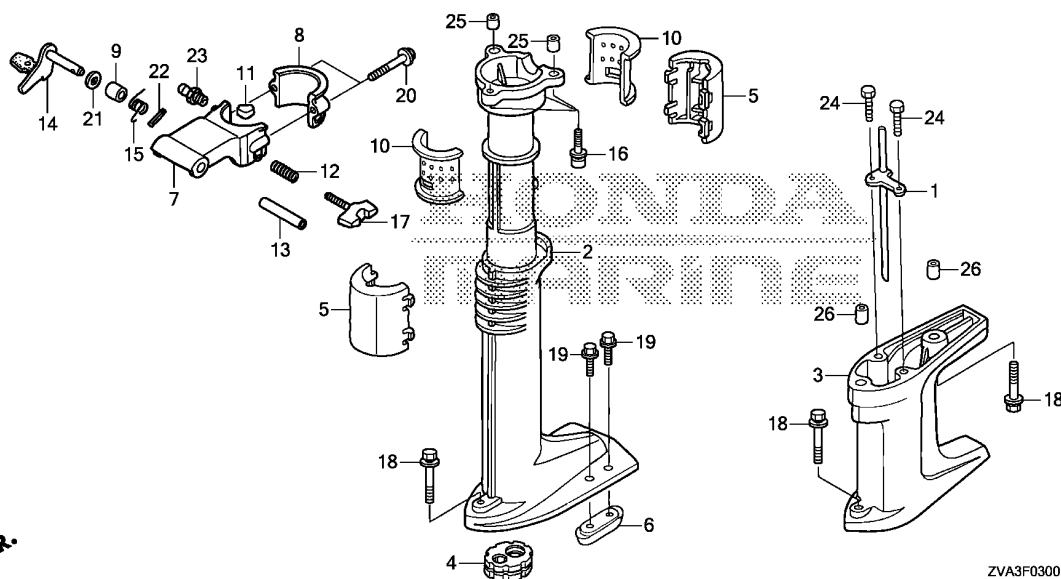

Ref. No.	L.O.N.	(Relative ref. Number) Description	F.R.T.
1	4131V8	TUBE, EXTENSION CASE WATER ...	0.4
2	2191B2	CASE, EXTENSION	0.5
3	2101W8	SEPARATOR, GEAR CASE EXTENSION	0.4
4	2191A4	BUSH, VERTICAL SHAFT	0.4
5	4141Q0	PROTECTOR, EXTENSION	0.1
.NOTE: Same time for two units			
6	2101V1	METAL, GEAR CASE ANODE	0.1
10	4131N2	LINER, SWIVEL CASE	0.2
.NOTE: Same time for two units			

ZVA3F0300

Ref. No.	Part No.	Description	Reqd. QTY		Serial No.	Parts catalogue code
			BF	2.3DH		
			(1)	(2)		
1	19250-ZVA-610	TUBE COMP., WATER	1	-	-----	LCHD,LCHU
2	40201-ZW6-C00ZA	CASE, EXTENSION *NH246*.....LOOSEY GRAY	1	1	-----	
3	40202-ZW6-C00ZA	SEPARATOR, EXTENSION *NH246*.....LOOSEY GRAY	1	-	-----	LCHD,LCHU
4	40210-ZVA-000	BUSH COMP., VERTICAL SHAFT(S)	1	1	-----	SCHD,SCHH,SCHU
	40210-ZVA-610	BUSH COMP., VERTICAL SHAFT(L)	1	-	-----	LCHD,LCHU
5	40218-ZVA-000	PROTECTOR, EXTENSION	2	2	-----	
6	41106-ZV4-650	METAL, ANODE	1	1	-----	SCHD,SCHH,SCHU
7	50201-ZW6-C00ZA	CASE, SWIVEL *NH246*.....LOOSEY GRAY	1	1	-----	
8	50203-ZVA-000ZA	CAP, SWIVEL CASE *NH246*.....LOOSEY GRAY	1	1	-----	
9	50204-ZVA-000	COLLAR, SWIVEL CASE	1	1	-----	
10	50211-ZVA-000	LINER, SWIVEL CASE	2	2	-----	
11	50212-ZVA-000	BLOCK, FRICTION	1	1	-----	
12	50233-ZVA-000	SPRING, FRICTION ADJUSTING ..	1	1	-----	
13	50337-ZVA-000	COLLAR, DISTANCE	1	1	-----	
14	50511-ZVA-000	ARM COMP., TILT LOCK	1	1	-----	
15	50516-ZVA-000	SPRING, TILT LOCK	1	1	-----	
16	90104-ZVA-000	BOLT-WASHER, SOCKET, 6X30 ...	3	3	-----	
17	90106-ZVA-000	BOLT, SWIVEL CASE	1	1	-----	
18	90109-ZVA-000	BOLT-WASHER, 6X35	1	1	-----	SCHD,SCHH,SCHU
			3	-	-----	LCHD,LCHU
19	90113-ZVA-000	BOLT, FLANGE, 6X16	2	2	-----	SCHD,SCHH,SCHU
20	90114-ZVA-000	BOLT, FLANGE, 8X35	2	2	-----	

F-3

EXTENSION CASE

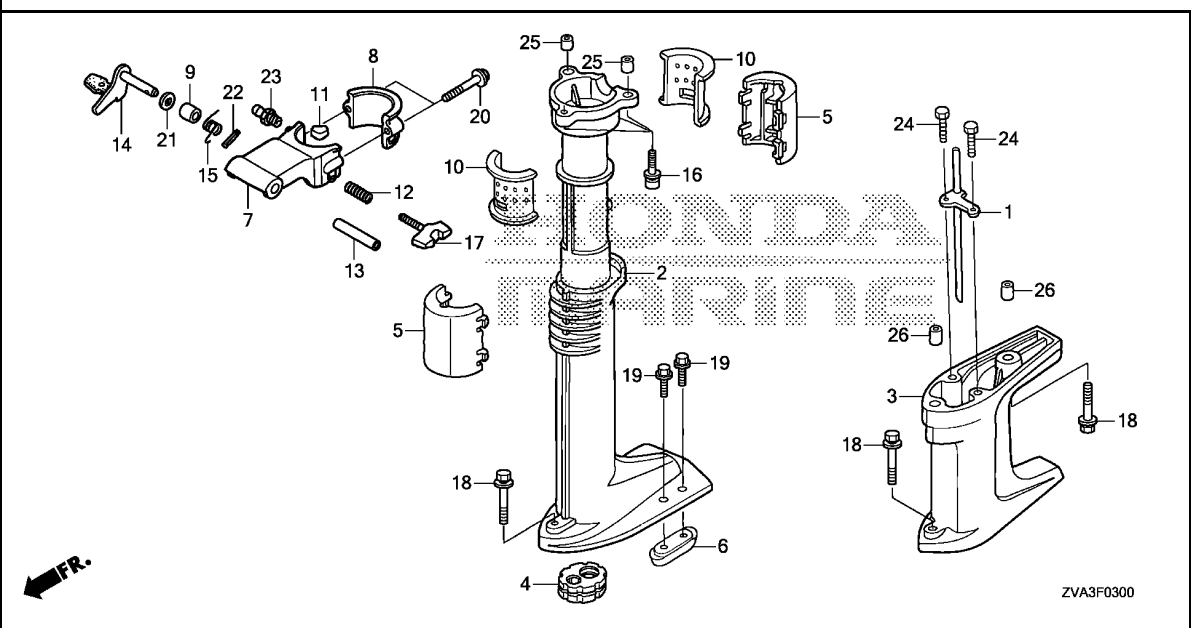

Ref. No.	Part No.	Description	Reqd. QTY		Serial No.	Parts catalogue code
			BF	2.3DH		
			(1)	(2)		
21	90518-ZVA-000	WASHER, PLAIN, 8MM	1	1		
22	90752-ZVA-000	PIN, SPRING, 2.5X20	1	1		
23	90951-ZV7-010	NIPPLE, GREASE	1	1		
24	92101-05016-4J	BOLT, HEX., 5X16	2	-	-----	LCHD,LCHU
25	94301-08100	DOWEL PIN, 8X10	2	2		
26	94301-08140	DOWEL PIN, 8X14	2	-	-----	LCHD,LCHU

F-5

GEAR CASE/PROPELLER

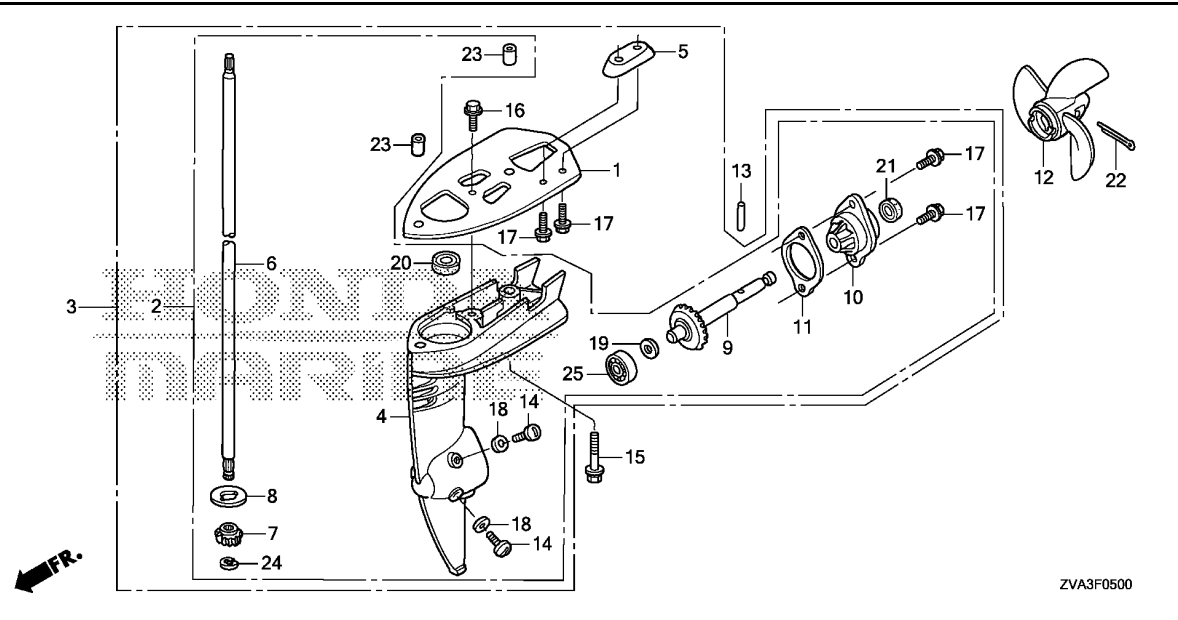

Ref. No.	L.O.N.	(Relative ref. Number) Description	F.R.T.
1	4141Q1	PLATE, CAVITATION	0.4
3		(2)	
	2101D3	CASE ASSEMBLY, GEAR	0.2
4	2101D7	CASE, GEAR	0.4
6	2191A9	SHAFT, VERTICAL	0.5
7	2091B5	GEAR, VERTICAL SHAFT PINION ..	0.3
9	2131K1	SHAFT, PROPELLER	0.3
10		(11)	
	2191A6	HOLDER, PROPELLER SHAFT	0.2
12	2191A8	PROPELLER, THREE BLADES	0.1
20	2191B1	WATER SEAL, VERTICAL SHAFT ...	0.4
21	2131P3	WATER SEAL, PROPELLER SHAFT ..	0.2
25	2191C0	BEARING, PROPELLER SHAFT	0.3

3

Ref. No.	Part No.	Description	Reqd. QTY	Serial No.	Parts catalogue code
			BF 2.3DH (1) (2)		
1	40205-ZVA-000ZA	PLATE, CAVITATION *NH246*.....LOOSEY GRAY	1	-	----- LCHD,LCHU
2	41005-ZVA-000ZA	CASE ASSY., GEAR(S) *NH246*.....LOOSEY GRAY	1	1	----- SCHD,SCHH,SCHU
3	41005-ZVA-610ZA	CASE ASSY., GEAR(L) *NH246*.....LOOSEY GRAY	1	-	----- LCHD,LCHU
4	41100-ZVA-000ZA	CASE COMP., GEAR *NH246*.....LOOSEY GRAY	1	1	
5	41106-ZV4-650	METAL, ANODE	1	-	----- LCHD,LCHU
6	41112-ZW6-C00	SHAFT, VERTICAL(S)	1	1	----- SCHD,SCHH,SCHU
	41112-ZW6-C10	SHAFT, VERTICAL(L)	1	-	----- LCHD,LCHU
7	41131-ZVA-000	GEAR, PINION	1	1	
8	41135-ZVA-000	WASHER, PINION THRUST	1	1	
9	41160-ZVA-000	SHAFT COMP., PROPELLER	1	1	
10	41200-ZW6-C10ZA	HOLDER ASSY., PROPELLER SHAFT *NH246*.....LOOSEY GRAY	1	1	
11	41281-ZVA-000	PACKING, PROPELLER SHAFT HOLDER	1	1	
12	58130-ZV0-841ZB	PROPELLER COMP., THREE BLADES *NH283*.....STIN GRAY	1	1	
13	58131-ZV0-000	PIN, SHEAR	1	1	
14	90105-ZVA-000	BOLT, OIL CHECK	2	2	
15	90109-ZVA-000	BOLT-WASHER, 6X35	1	1	
16	90112-ZVA-000	BOLT, FLANGE, 6X12	1	-	----- LCHD,LCHU
17	90113-ZVA-000	BOLT, FLANGE, 6X16	2	2	----- SCHD,SCHH,SCHU
			4	-	----- LCHD,LCHU

F-5

GEAR CASE/PROPELLER

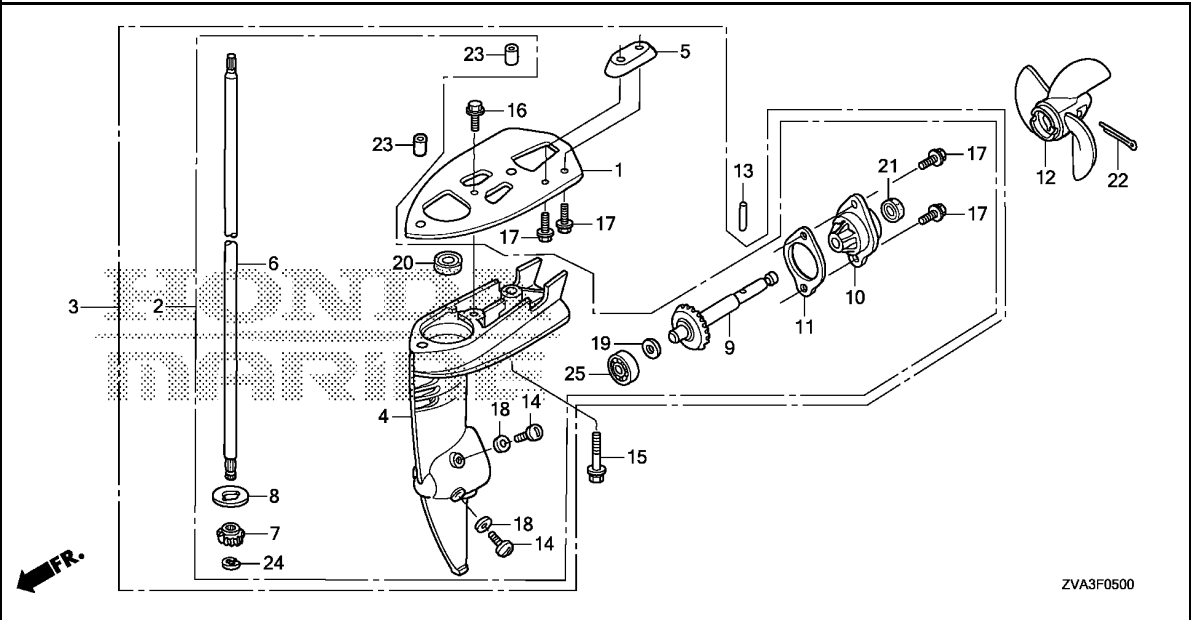

Ref. No.	Part No.	Description	Reqd. QTY		Serial No.	Parts catalogue code
			BF	2.3DH		
			(1)	(2)		
18	90507-ZVA-000	WASHER, NYLON, 8MM	2	2		
19	90531-ZVA-000	WASHER, GEAR	1	1		
20	91251-ZV0-003	WATER SEAL, 11X21X8	1	1		
21	91253-ZV0-003	WATER SEAL, 11X21X8	1	1		
22	94201-30402	PIN, SPLIT, 3.0	1	1		
23	94301-08140	DOWEL PIN, 8X14	2	2		
24	94540-06018	E-RING, 6MM	1	1		
25	96100-60000-00	BEARING, RADIAL BALL, 6000 ..	1	1		

F-8

ENGINE COVER

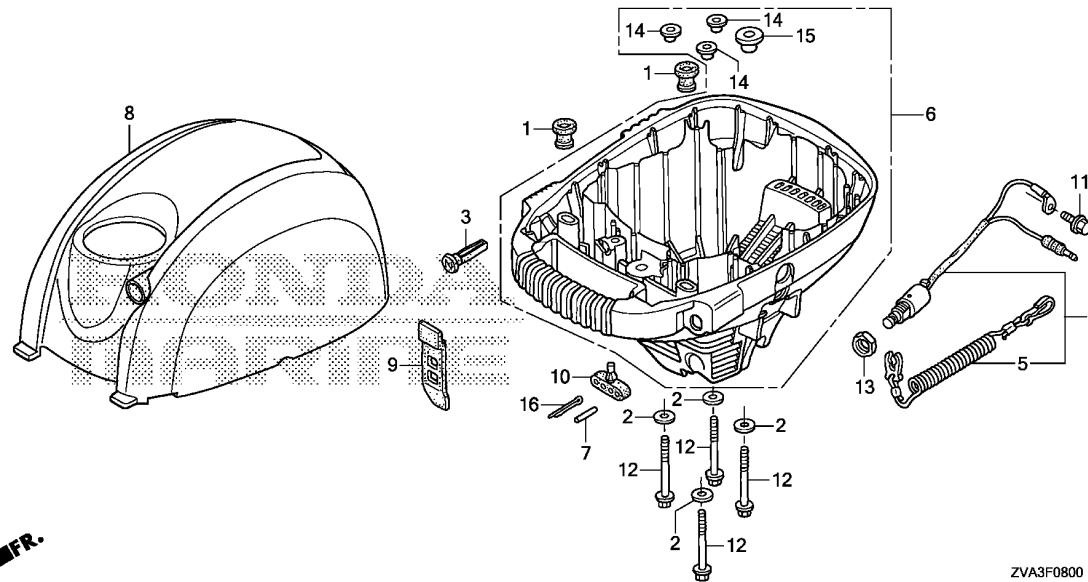

Ref. No.	L.O.N.	(Relative ref. Number) Description	F.R.T.
1	3101D1	RUBBER, TANK MOUNTING	0.2
3	8101Q0	KNOB, CHOKE	0.1
4	6151B8	SWITCH, EMERGENCY STOP	0.2
6	4141L2	CASE, ENGINE UNDER	1.4
		.INCLUDES: Engine removal and installation	
8	4141B4	COVER, ENGINE	0.1

Ref. No.	Part No.	Description	Reqd. QTY		Serial No.	Parts catalogue code
			BF	2.3DH		
			(1)	(2)		
1	17514-ZVA-000	RUBBER, TANK MOUNTING(C)	2	2		
2	17936-ZVA-000	WASHER, PLAIN, 6MM	4	4		
3	17951-ZVA-000	KNOB, CHOKE	1	1		
4	35180-ZW6-023	SWITCH ASSY., EMERGENCY STOP	1	1		
5	36182-ZV4-651	CORD COMP., EMERGENCY	1	1		
6	40100-ZVA-000	CASE COMP., ENGINE UNDER	1	1		
7	58131-ZV0-000	PIN, SHEAR	1	1		
8	63100-ZVA-000ZA	COVER COMP., ENGINE *NHB14M*	1	1		
9	63103-ZVA-000	AQUA MARINE SILVER METALLIC BELT, ENGINE COVER	1	1		
10	88111-ZVA-000	HOLDER, PARTS	1	1		
11	90019-ZW4-000	BOLT, FLANGE, 5X10	1	1		
12	90103-ZVA-000	BOLT, FLANGE, 6X60	4	4		
13	90303-ZVA-000	NUT, HEX., 16MM	1	1		
14	91551-ZVA-000	COLLAR, 6X4	3	3		
15	91552-ZVA-000	COLLAR, ENGINE UNDER CASE ...	1	1		
16	94201-30402	PIN, SPLIT, 3.0	1	1		

3

F-10

STERN BRACKET

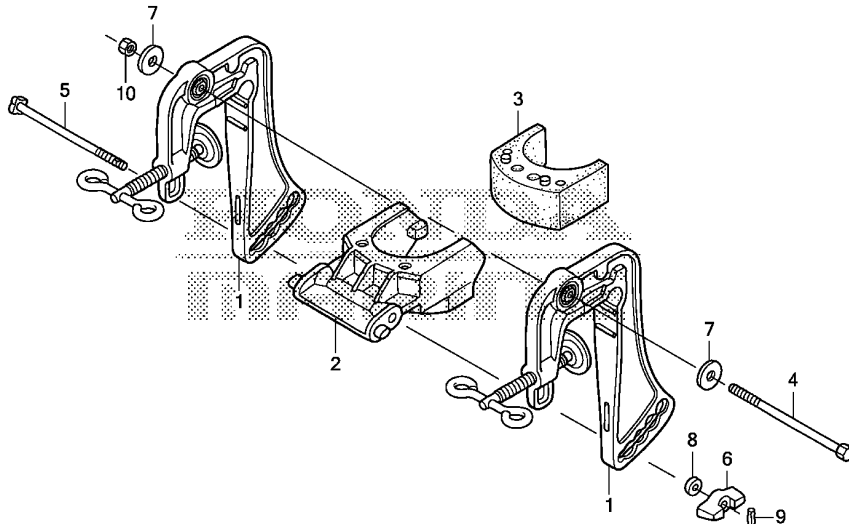

FR.

ZVA3F1000

Ref. No.	L.O.N.	(Relative ref. Number) Description	F.R.T.
1	413128	BRACKET, STERN :LEFT	0.2
	413129	BRACKET, STERN :RIGHT	0.2
2	4131W1	RECEIVER, THRUST	0.2
3	4131W2	RUBBER, THRUST	0.2

Ref. No.	Part No.	Description	Reqd. QTY		Serial No.	Parts catalogue code
			BF	2.3DH		
			(1)	(2)		
1	50300-ZVA-000ZA	BRACKET COMP., STERN *NH246*.....LOOSEY GRAY	2	2		
2	50302-ZVA-000	RECEIVER, THRUST	1	1		
3	50303-ZVA-000	RUBBER COMP., THRUST	1	1		
4	90107-ZVA-000	BOLT, HEX., 8X110	1	1		
5	90108-ZVO-000	BOLT, DIAMOND, 6X110	1	1		
6	90301-ZVA-000	NUT, WING	1	1		
7	90501-ZVA-000	WASHER, PLAIN, 8MM	2	2		
8	90512-ZVA-000	WASHER, PLAIN, 6MM	1	1		
9	90751-ZVA-000	PIN, SPRING, 2.5X8	1	1		
10	94001-08490-0S	NUT, HEX., 8MM	1	1		

F-12

LABEL

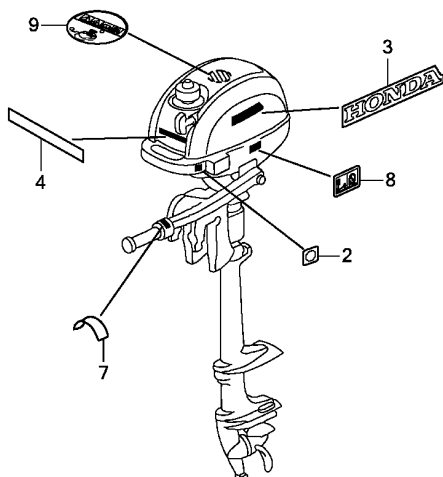
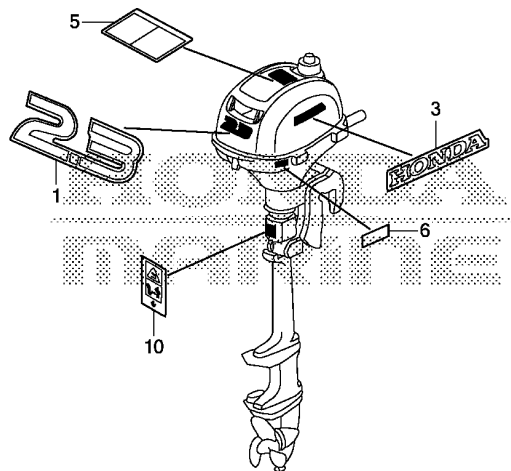

ZVA3F1200

Ref. L.O.N. (Relative ref. Number) F.R.T.
No. Description

NO INFORMATION

3

Ref. No.	Part No.	Description	Reqd. QTY		Serial No.	Parts catalogue code
			BF 2.3DH (1)	(2)		
1	87121-ZW6-G81	MARK, RR.(2.3)	1	1		
2	87124-ZVA-000	MARK, EMERGENCY SWITCH INDICATION	1	1		
3	87132-ZW6-B00	MARK, SIDE STRIPE(HONDA)	2	2		
4	87302-ZY1-C00	MARK, FOUR STROKE	1	1	-----	LCHD,SCHD,SCHH
5	87516-ZVA-D00	MARK, OPERATOR CAUTION	1	1		
6	87521-ZVA-000	MARK, FUEL COCK	1	1		
7	87533-ZVA-000	MARK, THROTTLE	1	1		
8	87535-ZVA-E00	LABEL, STORING CAUTION(EU) ..	1	1	-----	LCHU,SCHH,SCHU
9	87537-ZVA-E00	LABEL, RECOIL CAUTION(EU) ..	1	1		
10	87539-ZVA-E00	MARK, EX. CAUTION	1	1		

F-13

TOOL

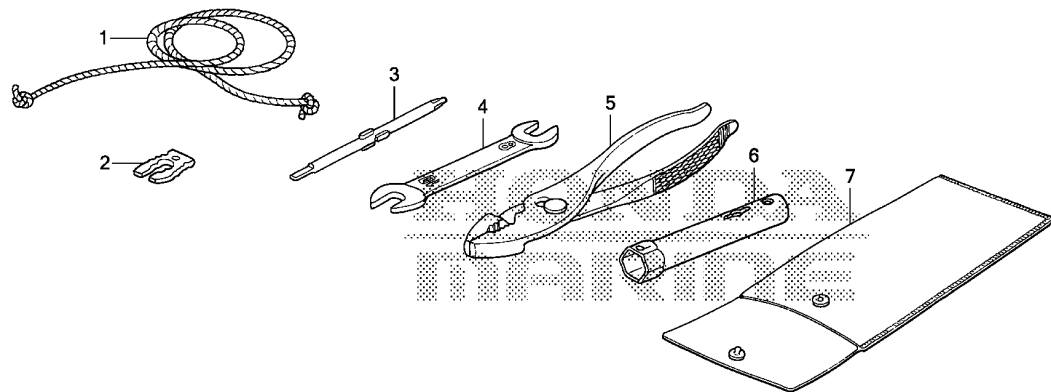

ZVA3F1300

Ref. L.O.N. (Relative ref. Number) F.R.T.
No. Description

NO INFORMATION

Ref. No.	Part No.	Description	Reqd. QTY		Serial No.	Parts catalogue code
			BF 2.3DH (1)	(2)		
1	28462-ZVA-A00	ROPE, STARTER	1	1		
2	36187-ZV4-652	CLIP, EMERGENCY LOCK	1	1		
3	89102-KSH-900	DRIVER, SCREW(NO.2 +/-)	1	1		
4	89203-ZVA-000	SPANNER, 8X10	1	1		
5	89213-KWK-900	PLIERS	1	1		
6	89216-ZVA-000	WRENCH, BOX(P16)	1	1		
7	99008-01600	BAG, TOOL, 160MM	1	1		



PART NO. INDEX

Part Number	Page	Ref.	Part Number	Page	Ref.	Part Number	Page	Ref.	Part Number	Page	Ref.	Part Number	Page	Ref.
11000			16024-ZW6-003	27	7	18000			40205-ZVA-000ZA	36	1	87000		
			16028-ZW6-003	27	8				40210-ZVA-000	34	4			
11300-ZW6-T00	17	1	16028-ZW6-611	27	9	18330-ZVA-000	30	1	40210-ZVA-610	34	4	87121-ZW6-G81	40	1
11316-ZVA-000	17	2	16044-ZV0-A01	27	10	18515-ZVA-000	30	2	40218-ZVA-000	34	5	87124-ZVA-000	40	2
11340-ZW6-T00	18	1	16081-ZV1-A00	27	11							87132-ZW6-B00	40	3
			16082-ZW6-003	27	12	19000			41000			87302-ZY1-C00	40	4
12000			16100-ZVA-003	27	13							87516-ZVA-D00	40	5
			16100-ZVA-E01	27	13	19250-ZVA-610	34	1	41005-ZVA-000ZA	36	2	87521-ZVA-000	40	6
12100-ZW6-T00	16	1	16166-ZW6-G01	27	14	19610-ZVA-000	25	2	41005-ZVA-610ZA	36	3	87533-ZVA-000	40	7
12209-ZM7-003	21	1	16196-ZVA-000	27	15	19618-ZVA-000	25	3	41100-ZVA-000ZA	36	4	87535-ZVA-E00	40	8
12311-ZVA-000ZA	16	2	16197-ZVA-000	27	16	19619-ZVA-300	25	4	41106-ZV4-650	34	6	87537-ZVA-E00	40	9
12367-ZE6-020	16	3	16202-ZVA-000	29	2	19631-ZVA-000	16	11		36	5	87539-ZVA-E00	40	10
			16211-ZVA-000	27	17				41112-ZW6-C00	36	6			
13000			16212-ZVA-000	27	18	22000			41112-ZW6-C10	36	6	88000		
			16221-ZVA-000	27	19				41131-ZVA-000	36	7			
13010-ZW6-000	20	1	16225-ZVA-000	27	20	22000-ZW6-701	26	1	41135-ZVA-000	36	8	88111-ZVA-000	38	10
13101-ZW6-010	20	2	16512-ZM7-D00	18	2	22100-ZW6-704	26	2	41160-ZVA-000	36	9			
13111-ZVA-000	20	3	16576-ZVA-000	25	1	22214-ZW6-703	26	3	41200-ZW6-C10ZA	36	10	89000		
13115-ZVA-000	20	4				22252-ZW6-701	26	4	41281-ZVA-000	36	11			
13200-ZN4-010	20	5	16674-ZVA-000	27	21	22253-ZW6-700	26	5				89102-KSH-900	41	3
13310-ZN4-020	19	1	16952-ZVA-000	31	1	22254-ZW6-700	26	6	50000			89203-ZVA-000	41	4
13331-ZVA-000	19	2	16953-ZW6-003	27	22	22255-ZVA-000	26	7				89213-KWK-900	41	5
			16954-ZW6-003	27	23	22260-ZVA-000	26	8	50201-ZW6-C00ZA	34	7	89216-ZVA-000	41	6
14000			16956-ZE1-811	27	24				50203-ZVA-000ZA	34	8			
			16957-ZE1-812	28	25	28000			50204-ZVA-000	34	9	90000		
			16958-ZVA-000	28	26				50211-ZVA-000	34	10			
14111-ZVA-000	21	2				28400-ZVA-003	24	1	50212-ZVA-000	34	11	90001-ZM7-000	20	6
14126-Z0G-003	21	3				28451-ZVA-003	32	1	50233-ZVA-000	34	12	90002-ZVA-000	29	9
14410-ZVA-000	21	4	17000			28461-ZVA-003	24	2	50300-ZVA-000ZA	39	1	90003-ZVA-000	16	13
14431-ZVA-000	21	5				28462-ZVA-A00	41	1	50302-ZVA-000	39	2	90004-ZW4-000	32	5
14435-ZM7-003	21	6	17201-ZVA-000	29	3	28462-ZW6-003	24	3	50303-ZVA-000	39	3	90005-ZVA-000	29	10
14451-ZM7-000	21	7	17202-ZVA-300	29	4				50337-ZVA-000	34	13	90007-ZVA-000	30	3
14711-ZW6-000	21	8	17204-ZVA-300	29	5				50511-ZVA-000	34	14	90008-ZM7-000	16	14
14721-ZW6-000	21	9	17371-ZVA-000	29	6	30000			50516-ZVA-000	34	15	90009-ZVA-000	16	15
14731-ZM7-013	21	10	17374-ZVA-000	29	7							90012-ZVA-000	28	27
14751-ZM7-000	21	11	17375-ZVA-000	29	8	30500-ZVA-003	32	2	53000			90017-ZVA-000	16	16
14754-ZVA-000	21	12	17511-ZVA-000	31	2							90019-ZV1-010	16	17
14771-ZM3-010	21	13	17514-ZVA-000	38	1	31000			53101-ZW6-C00ZA	33	7	17	4	91553-ZVA-000
			17515-ZVA-E10	31	3				53104-ZVA-000	33	8	90019-ZW4-000	38	11
15000			17531-ZVA-000	31	4	31110-ZVA-003	32	3	53106-ZVA-000	33	9	90042-ZM7-000	25	5
			17620-ZVA-000	31	5	31914-Z8Y-003	16	12	53107-ZVA-000	33	10	90043-ZM7-000	25	6
15171-ZN4-000	16	4	17621-ZVA-000	31	6				53108-ZVA-000	33	11	90049-ZVA-000	29	11
15361-ZN4-000	21	14	17622-ZVA-000	31	7	32000			53140-ZVA-000	33	12	90058-ZVA-000	25	7
15571-ZM7-003	16	5	17623-ZV0-000	31	8				53167-ZVA-000	33	13	90101-ZVA-000	33	15
15572-ZM7-000	16	6	17624-ZVA-000	31	9	32195-ZVA-003	32	4	53168-ZVA-000	33	14	90102-ZVA-000	33	16
15600-Z1T-600	16	7	17625-ZVA-000	31	10							90103-ZVA-000	38	12
15622-ZVA-000	16	8	17626-ZVA-000	31	11	35000			58000			90104-ZVA-000	34	16
15625-Z1T-000	16	9	17629-ZVA-000	31	12							90105-ZVA-000	36	14
15661-ZV0-003	16	10	17633-ZVA-000	31	13	35180-ZW6-023	38	4	58130-ZV0-841ZB	36	12	90106-ZVA-000	34	17
15721-ZVA-000	29	1	17701-ZVA-000	31	14				58131-ZV0-000	36	13	90107-ZVA-000	39	4
15723-ZVA-000	17	3	17910-ZVA-003	33	2	36000						90108-ZV0-000	39	5
			17920-ZVA-000	33	3							90109-ZVA-000	34	18
16000			17921-ZVA-000	33	4	36182-ZV4-651	38	5	63000			36	15	94001-06490-OS
			17930-ZVA-000	33	5	36187-ZV4-652	41	2				36	16	94001-08490-OS
16010-ZW6-611	27	1	17932-ZVA-000	33	6				63100-ZVA-000ZA	38	8	36	19	94021-06020-OS
16011-ZE0-005	27	2	17936-ZVA-000	38	2	40000			63103-ZVA-000	38	9	36	17	94201-30402
16013-ZG0-811	27	3	17951-ZVA-000	38	3							36	17	94301-06100
16015-ZW6-G01	27	4				40100-ZVA-000	38	6				34	20	94301-08100
16016-ZW6-003	27	5				40201-ZW6-C00ZA	34	2				33	17	
16016-ZW6-E11	27	6				40202-ZW6-C00ZA	34	3				17	5	

PART NO. INDEX

Part Number	Page Ref.	Part Number	Page Ref.	Part Number	Page Ref.	Part Number	Page Ref.	Part Number	Page Ref.
94301-08140	35 26								
	37 23								
94540-06018	37 24								
95000									
95002-02109	31 19								
95002-02129	31 20								
96000									
96100-60000-00	37 25								
96220-60150	16 21								
99000									
99008-01600	41 7								
99101-ZG0-0580	28 28								
99101-ZG0-0600	28 28								
99101-ZG0-0620	28 28								
99204-ZE0-0350	28 29								

PART NAME INDEX

Part name	Page	Ref.	Part name	Page	Ref.	Part name	Page	Ref.
[A]			CABLE COMP. B, THROTTLE	33	3	FLYWHEEL COMP.	32	3
ARM COMP., THROTTLE	33	5	CAMSHAFT	21	2	[G]		
ARM COMP., TILT LOCK	34	14	CAP ASSY., FUEL TANK	31	5	GASKET SET	27	1
ARM, VALVE ROCKER	21	5	CAP ASSY., OIL FILLER	16	7	GEAR, PINION	36	7
[B]			CAP, SWIVEL CASE	34	8	GRIP COMP., THROTTLE	33	12
BAG, TOOL, 160MM	41	7	CARBURETOR ASSY.	27	13	GROMMET, FAN COVER	25	3
BARREL COMP., CYLINDER	16	1	CASE ASSY., GEAR	36	2	GROMMET, FUEL TANK	31	4
BEARING, RADIAL BALL, 6000 ...	37	25	CASE ASSY., OIL	17	1	GROMMET, SILENCER	29	7
BELT, ENGINE COVER	38	9	CASE COMP., ENGINE UNDER	38	6	GUIDE, AIR EX.	30	2
BLOCK, FRICTION	34	11	CASE COMP., GEAR	36	4	GUIDE, AIR INLET	29	3
BLOCK, THROTTLE FRICTION	33	9	CASE COMP., SILENCER	29	6	[H]		
BODY, FUEL CAP	31	6	CASE, EXTENSION	34	2	HANDLE, STEERING	33	7
BOLT-WASHER, 5X16	21	18	CASE, SWIVEL	34	7	HOLDER ASSY., PROPELLER SHAFT ..	36	10
BOLT-WASHER, 6X35	34	18	CHAMBER SET, FLOAT	27	4	HOLDER, CABLE	25	1
BOLT-WASHER, SOCKET, 6X30	36	15	CLIP, EMERGENCY LOCK	41	2	HOLDER, GOVERNOR WEIGHT	33	1
BOLT A, STUD	25	5	CLIP, GOVERNOR HOLDER	18	5	HOLDER, PARTS	38	10
BOLT B, STUD	25	6	CLIP, PISTON PIN, 10MM	20	4	HOUSING ASSY., CLUTCH	26	8
BOLT, 4X10	16	14	CLIP, TUBE	31	19	HOUSING, UNDER THROTTLE	33	13
BOLT, CLUTCH	26	5	CLUTCH ASSY.	26	1	HOUSING, UPPER THROTTLE	33	14
BOLT, CLUTCH STAY	26	7	COIL ASSY., IGNITION	32	2	[I]		
BOLT, CONNECTING ROD	20	6	COLLAR, 6X4	38	14	INNER, FUEL CAP	31	7
BOLT, DIAMOND, 6X110	39	5	COLLAR, 6.2X8.5X5	33	22	INSULATOR, CARBURETOR	27	17
BOLT, FLANGE, 5X10	16	17	COLLAR, 6.5X7.5	31	16	[J]		
	17	4	COLLAR, DISTANCE	29	4	JET SET, PILOT, #35	28	29
	25	7			5	JET, MAIN, #58	28	28
	38	11	COLLAR, ENGINE UNDER CASE	38	15	JET, MAIN, #60	28	28
BOLT, FLANGE, 5X12	16	15	COLLAR, FAN COVER	25	4	JET, MAIN, #62	28	28
	29	11	COLLAR, HANDLE MOUNTING	33	10	JOINT, AIR VENT TUBE	28	26
BOLT, FLANGE, 5X16	16	13	COLLAR, LIFTER	21	12	[K]		
	30	3	COLLAR, SWIVEL CASE	34	9	KEY, SPECIAL	19	2
BOLT, FLANGE, 5X20	32	5	CORD COMP., EMERGENCY	38	5	KNOB, CHOKE	38	3
BOLT, FLANGE, 5X23	17	5	CORD, STOP SWITCH	32	4	KNOB, STARTER	24	2
	18	3	COVER COMP., CRANKCASE SIDE ...	18	1	[L]		
BOLT, FLANGE, 5X62	29	9	COVER COMP., ENGINE	38	8	LABEL, RECOIL CAUTION	40	9
BOLT, FLANGE, 5X70	29	10	COVER COMP., FAN	25	2	LABEL, STORING CAUTION	40	8
BOLT, FLANGE, 6X12	33	17	COVER, HEAD	16	2	LEVER SET, CHOKE	27	10
	36	16	COVER, HEAD	16	2	LEVER, COCK	27	22
BOLT, FLANGE, 6X16	34	19	CRANKSHAFT COMP.	19	1	LIFTER, VALVE	21	10
	36	17	[D]			LINER, SWIVEL CASE	34	10
BOLT, FLANGE, 6X60	38	12	DOWEL PIN, 6X10	18	7	[M]		
BOLT, FLANGE, 8X35	34	20	DOWEL PIN, 8X10	35	25	MARK, EMERGENCY SWITCH		
BOLT, FRICTION	33	8	DOWEL PIN, 8X14	35	26	INDICATION	40	2
BOLT, HEX., 5X16	35	24	DRIVER, SCREW	37	23	MARK, EX. CAUTION	40	10
BOLT, HEX., 6X24	33	15		41	3	[C]		
BOLT, HEX., 8X110	39	4	[E]			FILTER, BREATHER	16	3
BOLT, OIL CHECK	16	16	E-RING, 6MM	37	24	FINDER, OIL LEVEL	16	10
	36	14	EXTENSION, OIL LEVEL FINDER ...	16	8	FLOAT SET	27	3
BOLT, SPECIAL, 8X42	33	16	[F]					
BOLT, SWIVEL CASE	34	17	FILTER, BREATHER	16	3			
BRACKET COMP., STERN	39	1	FINDER, OIL LEVEL	16	10			
BUSH COMP., VERTICAL SHAFT ...	34	4	FLOAT SET	27	3			
[C]								
CABLE COMP. A, THROTTLE	33	2						

1

FOREWORD INDEX

2

ENGINE GROUP

3

FRAME GROUP

4

PART NUMBER INDEX

5

PART NAME INDEX

HONDA
The Power of Dreams



PARTS CATALOGUE NEWS

Service Technology Department, Power Products Operations
 Service Division, Honda Motor Co., Ltd.

PARTS CATALOGUE - CORRECTED

Printed in Japan

CODE NO.	13ZVAG01
PARTS CATALOGUE NEWS	BF2.3DH
NEWS NO.	001

Block No.	Ref. No.	Note	Part No.	Description	Reqd. QTY		Serial No.	Parts catalogue code
					BF (1)	2.3DH (2)		
E-17	1	D	16952-ZE6-000	STRAINER, FUEL.....	1	1		
		E	16952-ZVA-000	*PART NO. DELETION				

NOTE A:PART NO. CHANGE D:NEWLY PROVIDED E:PART NO. DELETION K:REQUIRED NO. CORRECTION L:APPLICATION SERIAL NO. CORRECTION
 M:PART DESCRIPTION CORRECTION T:APPLICATION CORRECTION Z:REMARKS CHANGE