

## How to use this manual

---

# A Few Words About Safety

## Service Information

The service and repair information contained in this manual is intended for use by qualified, professional technicians. Attempting service or repairs without the proper training, tools, and equipment could cause injury to you and/or others. It could also damage this Honda product or create an unsafe condition.

This manual describes the proper methods and procedures for performing service, maintenance, and repairs. Some procedures require the use special tools. Any person who intends to use a replacement part, service procedure, or a tool that is not recommended by Honda must determine the risks to their personal safety and the safe operation of this product.

If you need to replace a part, use Honda Genuine parts with the correct part number or an equivalent part. We strongly recommend that you do not use replacement parts of inferior quality.

## For Your Customer's Safety

Proper service and maintenance are essential to the customer's safety and the reliability of this product. Any error or oversight while servicing this product can result in faulty operation, damage to the product, or injury to others.

### **⚠ WARNING**

Improper service or repairs can create an unsafe condition that can cause your customer or others to be seriously hurt or killed.

Follow the procedures and precautions in this manual and other service materials carefully.

## For Your Safety

Because this manual is intended for the professional service technician, we do not provide warnings about many basic shop safety practices (e.g., Hot parts-wear gloves). If you have not received shop safety training or do not feel confident about your knowledge of safe servicing practices, we recommend that you do not attempt to perform the procedures described in this manual.

Some of the most important general service safety precautions are given below. However, we cannot warn you of every conceivable hazard that can arise in performing service and repair procedures. Only you can decide whether or not you should perform a given task.

### **⚠ WARNING**

Failure to properly follow instructions and precautions can cause you to be seriously hurt or killed.

Follow the procedures and precautions in this manual carefully.

## Important Safety Precautions

Make sure you have a clear understanding of all basic shop safety practices and that you are wearing appropriate clothing and using safety equipment. When performing any service task, be especially careful of the following:

- Read all of the instructions before you begin, and make sure you have the tools, the replacement or repair parts, and the skills required to perform the tasks safely and completely.
- Protect your eyes by using proper safety glasses, goggles, or face shields anytime you hammer, drill, grind, or work around pressurized air, pressurized liquids, springs, or other stored-energy components. If there is any doubt, put on eye protection.
- Use other protective wear when necessary, for example gloves or safety shoes. Handling hot or sharp parts can cause severe burns or cuts. Before you grab something that looks like it can hurt you, stop and put on gloves.
- Protect yourself and others whenever you have equipment hoisted in the air. Anytime you lift this product with a hoist, make sure that the hoist hook is securely attached to the product.

Make sure the engine is off before you begin any servicing procedures, unless the instruction tells you to do otherwise. This will help eliminate several potential hazards:

- Carbon monoxide poisoning from engine exhaust. Be sure there is adequate ventilation whenever you run the engine.
- Burns from hot parts. Let the engine and exhaust system cool before working in those areas.
- Injury from moving parts. If the instruction tells you to run the engine, be sure your hands, fingers, and clothing are out of the way.

Gasoline vapors and hydrogen gasses from batteries are explosive. To reduce the possibility of a fire or explosion, be careful when working around gasoline or batteries.

- Use only a nonflammable solvent, not gasoline, to clean parts.
  - Never store gasoline in an open container.
  - Keep all cigarettes, sparks, and flames away from the battery and all fuel-related parts.
-

---

## CONTENTS

<b>SPECIFICATIONS</b>	<b>1</b>
<b>SERVICE INFORMATION</b>	<b>2</b>
<b>MAINTENANCE</b>	<b>3</b>
<b>TROUBLESHOOTING</b>	<b>4</b>
<b>FUEL SYSTEM</b>	<b>5</b>
<b>GOVERNOR SYSTEM</b>	<b>6</b>
<b>IGNITION SYSTEM</b>	<b>7</b>
<b>STARTING SYSTEM</b>	<b>8</b>
<b>MUFFLER</b>	<b>9</b>
<b>ENGINE REMOVAL/INSTALLATION</b>	<b>10</b>
<b>CLUTCH</b>	<b>11</b>
<b>CYLINDER HEAD</b>	<b>12</b>
<b>CYLINDER BLOCK</b>	<b>13</b>
<b>HANDLE</b>	<b>14</b>
<b>ROTOR/TRANSMISSION</b>	<b>15</b>
<b>TECHNICAL FEATURE</b>	<b>16</b>
<b>INDEX</b>	

---

## How to use this manual

---

# INTRODUCTION

This manual covers the service and repair procedures for the Honda FJ500 tiller.

All information contained in this manual is based on the latest product information available at the time of printing. We reserve the right to make changes at anytime without notice.

No part of this publication may be reproduced, stored in a retrieval system, or transmitted, in any form, by any means, electronic, mechanical, photocopying, recording, or otherwise, without prior written permission of the publisher. This includes text, figures, and tables.

As you read this manual, you will find information that is preceded by a **NOTICE** symbol. The purpose of this message is to help prevent damage to this Honda product, other property, or the environment.

## SAFETY MESSAGES

Your safety and the safety of other are very important. To help you make informed decisions, we have provided safety messages and other safety information throughout this manual. Of course, it is not practical or possible to warn you about all the hazards associated with servicing these products. You must use your own good judgement.

You will find important safety information in a variety of forms, including:

- Safety Labels – on the product.
- Safety Messages – preceded by a safety alert symbol  and one of three signal words, DANGER, WARNING, or CAUTION. These signal words mean:

** DANGER** You WILL be KILLED or SERIOUSLY HURT if you don't follow instructions.

** WARNING** You CAN be KILLED or SERIOUSLY HURT if you don't follow instructions.

** CAUTION** You CAN be HURT if you don't follow instructions.

- Instructions – how to service these products correctly and safely.

ALL INFORMATION, ILLUSTRATIONS, DIRECTIONS, AND SPECIFICATIONS INCLUDED IN THIS PUBLICATION ARE BASED ON THE LATEST PRODUCT INFORMATION AVAILABLE AT THE TIME OF APPROVAL FOR PRINTING. Honda Motor Co., Ltd. RESERVES THE RIGHT TO MAKE CHANGES AT ANY TIME WITHOUT NOTICE AND WITHOUT INCURRING ANY OBLIGATION WHATSOEVER. NO PART OF THIS PUBLICATION MAY BE REPRODUCED WITHOUT WRITTEN PERMISSION. THIS MANUAL IS WRITTEN FOR PERSONS WHO HAVE ACQUIRED BASIC KNOWLEDGE OF MAINTENANCE ON Honda PRODUCTS.

© Honda Motor Co., Ltd.  
SERVICE PUBLICATION OFFICE

Date of Issue: November 2011

---









## SERVICE RULES

- Use Honda Genuine or Honda-recommended parts and lubricants or their equivalents. Parts that do not meet Honda's design specifications may damage the unit.
- Use the special tools designed for the product.
- Install new gaskets, O-rings, etc. when reassembling.
- When torquing bolts or nuts, begin with larger-diameter or inner bolts first and tighten to the specified torque diagonally, unless a particular sequence is specified.
- Clean parts in cleaning solvent upon disassembly. Lubricate any sliding surfaces before reassembly.
- After reassembly, check all parts for proper installation and operation.
- Many screws used in this machine are self-tapping. Be aware that cross-threading or overtightening these screws will strip the threads and ruin the hole.

Use only metric tools when servicing this unit. Metric bolts, nuts, and screws are not interchangeable with non-metric fasteners. The use of incorrect tools and fasteners will damage the unit.

## SYMBOLS

The symbols used throughout this manual show specific service procedures. If supplementary information is required pertaining to these symbols, it will be explained specifically in the text without the use of the symbols.

	Replace the part(s) with new one(s) before assembly.
	Use the recommend engine oil, unless otherwise specified.
	Use molybdenum oil solution (mixture of the engine oil and molybdenum grease in a ratio of 1:1).
	Use multi-purpose grease (lithium based multi-purpose grease NLGI #2 or equivalent).
	Use marine grease (water resistant urea based grease).
	Apply a locking agent. Use a medium strength locking agent unless otherwise specified.
	Apply sealant.
	Use automatic transmission fluid.
(O x O) (O)	Indicates the diameter, length, and quantity of metric bolts used.
page 1-1	Indicates the reference page.

## How to use this manual

# ABBREVIATIONS

Throughout this manual, the following abbreviations are used to identify the respective parts or systems.

Abbreviated term	Full term
ACG	Alternator
A/F	Air Fuel Ratio
API	American Petroleum Institute
Approx.	Approximately
Assy.	Assembly
ATDC	After Top Dead Center
ATF	Automatic Transmission Fluid
ATT	Attachment
BAT	Battery
BDC	Bottom Dead Center
BTDC	Before Top Dead Center
BARO	Barometric Pressure
CKP	Crankshaft Position
Comp.	Complete
CMP	Camshaft Position
CYL	Cylinder
DLC	Data Link Connector
EBT	Engine Block Temperature
ECT	Engine Coolant Temperature
ECM	Engine Control Module
EMT	Exhaust Manifold Temperature
EOP	Engine Oil Pressure
EX	Exhaust
F	Front or Forward
GND	Ground
HO <sub>2</sub> S	Heated Oxygen sensor
HST	Hydrostatic Transmission
IAB	Intake Air Bypass
IAC	Idle Air Control
IAT	Intake Air Temperature
I.D.	Inside diameter
IG or IGN	Ignition
IN	Intake
INJ	Injection
L.	Left
MAP	Manifold Absolute Pressure
MIL	Malfunction Indicator Lamp
O.D.	Outside Diameter
OP	Optional Part
PGM-FI	Programmed-Fuel Injection
P/N	Part Number
Qty	Quantity
R.	Right
SAE	Society of Automotive Engineers
SCS	Service Check Signal
STD	Standard
SW	Switch
TDC	Top Dead Center
TP	Throttle Position
VST	Variable Speed Transmission
VTEC	Variable Valve Timing & Valve Lift Electronic Control

Bl	Black	G	Green	Br	Brown	Lg	Light green
Y	Yellow	R	Red	O	Orange	P	Pink
Bu	Blue	W	White	Lb	Light blue	Gr	Gray

# 1. SPECIFICATIONS

---

SERIAL NUMBER LOCATION .....	1-2	DIMENSIONAL DRAWINGS .....	1-5
SPECIFICATIONS .....	1-3	WIRING DIAGRAM .....	1-6

## SPECIFICATIONS

---

### SERIAL NUMBER LOCATION

The engine serial number is located on the cylinder block.

The frame serial number is located on the handle column.

Refer to these numbers when ordering parts and when making technical inquiries.

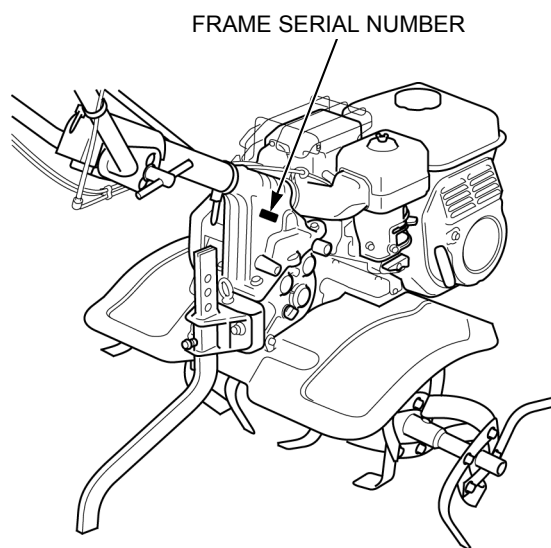
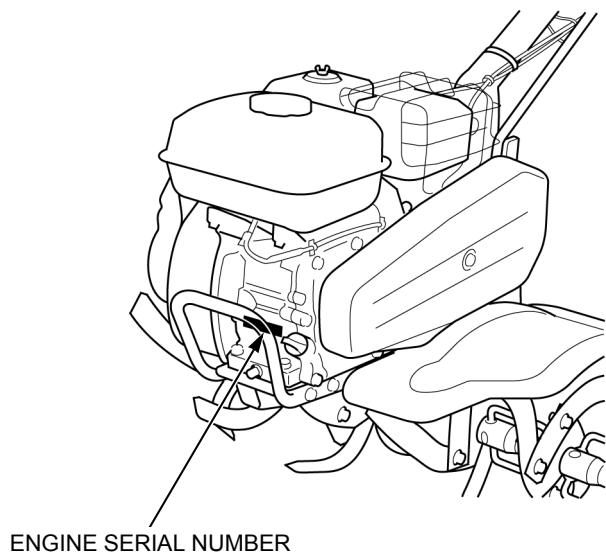

# SPECIFICATIONS

## DIMENSIONS AND WEIGHTS

Model	FJ500
Description code	FAAC
Type	French rotor
Type code	RD
Overall length*	1,340 mm (52.8 in)
Overall width	900 mm (35.4 in)
Overall height*	1,080 mm (42.5 in)
Minimum ground clearance	80 mm (3.1 in)
Dry weight**	55 kg (121 lbs)
Operating weight***	58 kg (128 lbs)

Each dimension shall be determined when tines with each rotor is on level surface with engine bed in a level position.

Each mass value when french rotor (11 kg, 24 lbs) is installed shall be given.

\*: Dimensions of overall length and overall height shall be determined when locating tightening position of handle pipe middle of movable range in vertical direction.

\*\* : Without oil and fuel.

\*\*\*: With oil (specified upper level) and fuel (fuel tank upper level).

## ENGINE

Model	GX160H1
Description code	GCAAH
Type	4-stroke, OHV, single cylinder, inclined by 25°
Total displacement	163 cm <sup>3</sup> (9.9 cu-in)
Bore and stroke	68.0 x 45.0 mm (2.68 x 1.77 in)
Max. horsepower	3.6 kW (4.9 PS)/3,600 min <sup>-1</sup> (rpm)
Max. torque	10.3 N·m (1.1 kgf·m, 8 lbf·ft)/2,500 min <sup>-1</sup> (rpm)
Compression ratio	8.5 : 1
Cooling system	Forced-air
Ignition system	Transistorized magneto ignition
Ignition timing	25° B.T.D.C.
Spark plug	BPR5ES (NGK), W16EPR-U (DENSO)
Carburetor	Horizontal type, butterfly valve
Air cleaner	Dual element type
Lubricating system	Splash
Engine oil capacity	0.58 liter (0.61 US qt, 0.51 Imp qt)
Recommended engine oil	SAE 10W-30 API service classification SE or higher
Starting system	Recoil
Stopping system	Ignition primary circuit ground
Fuel used	Unleaded gasoline with a pump octane rating 86 or higher
Fuel tank capacity	2.4 liters (0.63 US gal, 0.53 Imp gal)
P.T.O. shaft rotation	Counterclockwise (from P.T.O. side)
Breather system	Flat valve type

## SPECIFICATIONS

### FRAME

Model		FJ500
Type		French rotor
Type code		RD
Standard handle height (with rotor operation position)		1,050 mm (41.3 in)
Handle height adjustment		935 – 1,150 mm (36.8 – 45.3 in)
Rear hitch width		100 mm (3.9 in)
Rear hitch height		75 mm (3.0 in)
Tillage depth adjustment		Move drag bar up and down (5 height positions)
Tillage width	2 strand	350 mm (13.8 in)
	4 strand	630 mm (24.8 in)
	6 strand	900 mm (35.4 in)
Number of tines	2 strand	4 tines per rotor
	4 strand	8 tines per rotor
	6 strand	12 tines per rotor
Rotor assembly		O.D. 300 mm (11.8 in)
Engine to transmission mechanism		V-belt
V-belt		W400 SB-38
Clutch		Belt tension type
Clutch operation		Manual lever
Transmission lubrication		Oil bath
Transmission oil capacity		0.95 liter (1.00 US qt, 0.84 Imp qt)
Recommended transmission oil		SAE 10W-30 API service classification SE or higher
Transmission final gear ratio	1st	24.79
	2nd	17.46
	R	70.51
Rotor shaft speed *		1st: 79.5 min <sup>-1</sup> (rpm), 2nd: 112.9 min <sup>-1</sup> (rpm), R: 28.0 min <sup>-1</sup> (rpm)

\*: at engine speed 3,600 min<sup>-1</sup> (rpm)

DIMENSIONAL DRAWINGS

Unit: mm (in)

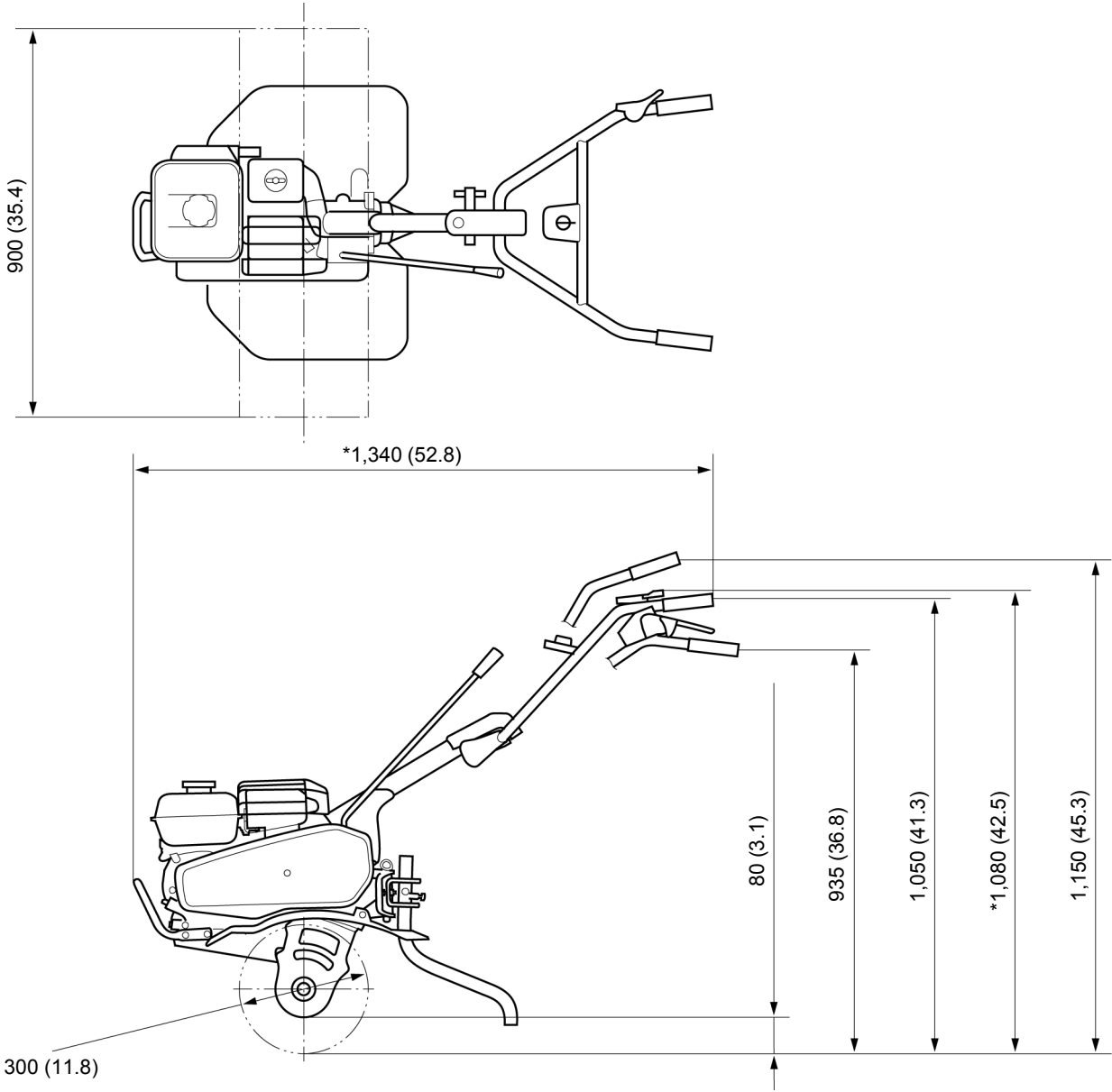

Each dimension shall be determined when tines with each rotor is on level surface with engine bed in a level position.

\*: Dimensions of overall length and overall height shall be determined when locating tightening position of handle pipe middle of movable range in vertical direction.

SPECIFICATIONS

WIRING DIAGRAM

Bl: BLACK  
G: GREEN

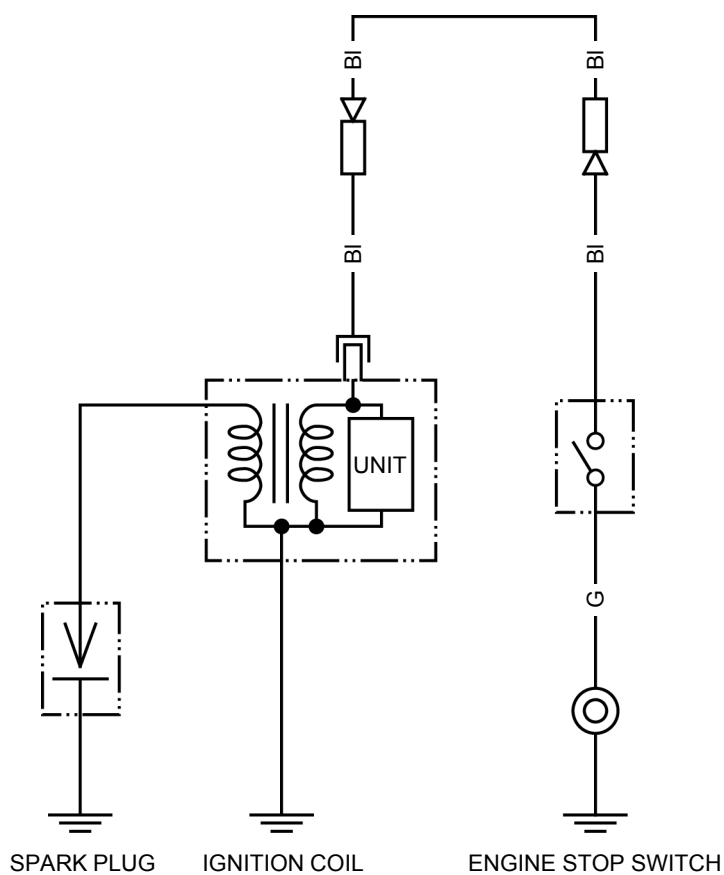

# 2. SERVICE INFORMATION

---

MAINTENANCE STANDARDS .....	2-2	TOOLS .....	2-5
TORQUE VALUES .....	2-3	CABLE/HARNESS ROUTING .....	2-7
LUBRICATION & SEAL POINT .....	2-4	TUBE ROUTING .....	2-8

## SERVICE INFORMATION

# MAINTENANCE STANDARDS

			Unit: mm (in)		
Part	Item		Standard	Service limit	
Engine	Idle speed		1,250 – 1,550 min <sup>-1</sup> (rpm)	–	
	Maximum engine speed (at no load)		3,800 $\begin{matrix} 0 \\ -200 \end{matrix}$ min <sup>-1</sup> (rpm)	–	
	Cylinder compression		0.59 MPa (6.0 kgf/cm <sup>2</sup> , 86 psi)/600 min <sup>-1</sup> (rpm)	–	
Cylinder	Sleeve I.D.		68.000 – 68.015 (2.6772 – 2.6778)	68.165 (2.6837)	
Cylinder head	Warpage		–	0.10 (0.004)	
Piston	Skirt O.D. at 10 mm (0.4 in) from bottom		67.965 – 67.985 (2.6758 – 2.6766)	67.845 (2.6711)	
	Piston-to-cylinder clearance		0.015 – 0.050 (0.0006 – 0.0020)	0.12 (0.005)	
	Piston pin bore I.D.		18.002 – 18.008 (0.7087 – 0.7090)	18.048 (0.7106)	
Piston pin	Pin O.D.		17.994 – 18.000 (0.7084 – 0.7087)	17.954 (0.7068)	
	Piston pin-to-piston pin bore clearance		0.002 – 0.014 (0.0001 – 0.0006)	0.06 (0.002)	
Piston rings	Ring side clearance	Top	0.035 – 0.070 (0.0014 – 0.0028)	0.15 (0.006)	
		Second	0.045 – 0.080 (0.0018 – 0.0032)	0.15 (0.006)	
	Ring end gap	Top	0.200 – 0.350 (0.0079 – 0.0138)	1.0 (0.04)	
		Second	0.350 – 0.500 (0.0138 – 0.0197)	1.0 (0.04)	
		Oil (side rail)	0.20 – 0.70 (0.008 – 0.028)	1.0 (0.04)	
	Ring width	Top	0.95 – 0.97 (0.037 – 0.038)	0.93 (0.037)	
Second		0.94 – 0.96 (0.037 – 0.038)	0.92 (0.036)		
Connecting rod	Small end I.D.		18.005 – 18.020 (0.7089 – 0.7094)	18.07 (0.711)	
	Big end I.D.		30.020 – 30.033 (1.1819 – 1.1824)	30.066 (1.1837)	
	Big end oil clearance		0.040 – 0.063 (0.0016 – 0.0025)	0.12 (0.005)	
	Big end side clearance		0.10 – 0.40 (0.004 – 0.016)	1.10 (0.043)	
Crankshaft	Crankpin O.D.		29.970 – 29.980 (1.1799 – 1.1803)	29.920 (1.1780)	
Valves	Valve clearance	IN	0.15 ± 0.02 (0.006 ± 0.001)	–	
		EX	0.20 ± 0.02 (0.008 ± 0.001)	–	
	Valve stem O.D.	IN	5.468 – 5.480 (0.2153 – 0.2157)	5.318 (0.2094)	
		EX	5.425 – 5.440 (0.2136 – 0.2142)	5.275 (0.2077)	
	Guide-to-stem clearance	IN	0.020 – 0.044 (0.0008 – 0.0017)	0.10 (0.004)	
		EX	0.060 – 0.087 (0.0024 – 0.0034)	0.12 (0.005)	
	Valve guide I.D.	IN/EX	5.500 – 5.512 (0.2165 – 0.2170)	5.572 (0.2194)	
	Valve seat width			0.7 – 0.9 (0.03 – 0.04)	2.0 (0.08)
	Valve spring free length			30.5 (1.20)	29.0 (1.14)
Valve spring perpendicularity			–	1.5°	
Camshaft	Camshaft O.D.		13.966 – 13.984 (0.5498 – 0.5506)	13.916 (0.5479)	
	Cam height	IN	27.500 – 27.900 (1.0827 – 1.0984)	27.45 (1.081)	
		EX	27.547 – 27.947 (1.0845 – 1.1003)	27.50 (1.083)	
Cylinder block	Camshaft holder I.D.		14.000 – 14.018 (0.5512 – 0.5519)	14.048 (0.5531)	
Crankcase cover	Camshaft holder I.D.		14.000 – 14.018 (0.5512 – 0.5519)	14.048 (0.5531)	
Spark plug	Gap		0.70 – 0.80 (0.028 – 0.031)	–	
Spark plug cap	Resistance		7.5 – 12.5 kΩ	–	
Ignition coil	Resistance	Primary side	0.81 – 0.99 Ω	–	
		Secondary side	5.85 – 7.15 kΩ	–	
	Air gap			0.20 – 0.60 (0.008 – 0.024)	–
Carburetor	Main jet		# 68	–	
	Float level height		3.4 (0.13)	–	
	Pilot screw opening		No adjustment	–	

**TORQUE VALUES****ENGINE TORQUE VALUES**

Item	Tread Dia.	Torque values			Remarks
	mm	N·m	kgf·m	lbf·ft	
Cylinder head bolt	M8 x 1.25	24	2.4	18	Apply engine oil to the bolt threads and seating surface.
Rocker arm pivot bolt	M8 x 1.25	24	2.4	18	
Rocker arm pivot lock nut	M6 x 0.5	10	1.0	7	
Crankcase cover bolt	M8 x 1.25	24	2.4	18	
Engine oil drain bolt	M10 x 1.25	18	1.8	13	
Connecting rod bolt	M7 x 1.0	12	1.2	9	Apply engine oil to the bolt threads and seating surface.
Spark plug	M14 x 1.25	18	1.8	13	
Flywheel nut	M14 x 1.5	75	7.6	55	Apply engine oil to the nut threads and seating surface.
Fuel tank bolt	M6 x 1.0	10	1.0	7	
Fuel tank nut	M6 x 1.0	10	1.0	7	
Fuel filter joint	M10 x 1.25	2	0.2	1.5	
Air cleaner elbow nut	M6 x 1.0	9	0.9	6.6	
Hose band screw	M4 x 0.7	–	–	–	See page 5-4
Muffler hex nut	M8 x 1.25	24	2.4	18	
Muffler deflector/guide mounting screw	M4 x 1.5	2	0.2	1.5	
Tail pipe screw	M5 x 0.8	3	0.3	2.2	
Muffler protector screw	M5 x 0.8	3	0.3	2.2	
Governor arm nut	M6 x 1.0	3	0.3	2.2	See page 6-3
Sediment cup	–	4.5	0.5	3.3	
Fuel valve lever screw	M3 x 0.5	0.7	0.07	0.5	Apply LOCTITE® 271 or equivalent to the threads (page 5-8).
Valve cover screw	M3 x 0.5	0.8	0.08	0.6	
Float chamber screw	M5 x 0.8	2.5	0.3	1.8	
Stop screw	M3 x 0.5	0.7	0.07	0.5	
Baffle screw	M3 x 0.5	0.8	0.08	0.6	

**FRAME TORQUE VALUES**

Item	Tread Dia.	Torque values			Remarks
	mm	N·m	kgf·m	lbf·ft	
Belt cover stay bolt/washer	M6 x 1.0	6	0.6	4.4	
Drive pulley bolt	M8 x 1.25	26.5	2.7	20	
Shift fork hex bolt	M6 x 1.0	10	1.0	7	
Cable guide screw	M5 x 1.5	3	0.3	2.2	
Handle column cover screw	M5 x 1.5	3	0.3	2.2	
Engine stop switch cover screw	M5 x 1.75	3	0.3	2.2	
Rotor nut	M8 x 1.25	26.5	2.7	20	

## SERVICE INFORMATION

### STANDARD TORQUE VALUES

Item	Tread Dia.	Torque values			Remarks
		N·m	kgf·m	lbf·ft	
Screw	4 mm	2	0.2	1.5	
	5 mm	4	0.4	2.9	
	6 mm	9	0.9	6.6	
Bolt and nut	5 mm	5	0.5	3.6	
	6 mm	10	1.0	7	
	8 mm	22	2.2	16	
	10 mm	34	3.5	25	
	12 mm	54	5.5	40	
Flange bolt and nut	6 mm	12	1.2	9	
	8 mm	27	2.8	20	
	10 mm	39	4.0	29	
	12 mm	59	6.0	44	
SH (Small head) flange bolt	6 mm	9	0.9	6.6	
CT (Cutting threads) flange bolt (Retightening)	6 mm	10	1.0	7	

## LUBRICATION & SEAL POINT







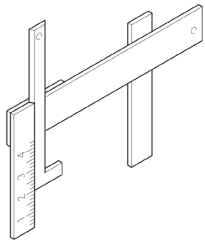

### ENGINE

Material	Location	Remarks
Engine oil	Crankpin and gears	
	Piston outer surface	
	Piston ring whole surface	
	Piston pin whole surface	
	Cylinder block inner surface	
	Connecting rod big and small end	
	Connecting rod bolt threads and seating surface	
	Camshaft cam profile and journal	
	Valve lifter stem, stem end and slipper surface	
	Valve stem sliding surface and stem end	
	Rocker arm tappet surface and pivot	
	Rocker arm pivot threads and pivot	
	Flywheel nut threads and seating surface	
	Cylinder head bolt threads and seating surface	
	Governor weight holder gear and sliding surface	
Governor shaft journal		
Governor arm shaft journal		
Each O-ring whole surface		
Molybdenum disulfide oil (a mixture of 1/2 engine oil and 1/2 molybdenum disulfide grease)	Camshaft cam profile	When new camshaft
Multi-purpose grease	Recoil starter cover boss	
	Recoil starter friction spring whole surface	
Silicone grease	Fuel valve groove	See page 5-8
	Fuel valve cover sliding surface	See page 5-8
LOCTITE® 271 or equivalent	Fuel valve lever screw threads	See page 5-8
Daphne Eponex No.2 or equivalent	Each oil seal lips	

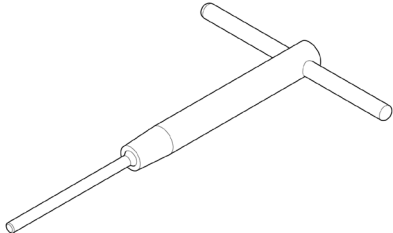
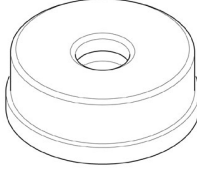

**FRAME**

Material	Location	Remarks
Transmission oil	Transmission oil filler cap O-ring	
Shell Alvania grease RA or equivalent	Pin (6 x 21 mm) clutch lever plate sliding surface	
	Exchange pin (8 x 39 mm) clutch lever sliding surface	
	Pin (5 x 18 mm) clutch lever plate sliding surface	
	Pin (5 x 36 mm) sliding surface	
	Change lever holder change lever sliding surface	
	Handle column pivot change lever holder sliding surface	
	Tension arm shaft tension arm sliding surface	
	Throttle lever control plate sliding surface	
ThreeBond® 1530C or equivalent	Change lever grip inside	
	Handle grip inside	

**TOOLS**

<p>Float level gauge 07401-0010000</p> 	<p>Seat cutter, 27.5 mm (45° IN) 07780-0010200</p> 	<p>Seat cutter, 24.5 mm (45° EX) 07780-0010100</p> 
<p>Flat cutter, 28 mm (32° IN) 07780-0012100</p> 	<p>Flat cutter, 25 mm (32° EX) 07780-0012000</p> 	<p>Interior cutter, 30 mm (60° IN/EX) 07780-0014000</p> 
<p>Cutter holder 5.5 mm 07781-0010101</p> 	<p>Attachment, 52 x 55 mm 07746-0010400</p> 	<p>Attachment, 37 x 40 mm 07746-0010200</p> 

## SERVICE INFORMATION

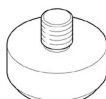
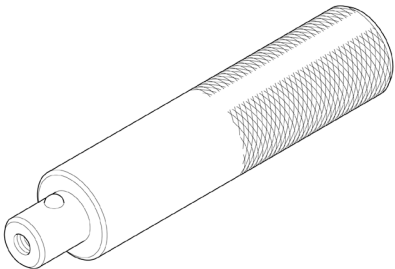
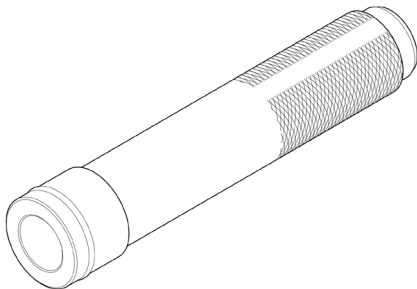
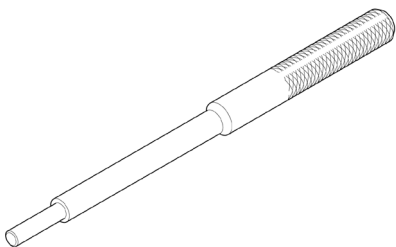
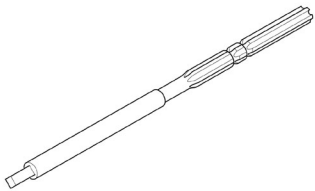
<p>Pilot, 22 mm 07746-0041000</p> 	<p>Pilot, 25 mm 07746-0040600</p> 	<p>Pilot, 28 mm 07746-0041100</p> 
<p>Driver 07749-0010000</p> 	<p>Driver, 22 mm I.D. 07746-0020100</p> 	<p>Valve guide driver, 5.5 mm 07742-0010100</p> 
<p>Valve guide reamer, 5.510 mm 07984-2000001</p> 		

# CABLE/HARNESS ROUTING

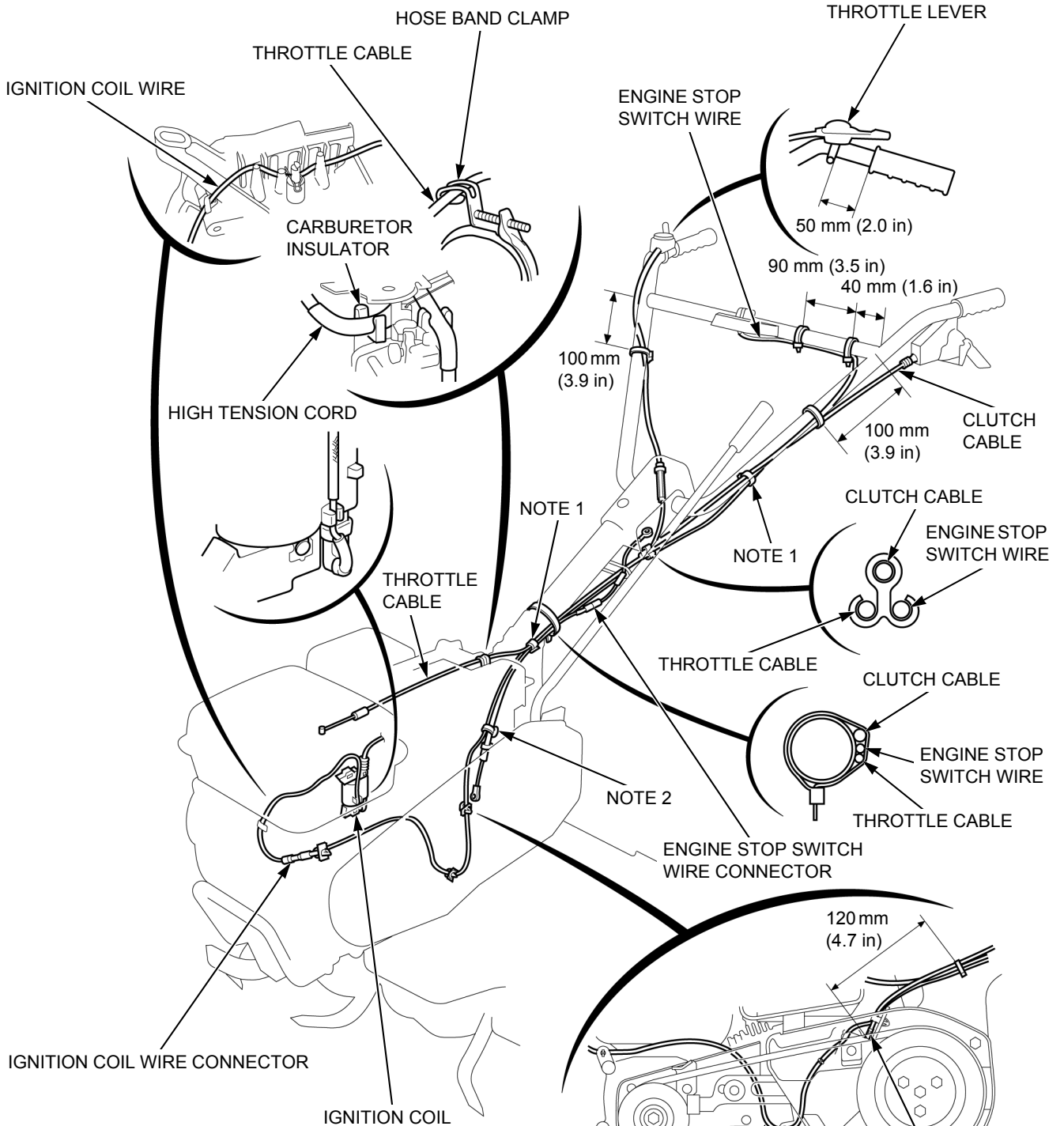

Cut the end of the bands as shown.

NOTE 1:

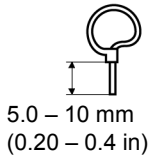

NOTE 2:

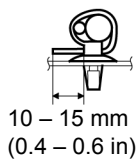

TUBE ROUTING

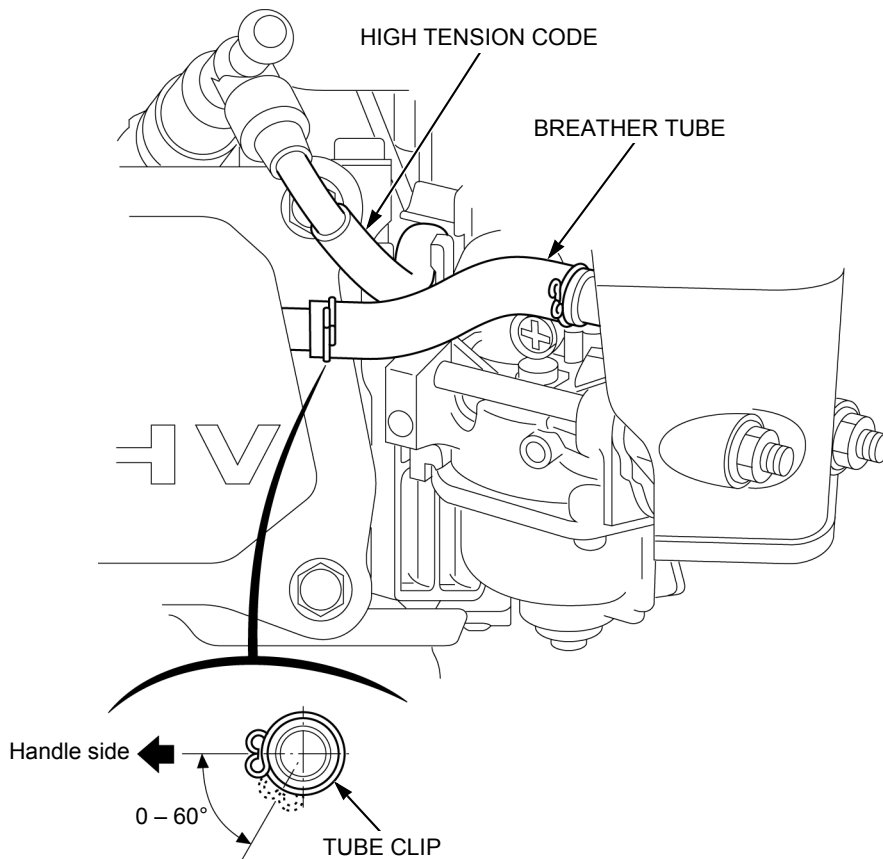
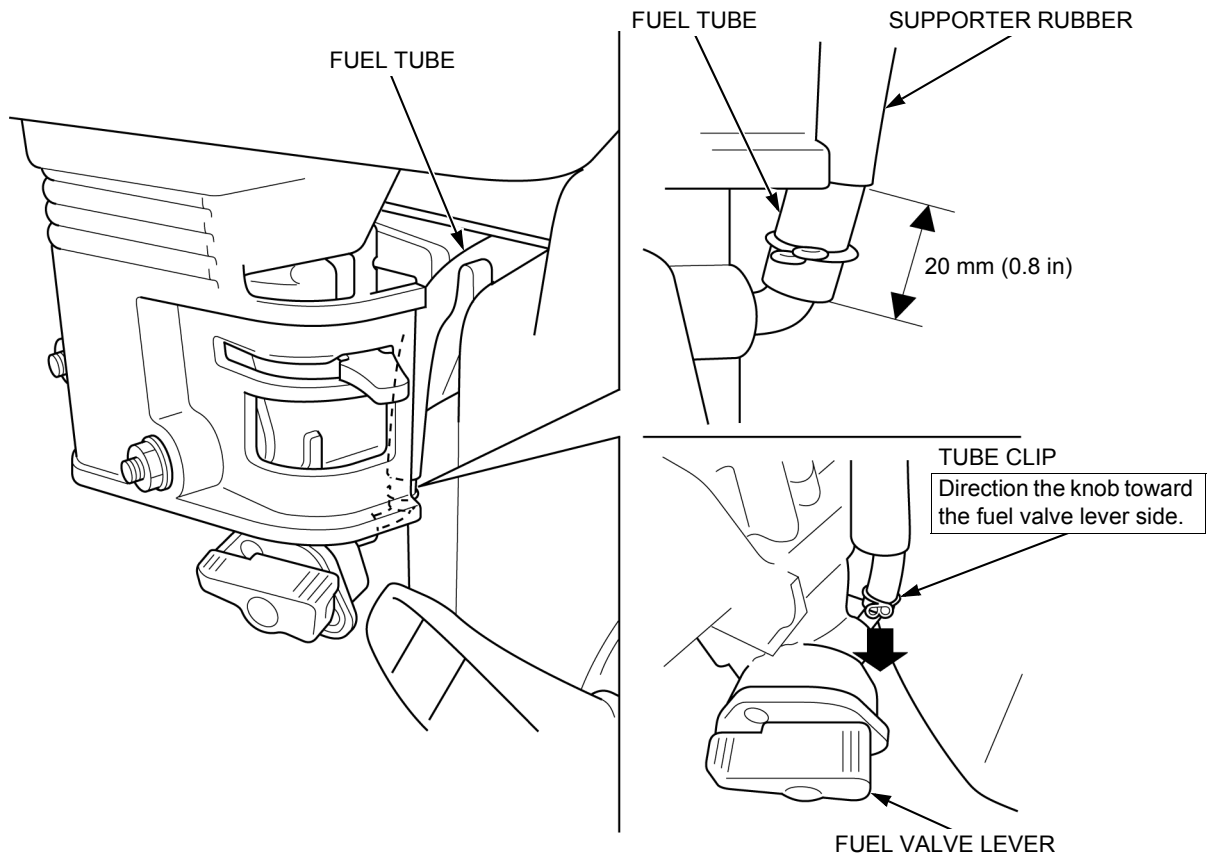

MAINTENANCE SCHEDULE.....	3-2	LUBRICATION.....	3-11
ENGINE OIL LEVEL CHECK.....	3-3	ENGINE IDLE SPEED CHECK/ ADJUSTMENT.....	3-11
ENGINE OIL CHANGE.....	3-4	SPARK PLUG INSPECTION/ADJUSTMENT/ REPLACEMENT.....	3-12
AIR CLEANER CHECK/CLEANING/ REPLACEMENT.....	3-5	THROTTLE CABLE CHECK/ ADJUSTMENT.....	3-13
NUTS, BOLTS, FASTENERS.....	3-6	VALVE CLEARANCE CHECK/ ADJUSTMENT.....	3-13
CLUTCH CABLE CHECK/ADJUSTMENT....	3-6	COMBUSTION CHAMBER CLEANING.....	3-14
BELT CHECK/ADJUSTMENT.....	3-7	FUEL TANK AND FILTER CLEANING.....	3-15
TRANSMISSION OIL LEVEL CHECK.....	3-9	FUEL TUBE INSPECTION.....	3-15
SEDIMENT CUP CLEANING.....	3-10		

## MAINTENANCE

# MAINTENANCE SCHEDULE

ITEM		REGULAR SERVICE PERIOD (1) Perform at every indicated month or operating hour interval, whichever comes first.						Refer to page
		After storage	Each use	First month or 20 hrs.	Every 3 months or 50 hrs.	Every 6 months or 100 hrs.	Every year or 300 hrs.	
Engine oil	Check-Level		○					3-3
	Change	○		○		○		3-4
Air cleaner	Check		○					3-5
	Clean				○ (2)			3-5
	Replace						○	3-5
Tiller outside	Check		○					-
Throttle lever function	Check		○					-
Bolts and nuts tightness	Check		○					3-6
Wiring and cables	Check		○					2-7
Engine operation	Check		○					-
Recoil starter cover	Check-Clean		○					8-2
Clutch lever function	Check-Clean		○					-
	Grease lubricate	○ (3)						14-4
Transmission oil	Check-Level	○		○			○	3-9
Sediment cup	Clean					○		3-10
Grease application	Grease lubricate	○						3-11
Spark plug	Check-Adjust					○		3-12
	Replace						○	3-12
Throttle cable	Check-Adjust						○	3-13
Engine idle speed	Check-Adjust						○	3-11
Clutch cable	Check-Adjust			○		○		3-6
Drive belt	Check-Adjust			○ (4)		○ (4)		3-7
Valve clearance	Check-Adjust						○	3-13
Combustion chamber	Clean	After every 500 hrs.						3-14
Fuel tank and filter	Clean	○				○		3-15
Fuel tube	Check	Every 2 years (Replace if necessary)						3-15

(1) For commercial use, log hours of operation to determine proper maintenance intervals.

(2) Service every 10 operating hours or every day when used in dusty areas.

(3) Apply grease to the pin part of the clutch lever fulcrum and so on for prevention of rust when you keep it for a long time (more than 30 days).

(4) Check that there are no cracks and abnormal wear in the belt, and replace it if necessary.

# ENGINE OIL LEVEL CHECK

## NOTICE

- Check the engine oil level with the engine stopped.

Place the tiller on a firm level surface with the rotor set on the ground so that the engine becomes level.

Remove the oil filler cap/dipstick [1] and wipe the dipstick clean.

Insert the oil filler cap/dipstick in the oil filler neck, but do not screw it in.

Remove the oil filler cap/dipstick and check the oil level.

If the oil level is near or below the lower level [2] on the dipstick, fill with the recommended engine oil to the upper level (top of the oil filler neck) [3].

### RECOMMENDED ENGINE OIL:

**SAE 10W-30**

**API service classification SE or higher**

Oil is a major factor affecting performance and service life. Use 4-stroke automotive detergent oil.

SAE 10W-30 is recommended for general use. Other viscosities shown in the chart may be used when the average temperature in your area is within the recommended range.

Check that the O-ring [4] is in good condition, replace it if necessary.

Apply engine oil to the O-ring.

Reinstall the oil filler cap/dipstick securely.

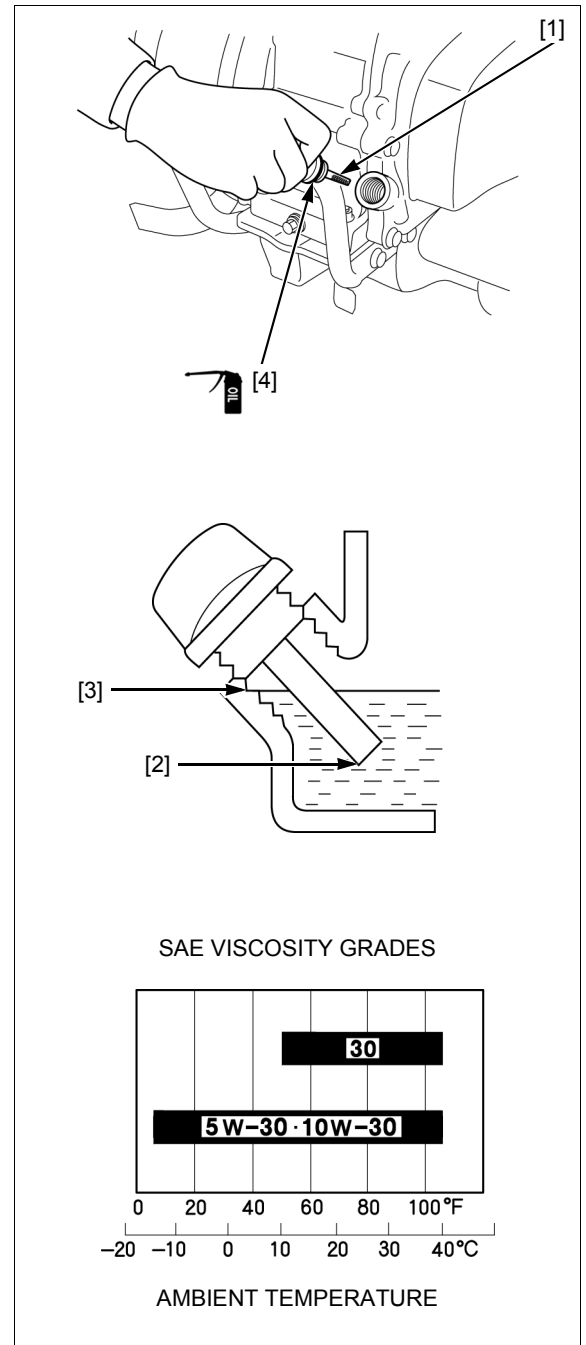

## MAINTENANCE

# ENGINE OIL CHANGE

### NOTE:

- Drain the used engine oil while the engine is warm.  
Warm oil drains quickly and completely.

Place a suitable container [1] under the engine oil drain bolt (10 x 15 mm) [2].

Remove the oil filler cap/dipstick [3], drain bolt, sealing washer (10 mm) [4] and drain the engine oil into the suitable container.

Please dispose of used engine oil in a manner that is compatible with the environment. We suggest you take used oil in a sealed container to your local recycling center or service station for reclamation. Do not throw it in the trash, pour it on the ground, or pour it down a drain.

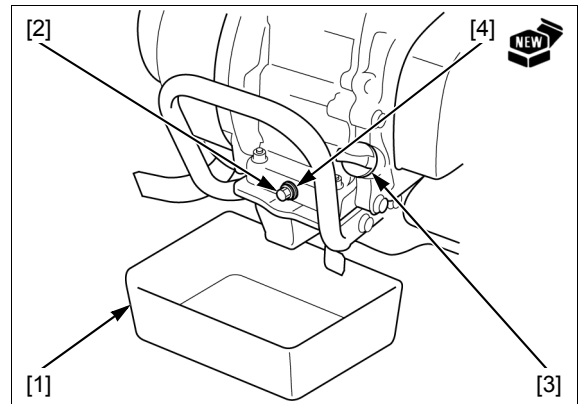

## ⚠ CAUTION

Used engine oil contains substances that have been identified as carcinogenic. If repeatedly left in contact with the skin for prolonged periods, it may cause skin cancer. Wash your hands thoroughly with soap and water as soon as possible after contact with used engine oil.

Install the drain bolt and new sealing washer. Tighten the drain bolt to the specified torque.

**TORQUE: 18 N·m (1.8 kgf·m, 13 lbf·ft)**

With the tiller on a level surface, fill the recommended engine oil to the upper level (page 3-3).

### ENGINE OIL CAPACITY:

**0.58 liter (0.61 US qt, 0.51 Imp qt)**

Install the oil filler cap/dipstick.

Recheck the engine oil level (page 3-3).

Make sure there are no engine oil leaks.

# AIR CLEANER CHECK/CLEANING/ REPLACEMENT

**NOTE:**

- A dirty air cleaner element will restrict air flow to the carburetor, reducing engine performance. If the engine is operated in dusty areas, clean the air cleaner element more often than specified in the "MAINTENANCE SCHEDULE" (page 3-2).

**NOTICE**

- *Operating the engine without an air cleaner element or with a damaged air cleaner element, will allow dirt to enter the engine, causing rapid engine wear.*

Remove the air cleaner cover nut [1].

Remove the throttle cable [2] from the hose band clamp [3].

Loosen the hose band screw (4 x 30 mm) [4] and disconnect the air cleaner hose [5], and then remove the air cleaner cover [6].

Remove the wing nut [7], foam element [8] and paper element [9].

Remove the elbow packing [10] and cover packing [11] from the air cleaner elbow [12].

Carefully check both elements for holes or tears and replace if damaged.

Check the air cleaner elbow packing and cover packing for deterioration or damage.

Wipe dirt from the inside of the air cleaner cover, air cleaner hose and air cleaner elbow with a moist rag. Be careful to prevent dirt from entering the air cleaner elbow that leading to the carburetor.

Clean the foam element [1] in warm soapy water, rinse and allow to dry thoroughly, or clean with a high flush point solvent [2] and allow to dry thoroughly.

Dip the form element in clean engine oil [3] and squeeze out all the excess oil.

Excess oil will restrict air flow through the form element and may cause the engine to smoke at startup.

Tap the paper element [1] several times on a hard surface to remove dirt, or blow compressed air (not exceeding 207 kPa, 2.1 kgf/cm<sup>2</sup>, 30 psi) through the paper element from the inside.

Never try to brush off dirt; brushing will force dirt into the paper fibers.

Assemble the air cleaner in the reverse order of disassembly.

Tighten the hose band screw (4 x 30 mm) to the specified distance (page 5-4).

**NOTE:**

- After assembly, clamp the throttle cable with hose band clamp (page 5-4).

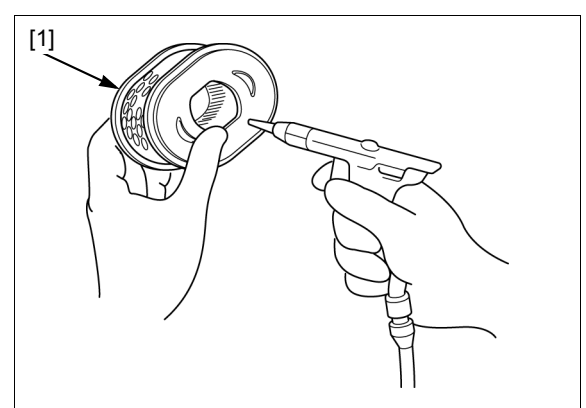
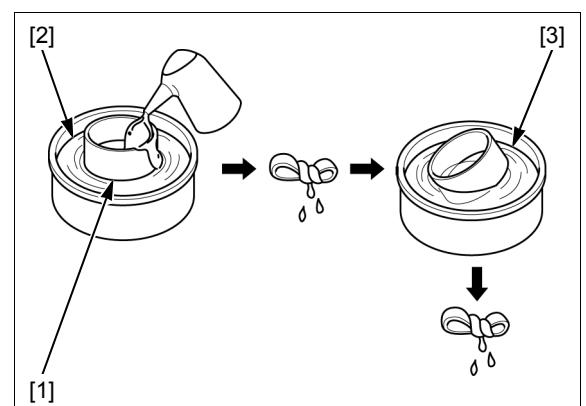
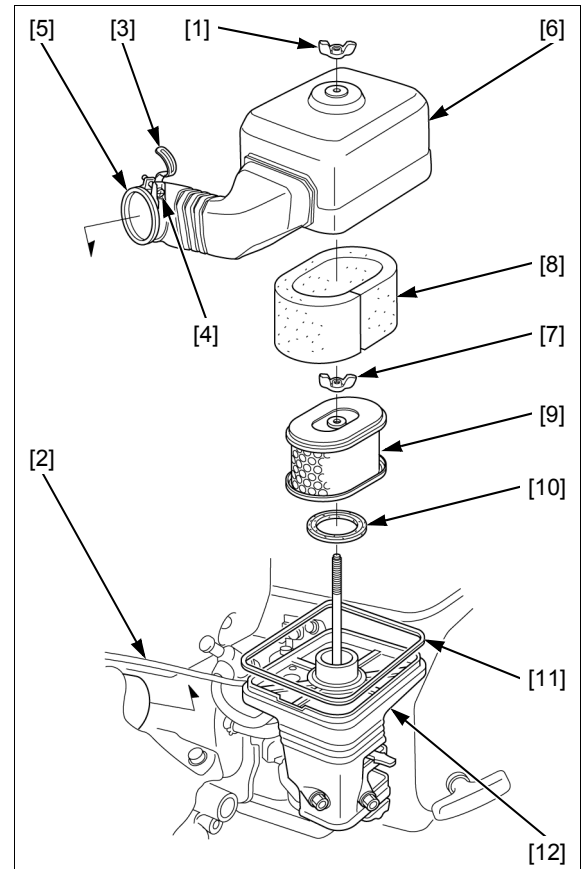

## MAINTENANCE

### NUTS, BOLTS, FASTENERS

Check that all chassis nuts and bolts are tighten to their correct torque values (page 2-3).

Check that all split pins, safety clips, hose clamps and cable stays are in place and properly secured.

### CLUTCH CABLE CHECK/ADJUSTMENT

#### CHECK

Check for any deterioration or damage to the clutch cable [1].

Squeeze the clutch lever [2] several times.

If there is a problem, adjust the clutch cable (page 3-6).

If there is a problem yet, disassemble the clutch lever and clean the parts (page 14-4).

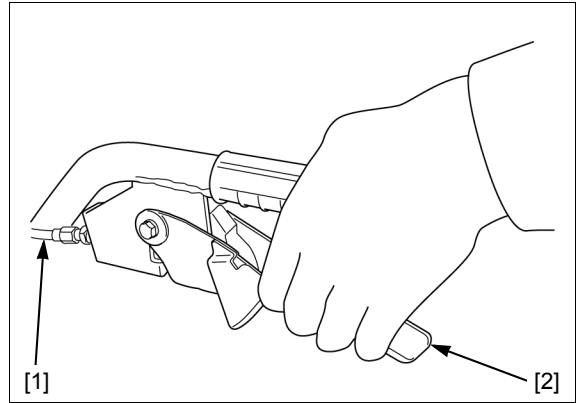

#### ADJUSTMENT

Remove the belt cover (page 11-2).

Set the V-belt [1] so that the V-belt joint area [2] is not located between the drive pulley [3] and driven pulley [4].

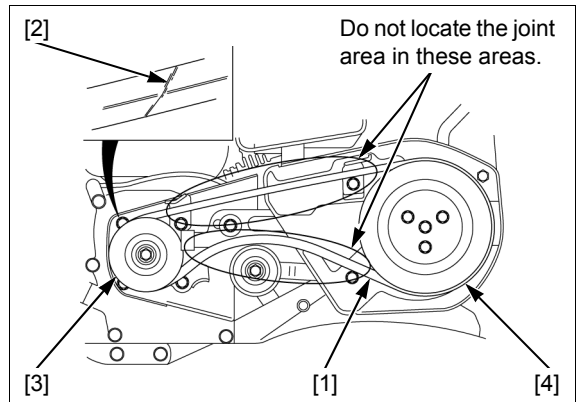

Squeeze the clutch lever [1] ten times.

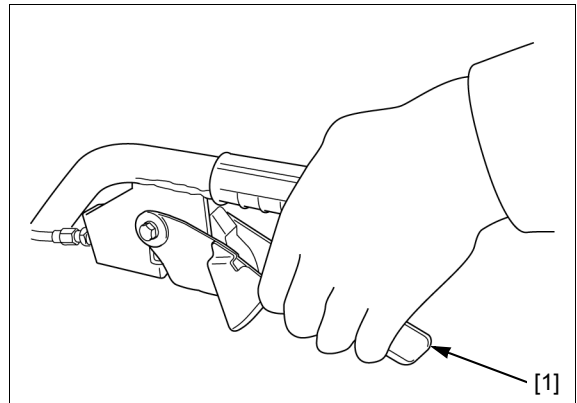

Turn the clutch stopper pin [1] counterclockwise with the torque wrench [2] and read the maximum torque until the clutch lever is fully seated.

Read the torque wrench.

**STANDARD TORQUE VALUE:**

**6.6 – 7.2 N·m (0.67 – 0.73 kgf·m, 4.9 – 5.3 lbf·ft)**

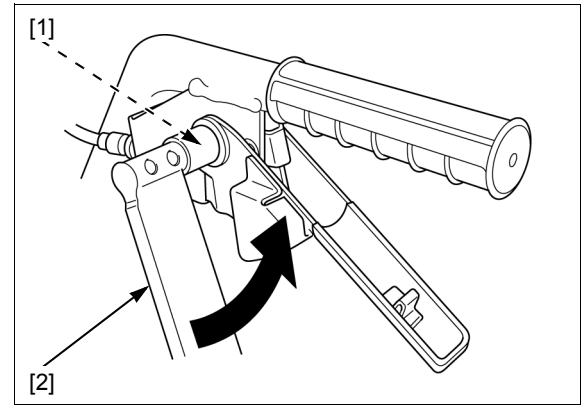

If the torque is out of standard value, loosen the lock nut [1] and adjust the torque by turning the adjusting bolt [2] as following torque table.

	<b>Turn in</b>	<b>Turn out</b>
1/2	-0.5 N·m (0.1 kgf·m, 0.4 lbf·ft)	+0.5 N·m (0.1 kgf·m, 0.4 lbf·ft)
1	-1.0 N·m (0.1 kgf·m, 0.7 lbf·ft)	+1.0 N·m (0.1 kgf·m, 0.7 lbf·ft)
3/2	-1.5 N·m (0.2 kgf·m, 1.1 lbf·ft)	+1.5 N·m (0.2 kgf·m, 1.1 lbf·ft)
2	-2.0 N·m (0.2 kgf·m, 1.5 lbf·ft)	+2.0 N·m (0.2 kgf·m, 1.5 lbf·ft)

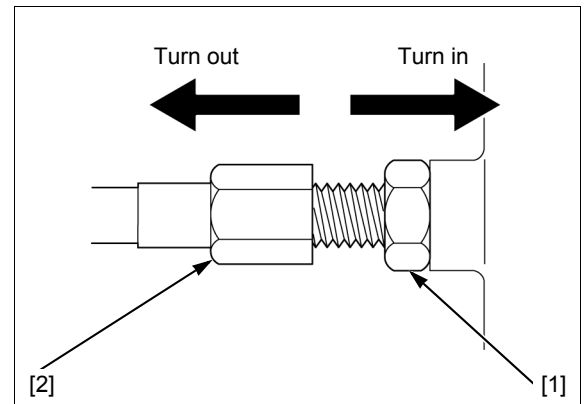

Squeeze the clutch lever ten times and recheck the lever torque.

After adjustment, tighten the lock nut.

## **BELT CHECK/ADJUSTMENT**

### **CHECK**

Remove the belt cover (page 11-2).

Check that there is no crack and abnormal wear-out in the belt, and replace if it is abnormal (page 11-2).

### **BELT TENSION ADJUSTMENT**

Remove the belt cover (page 11-2).

Squeeze the V-belt [1] with force more than six times as shown.

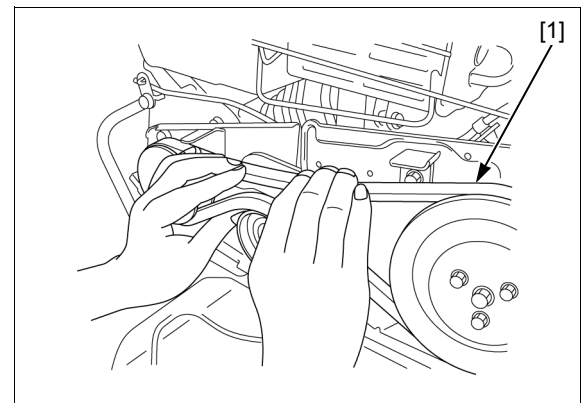

## MAINTENANCE

With the clutch engaged, measure the distance L [1] between the upper and lower belt runs at the belt tensioner.

**SPECIFIED DISTANCE L: 43 – 49 mm (1.7 – 1.9 in)**

If the measured distance L is within specified distance L, adjust the belt stopper (page 3-9).

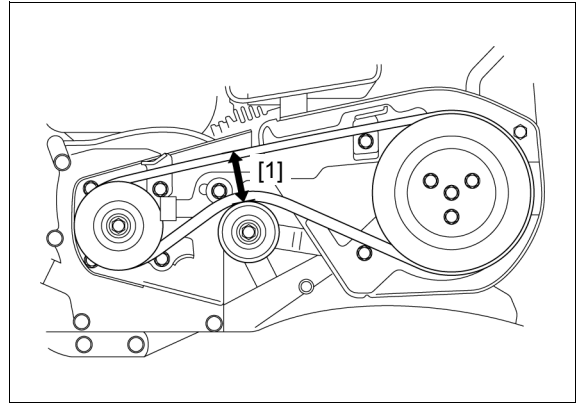

If the measured distance L is out of specified distance L, adjust the belt tension.

Loosen four engine mounting bolts (8 x 35 mm)/nuts (8 mm) [1].

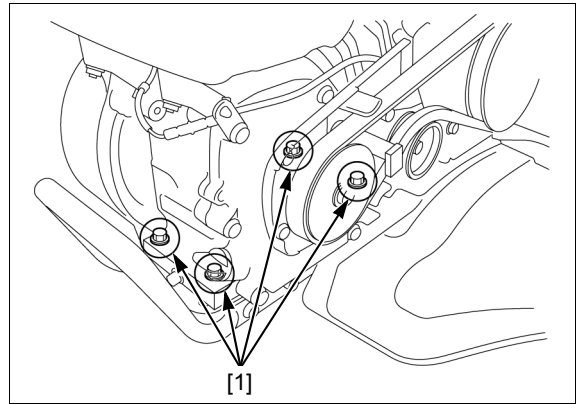

Loosen the engine stay bolt (8 x 20 mm) [1] and adjust the distance  $\ell$  [2] by moving the engine back or forward until the correct distance L is obtained.

Distance $\ell$	Distance L
-2.0 mm (0.08 in)	-4.0 mm (0.16 in)
-1.0 mm (0.04 in)	-2.0 mm (0.08 in)
+1.0 mm (0.04 in)	+2.0 mm (0.08 in)
+2.0 mm (0.08 in)	+4.0 mm (0.16 in)

Recheck the distance L.

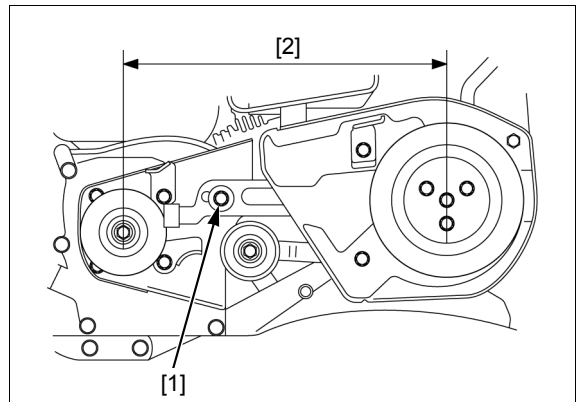

After adjusting the belt tension, check the drive pulley [1] and driven pulley [2] for proper alignment as shown.

If the pulleys are not aligned, check the pulley bolts for tightness and the pulleys for possible distortion.

Tighten the engine stay bolt and engine mounting bolts securely.

Adjust the belt stopper clearance (page 3-9).

After belt stopper clearance adjustment, adjust the clutch lever torque (page 3-6).

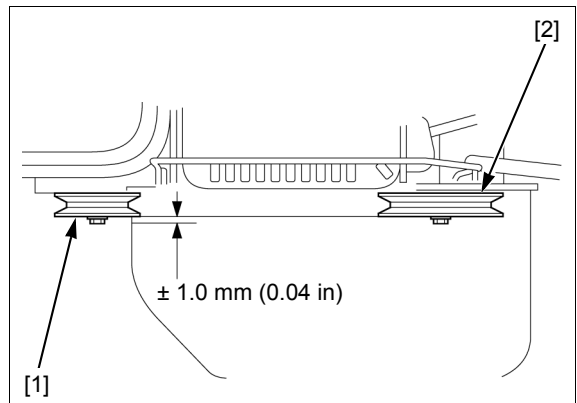

## BELT STOPPER ADJUSTMENT

Remove the belt cover (page 11-2).

With the clutch engaged, measure the clearance between the V-belt [1] and three belt stoppers [2].

### STANDARD CLEARANCE:

- A: 1.0 – 3.0 mm (0.04 – 0.12 in)
- B: 7.0 – 10.0 mm (0.28 – 0.39 in)
- C: 1.0 – 3.0 mm (0.04 – 0.12 in)

To adjust the clearance, loosen the upper belt stopper bolt (8 x 16 mm) [3], lower belt stopper bolt (8 x 16 mm) [4], belt stopper C bolt (6 x 12 mm) [5] and move the stoppers up or down as necessary and tighten the stopper bolts securely.

After adjusting the clearance, start the engine and then disengage the clutch and make sure that the V-belt is not being pulled by the drive pulley.

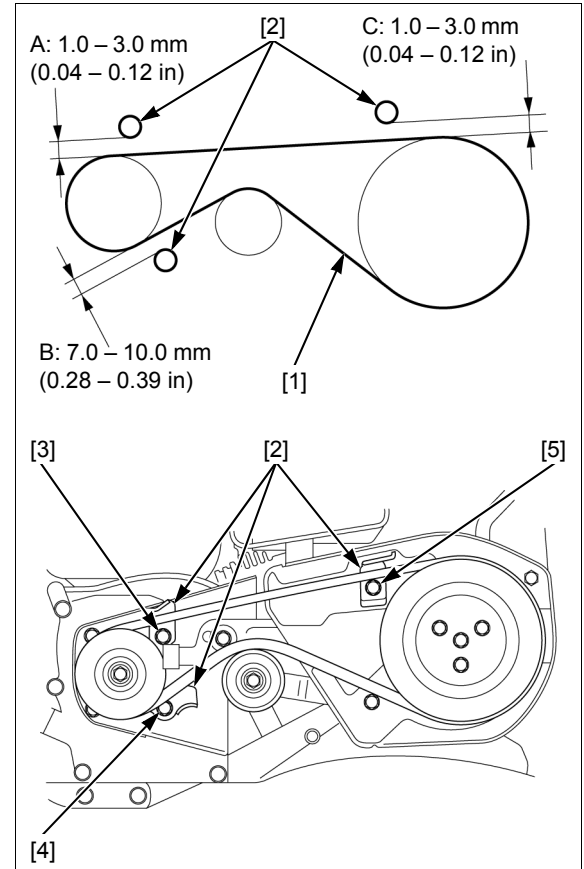

## TRANSMISSION OIL LEVEL CHECK

### NOTICE

- Check the transmission oil level with the engine stopped.

Place the tiller on a firm level surface with the rotor set on the ground so that the engine becomes level.

Remove the oil filler cap [1] and check the oil level is up to the lower edge [2] of the oil filler hole.

If the level is low, fill with the recommended transmission oil to the upper level (up to the lower edge of the oil filler hole).

### RECOMMENDED TRANSMISSION OIL:

- SAE 10W-30
- API service classification SE or higher

Check that the O-ring [3] is in good condition, replace it if necessary.

Apply transmission oil to the O-ring.

Reinstall and tighten the oil filler cap securely.

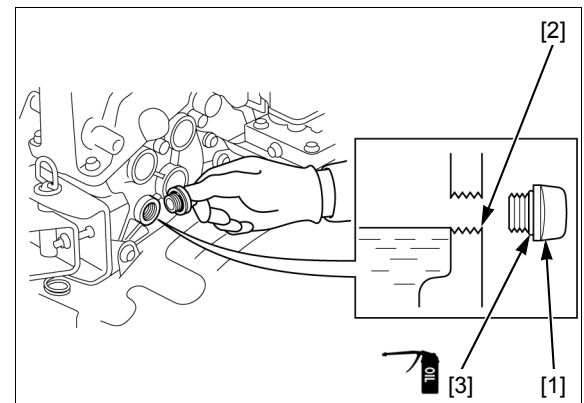

## SEDIMENT CUP CLEANING

### **⚠ WARNING**

Gasoline is highly flammable and explosive. You can be burned or seriously injured when handling fuel.

- Keep heat, sparks, and flame away.
- Handle fuel only outdoors.
- Wipe up spills immediately.

Turn the fuel valve lever [1] to the "DRAIN" position while pushing the stopper button [2] then drain the fuel into a suitable container.

Turn the fuel valve lever to the "OFF" position.

Remove the sediment cup [3] and O-ring [4].

NOTE:

- Be careful not to spill the fuel from the sediment cup.

Wash the sediment cup in non-flammable solvent and dry it thoroughly.

Place a new O-ring in the float chamber [5] and install the sediment cup.

Tighten the sediment cup to the specified torque.

**TORQUE: 4.5 N·m (0.5 kgf·m, 3.3 lbf·ft)**

Turn the fuel valve lever to the "ON" position and check for fuel leaks.

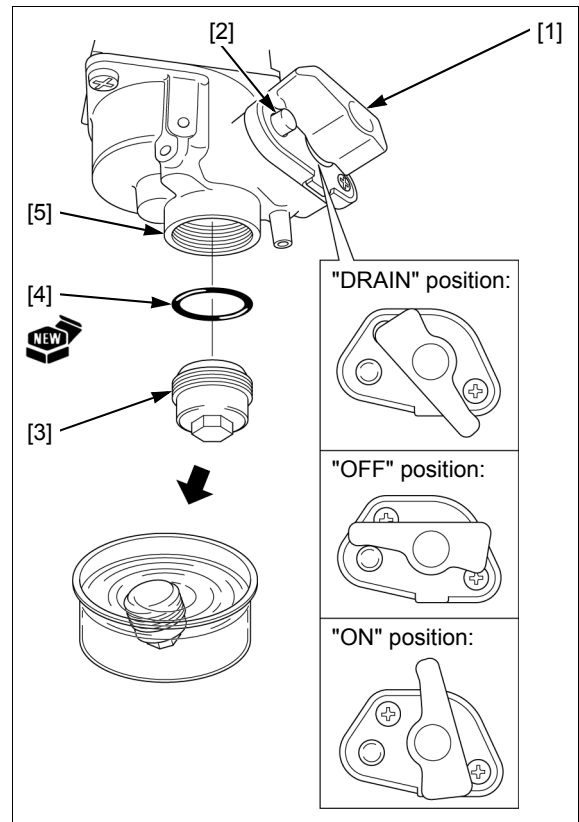

# LUBRICATION

Apply grease to the following parts:

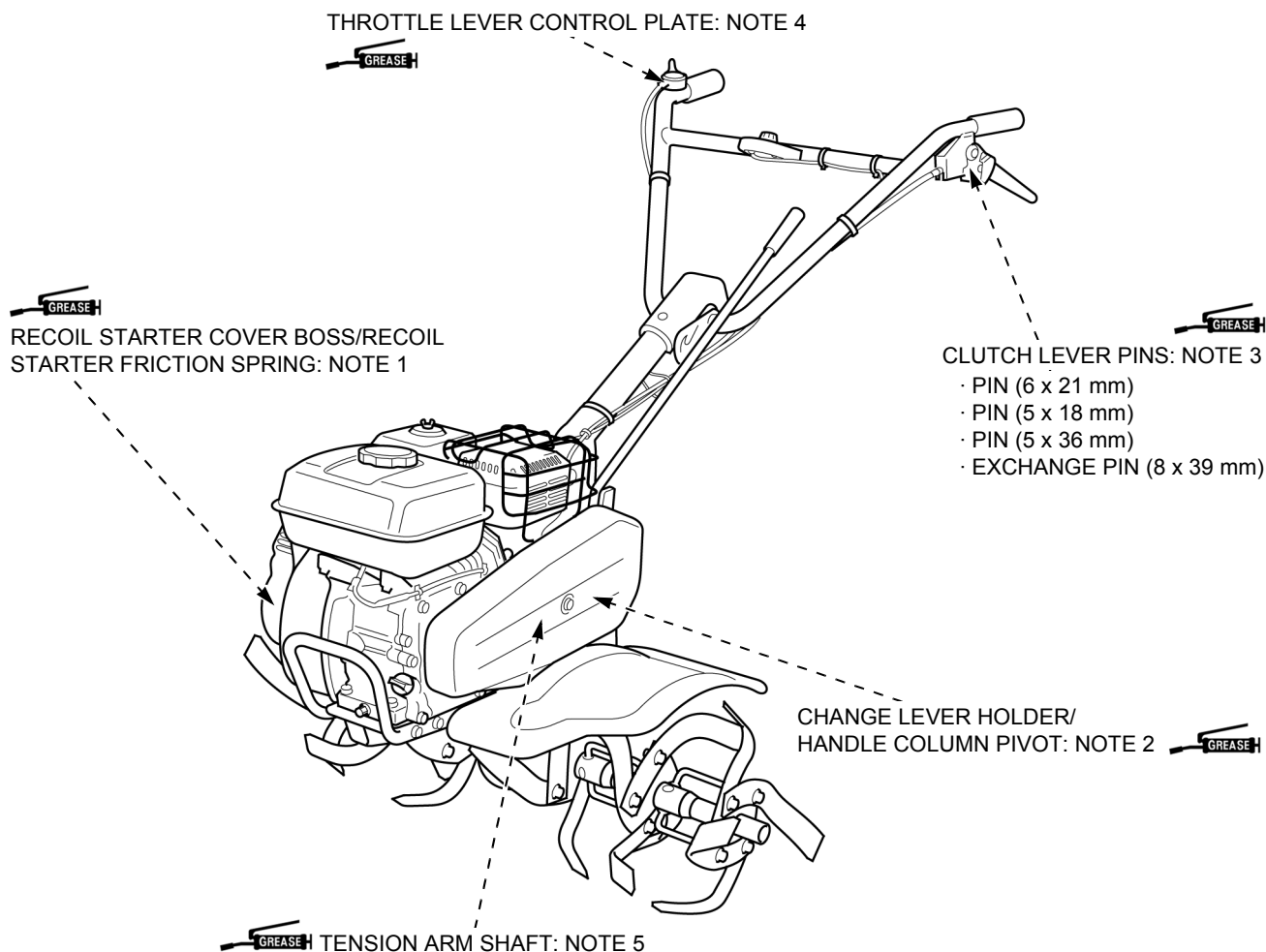

NOTE 1	RECOIL STARTER DISASSEMBLY/ASSEMBLY	page 8-3
NOTE 2	HANDLE COLUMN DISASSEMBLY/ASSEMBLY	page 14-3
NOTE 3	CLUTCH LEVER DISASSEMBLY/ASSEMBLY	page 14-4
NOTE 4	THROTTLE LEVER DISASSEMBLY/ASSEMBLY	page 14-5
NOTE 5	TRANSMISSION REMOVAL/INSTALLATION	page 15-7

## ENGINE IDLE SPEED CHECK/ADJUSTMENT

NOTE:

- Use a tachometer with graduations of 50 min<sup>-1</sup> (rpm) or smaller that will accurately indicate a 50 min<sup>-1</sup> (rpm) change.

Warm up the engine.

Stop the engine and connect a tachometer according to manufacture's operating instruction.

Start the engine and check the idle speed.

**IDLE SPEED: 1,250 – 1,550 min<sup>-1</sup> (rpm)**

If the idle speed is out of the specification, turn the throttle stop screw [1] to obtain the specified standard idle speed.

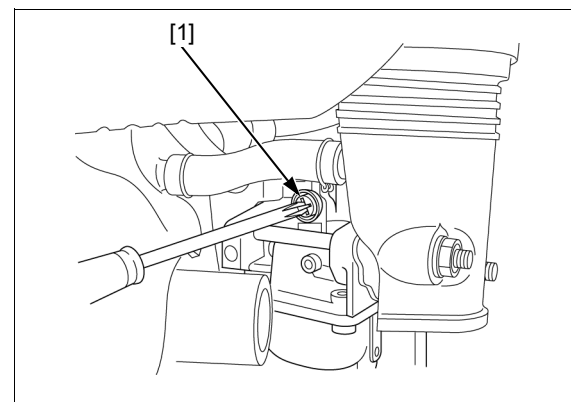

# SPARK PLUG INSPECTION/ ADJUSTMENT/REPLACEMENT

## ⚠ CAUTION

If the engine has been running, the engine will be very hot. Allow it to cool before proceeding.

- Clean any dirt from around the spark plug [1].
- Remove the spark plug cap [2].
- Remove the spark plug with a spark plug wrench.

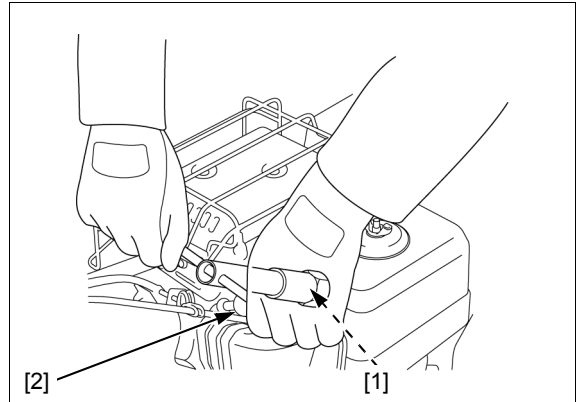

Visually inspect the spark plug. Replace the plug if the insulator [1] is cracked or chipped.

Remove carbon or other deposits with wire brush.

Check the sealing washer [2], center electrode [3] and side electrode [4] for damage.

## NOTICE

- An incorrect spark plug can cause engine damage. Use the recommended spark plug or an exact equivalent.
- Replace the spark plug if the sealing washer is damaged.

### RECOMMENDED SPARK PLUG: BPR5ES (NGK), W16EPR-U (DENSO)

Measure the plug gap with a thickness gauge. If the measurement is out of the specification, adjust by bending the side electrode.

**SPARK PLUG GAP: 0.70 – 0.80 mm (0.028 – 0.031 in)**

Install the spark plug finger tight to seat the washer, then tighten it to the specified torque.

**TORQUE: 18 N·m (1.8 kgf·m, 13 lbf·ft)**

## NOTICE

- A loose spark plug can become very hot and can damage the engine. Overtightening can damage the threads in the cylinder head.

Install the spark plug cap.

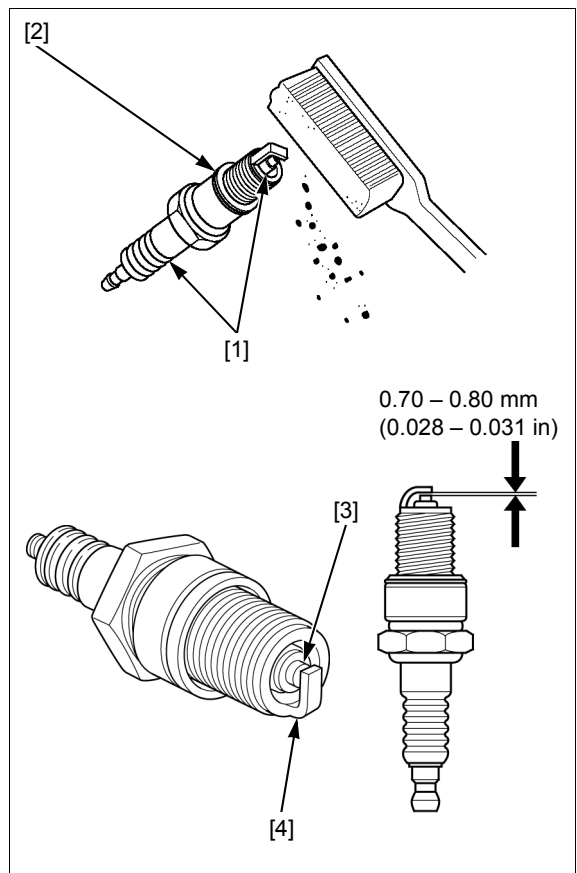

## THROTTLE CABLE CHECK/ ADJUSTMENT

Check for any deterioration or damage to the throttle cable [1].

Check the throttle lever [2] for smooth operation.

Measure the throttle lever freeplay at the lever tip.

**FREEPLAY: 5 – 10 mm (0.2 – 0.4 in)**

If the throttle lever freeplay is incorrect, loosen the lock nut [3] and turn the adjusting nut [4] in or out as required.

After adjustment, tighten the lock nut securely.

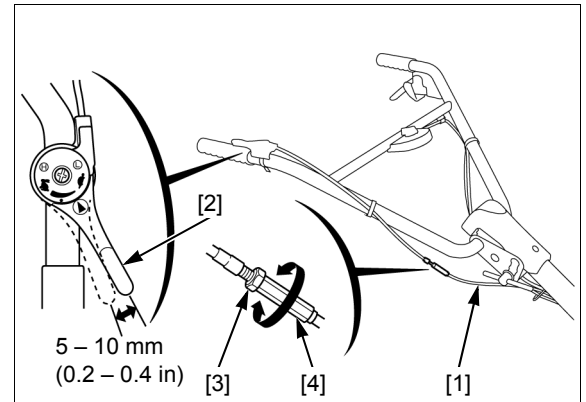

## VALVE CLEARANCE CHECK/ ADJUSTMENT

### NOTICE

- Valve clearance inspection and adjustment must be performed with the engine cold.

Remove the following:

- Engine (page 10-2)
- Recoil starter (page 8-2)

Remove the head cover bolts [1], cylinder head cover [2] and cylinder head cover gasket [3].

NOTE:

- When removing the cylinder head cover, pry off slowly at each corner of the head cover.

### NOTICE

- Using too much force can deform the cylinder head cover. The cylinder head cover must be replaced if it is deformed.

Align the "△" mark [1] on the starter pulley [2] with the top hole [3] on the fan cover [4].

This will set the piston at top dead center of the compression stroke (both valves are fully closed).

If the exhaust valve is opened, turn the starter pulley one additional turn and align the "△" mark on the starter pulley with the top hole on the fan cover.

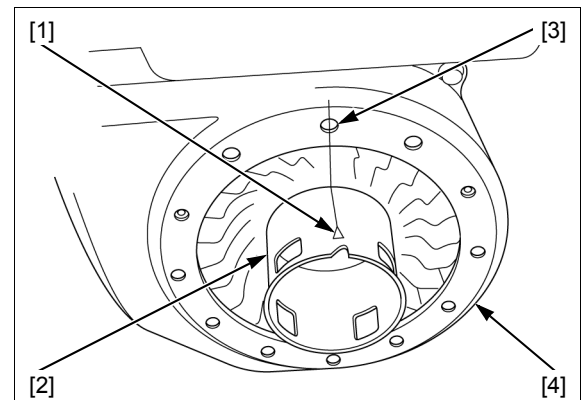
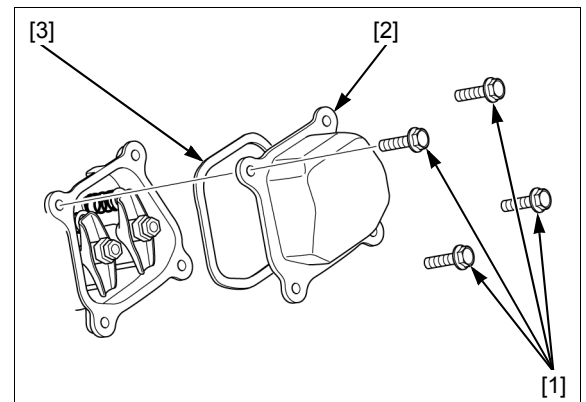

## MAINTENANCE

Insert a thickness gauge [1] between the rocker arm [2] and valve stem [3] to check the valve clearance.

### VALVE CLEARANCE:

**IN:**  $0.15 \pm 0.02$  mm ( $0.006 \pm 0.001$  in)

**EX:**  $0.20 \pm 0.02$  mm ( $0.008 \pm 0.001$  in)

If adjustment is necessary, proceed as follows.

Hold the rocker arm pivot [4] and loosen the rocker arm pivot lock nut (6 mm) [5].

Adjust by turning the rocker arm pivot until there is a slight drag on the thickness gauge.

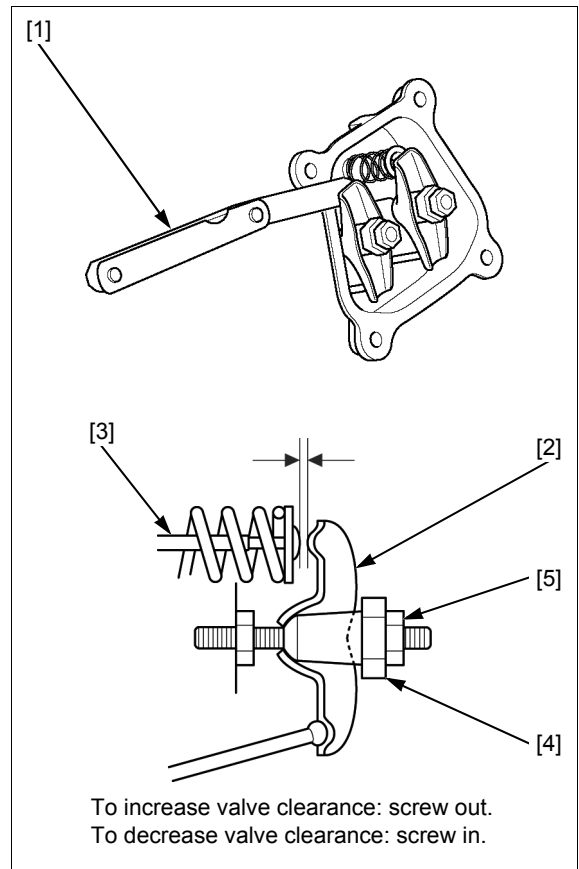

Hold the rocker arm pivot [1] and retighten the rocker arm pivot lock nut (6 mm) [2] to the specified torque.

**TORQUE: 10 N·m (1.0 kgf·m, 7 lbf·ft)**

Recheck the valve clearance, and if necessary, readjust the clearance.

Installation is in the reverse order of removal.

Check the V-belt tension (page 3-7).

*Do not reuse the cylinder head cover gasket.*

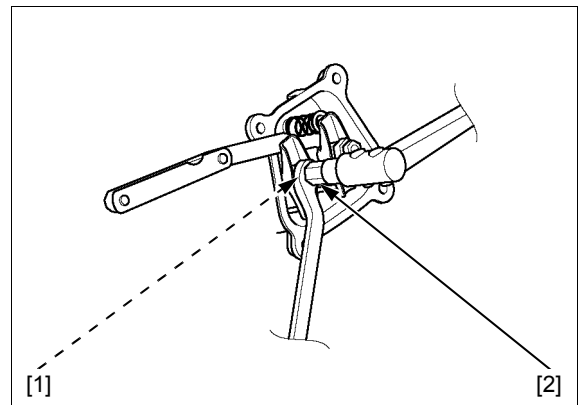

## COMBUSTION CHAMBER CLEANING

Remove the cylinder head (page 12-3).

Clean any carbon deposits from the combustion chamber [1].

Install the cylinder head (page 12-3).

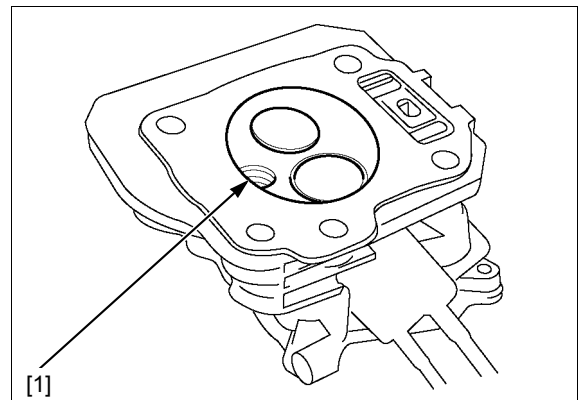

## FUEL TANK AND FILTER CLEANING

### ⚠ WARNING

Gasoline is highly flammable and explosive. You can be burned or seriously injured when handling fuel.

- Keep heat, sparks and flame away.
- Handle fuel only outdoors.
- Wipe up spills immediately.

Remove the fuel tank (page 5-3).

Remove the two tube clips (8 mm) [1] and disconnect the fuel tube [2].

Remove the fuel filter joint [3].

Remove the O-ring [4] from the fuel filter joint.

Wash the fuel filter joint in nonflammable or high flash point solvent.

Inspect the fuel filter screen to be sure it is undamaged.

Clean the fuel tank [5] with nonflammable or high flash point solvent and allow to dry thoroughly.

Check to be sure new O-ring is in place, and install the fuel filter joint.

Tighten the fuel filter joint to the specified torque.

**TORQUE: 2 N·m (0.2 kgf·m, 1.5 lbf·ft)**

Install the fuel tank (page 5-3).

Make sure there are no fuel leaks.

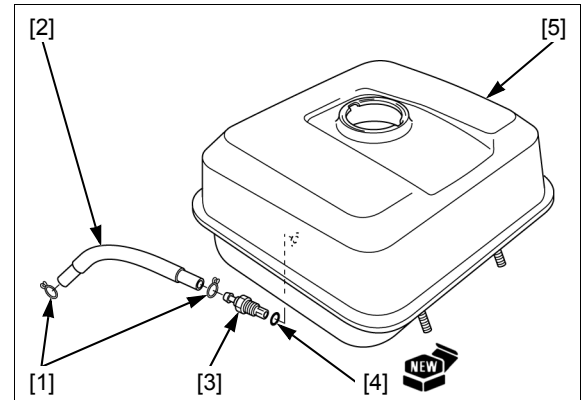

## FUEL TUBE INSPECTION

### ⚠ WARNING

Gasoline is highly flammable and explosive. You can be burned or seriously injured when handling fuel.

- Keep heat, sparks, and flame away.
- Wipe up spills immediately.
- Handle fuel only outdoors.

Remove the fan cover (page 7-3).

Check the fuel tube [1] for damage, fuel leakage, corrosion, and other abnormalities.

Check that the fuel tube is not interfering with the neighboring parts.

Replace the fuel tube if there is damage, fuel leakage or, corrosion (page 5-3).

Install the fan cover (page 7-3).

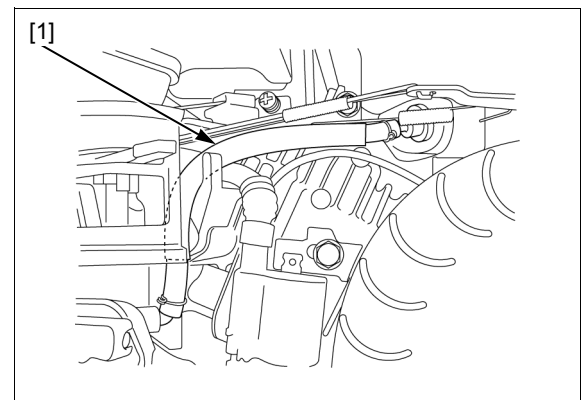

---

**MEMO**

---

**BEFORE TROUBLESHOOTING**.....4-2

**GENERAL SYMPTOMS AND POSSIBLE CAUSES** .....4-2

**ENGINE TROUBLESHOOTING** .....4-3

**FRAME TROUBLESHOOTING** .....4-3

### BEFORE TROUBLESHOOTING

- Check that the engine stop switch wire connector and ignition coil wire connector are connected securely.
- Check for sufficient fresh fuel in the fuel tank.

### GENERAL SYMPTOMS AND POSSIBLE CAUSES

#### HARD STARTING

- Fuel tube or filter restricted
  - Clean (page 3-15)
- Carburetor out of adjustment
  - Adjust (page 3-11)
  - Disassemble and inspect (page 5-6)
- Ignition coil air gap misadjusted
  - Adjust (page 7-5)
- Ignition coil faulty
  - Inspect (page 7-6)
- Spark plug faulty
  - Inspect (page 3-12)
- Governor misadjusted
  - Adjust (page 6-3)
- Valve clearance incorrect
  - Adjust (page 3-13)

#### ENGINE LACKS POWER

- Spark plug faulty
  - Inspect (page 3-12)
- Governor misadjusted
  - Adjust (page 6-3)
- Valve clearance incorrect
  - Adjust (page 3-13)
- Valve seat worn or damaged
  - Inspect and correct (page 12-10)
- Cylinder, piston or piston rings worn
  - Disassemble and inspect (page 13-3)

#### ENGINE WILL NOT REV SUFFICIENTLY

- Carburetor out of adjustment
  - Disassemble and inspect (page 5-6)

#### POOR PERFORMANCE AT LOW SPEED

- Carburetor out of adjustment
  - Disassemble and inspect (page 5-6)
- Governor misadjusted
  - Adjust (page 6-3)
- Valve clearance incorrect
  - Adjust (page 3-13)

#### POOR PERFORMANCE AT HIGH SPEED

- Spark plug faulty
  - Inspect (page 3-12)
- Governor misadjusted
  - Adjust (page 6-3)

## ENGINE TROUBLESHOOTING

### HARD STARTING

#### 1. Spark Plug Inspection

Inspect the spark plug (page 3-12).

***Is the spark plug in good condition?***

**YES** – GO TO STEP 2.

- NO** –
- Faulty spark plug
  - Incorrect spark plug gap
  - Faulty carburetor float valve and/or float (If the spark plug is wet severely)
    - Inspection (page 5-6)
  - Clogged fuel filter
    - Inspection (page 3-15)
  - Clogged fuel tube
    - Inspection (page 3-15)
  - Clogged carburetor port, nozzle
    - Inspection (page 5-6)

#### 2. Ignition System Inspection

Check the ignition system (page 7-2).

***Is the ignition system normal?***

**YES** – GO TO STEP 3.

**NO** – Faulty ignition system

#### 3. Cylinder Compression Inspection

Test the cylinder compression (page 12-5).

***Is the compression normal?***

- NO** –
- Carbon deposits in the combustion chamber
    - Cleaning (page 3-14)
  - Valve clearance incorrect
    - Adjustment (page 3-13)
  - Defective cylinder head gasket, valves, valve seats
    - Disassembly and inspection (page 12-3)
  - Loosen cylinder head bolts
    - Retightening (page 12-3)
  - Worn cylinder, piston, piston rings
    - Disassembly and inspection (page 13-3)
  - Worn valves
    - Inspection (page 12-5)

## FRAME TROUBLESHOOTING

### CLUTCH CAN NOT BE DISENGAGED

- Clutch cable misadjusted
  - Adjust (page 3-6)
- Tension arm return spring defective
  - Replace (page 15-7)
- V-belt misadjusted
  - Adjust (page 3-7)
- Tension arm binding on tension arm shaft
  - Clean and lubricate (page 15-7)

### CLUTCH CAN NOT BE ENGAGED

- Clutch cable misadjusted
  - Adjust (page 3-6)
- V-belt misadjusted
  - Adjust (page 3-7)
- Tension arm binding on tension arm shaft
  - Clean and lubricate (page 15-7)

---

**MEMO**

---

TOOL .....	5-2	CARBURETOR REMOVAL/ INSTALLATION .....	5-5
FUEL TANK REMOVAL/INSTALLATION .....	5-3	CARBURETOR DISASSEMBLY/ ASSEMBLY .....	5-6
AIR CLEANER REMOVAL/ INSTALLATION .....	5-4		

## FUEL SYSTEM

---

### TOOL

Float level gauge  
07401-0010000

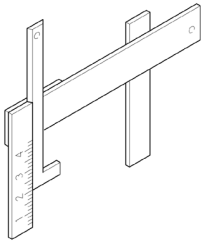

# FUEL TANK REMOVAL/INSTALLATION

**⚠ WARNING**

Gasoline is highly flammable and explosive. You can be burned or seriously injured when handling fuel.

- Keep heat, sparks and flame away.
- Handle fuel only outdoors.
- Wipe up spills immediately.

Remove the air cleaner (page 5-4).

Turn the fuel valve lever to the "OFF" position.

Disconnect the fuel tube from the carburetor (page 5-5) and drain the fuel into a suitable container.

**NOTE:**

- After installation, route the fuel tube to the carburetor insulator properly (page 2-8).

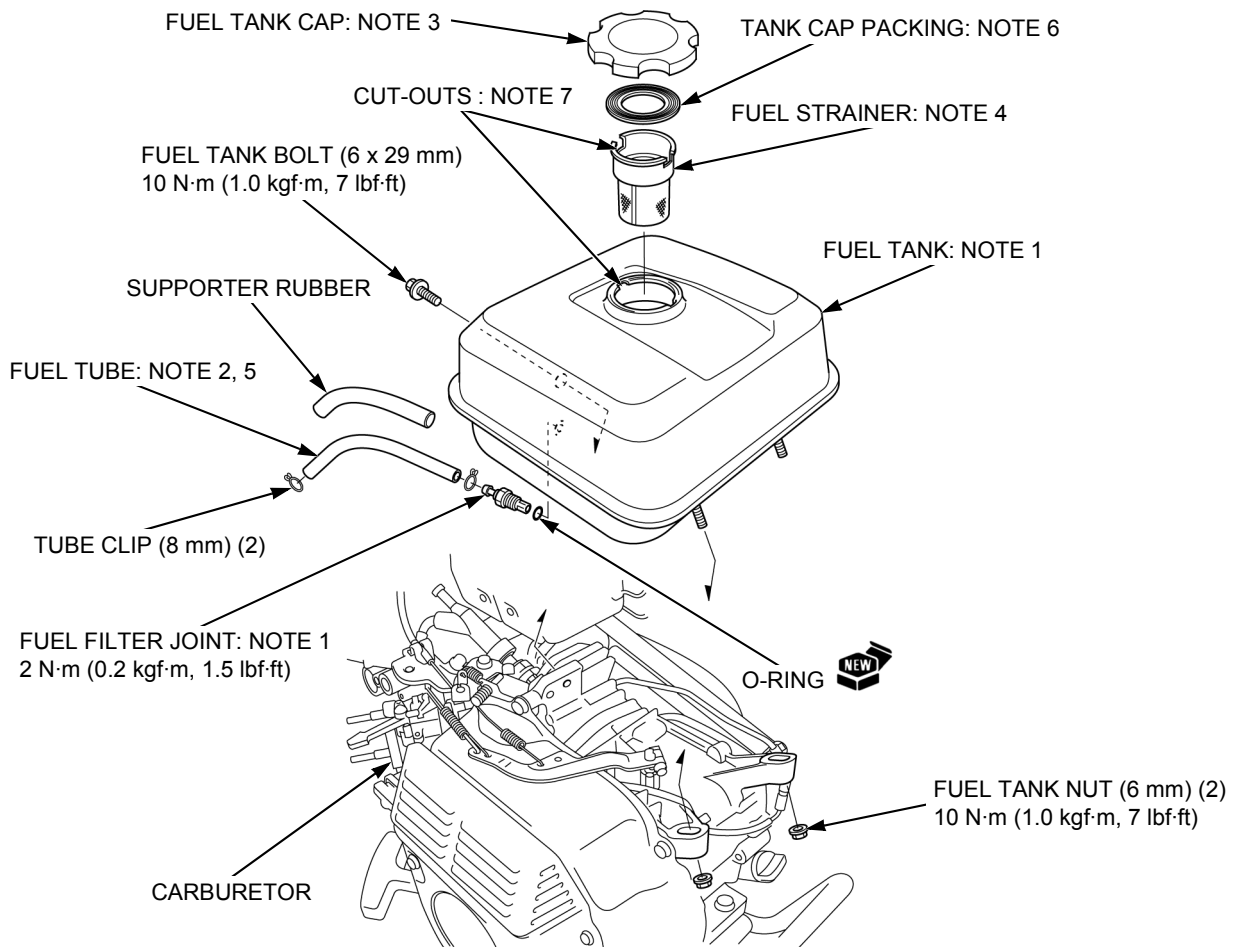

NOTE 1	FUEL TANK AND FILTER CLEANING	page 3-15
NOTE 2	FUEL TUBE INSPECTION	page 3-15
NOTE 3	When reassembly, make sure that air vent hole is clean and unclogged. Blow with compressed air if necessary.	—
NOTE 4	When reassembly, make sure that the strainer is clean and undamaged.	—
NOTE 5	When reassembly, check for crack or deterioration before installation and replace if necessary.	—
NOTE 6	Check the tank cap packing for wear or damage. Replace it if necessary.	—
NOTE 7	When reassembly, align the cut-outs.	—

# FUEL SYSTEM

## AIR CLEANER REMOVAL/ INSTALLATION

**NOTE:**

- When installation, route the breather tube properly (page 2-8).

HOSE BAND: NOTE 6, 7, 8

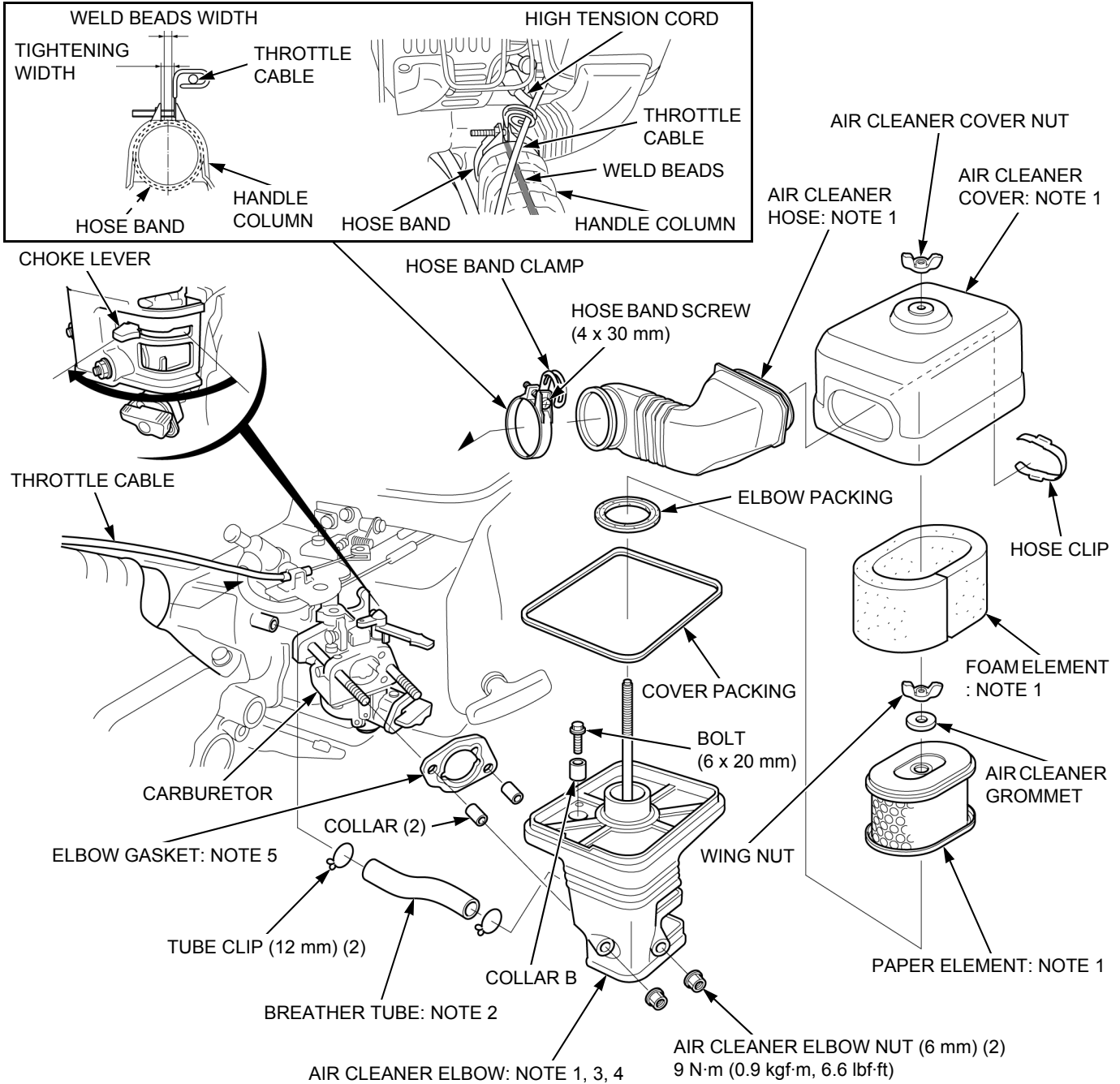

NOTE 1	AIR CLEANER CHECK/CLEANING	page 3-5
NOTE 2	Before installation, check for cracks or deterioration.	—
NOTE 3	Remove and install with the choke lever in the ON position as shown.	—
NOTE 4	Before installation, clean the inside of the elbow with compressed air.	—
NOTE 5	Note the installation direction.	—
NOTE 6	Install the hose band with extended line of handle column weld beads.	—
NOTE 7	After installation, clamp the throttle cable with hose band clamp securely.	—
NOTE 8	Make sure the throttle cable do not interfere with the high tension cord.	—

# CARBURETOR REMOVAL/ INSTALLATION

## ⚠ WARNING

Gasoline is highly flammable and explosive. You can be burned or seriously injured when handling fuel.

- Keep heat, sparks and flame away.
- Handle fuel only outdoors.
- Wipe up spills immediately.

Turn the fuel valve to the "OFF" position, and then disconnect the fuel tube from the carburetor.

Remove the air cleaner (page 5-4).

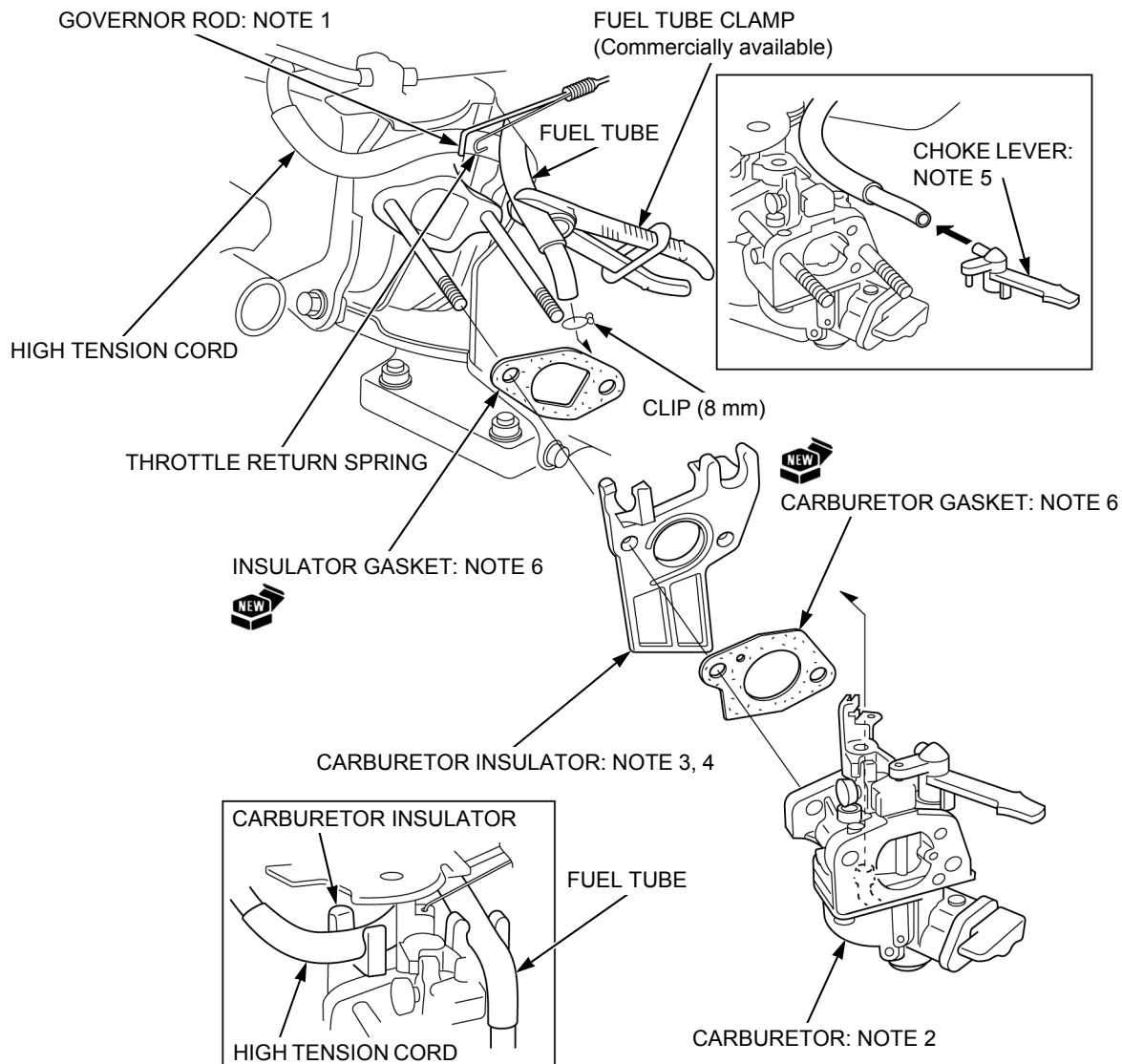

NOTE 1	GOVERNOR ROD REMOVAL/INSTALLATION	page 5-6
NOTE 2	CARBURETOR DISASSEMBLY/ASSEMBLY	page 5-6
NOTE 3	Before installation, blow out of the passages with compressed air.	—
NOTE 4	After installation, connect the high tension cord and fuel tube securely.	—
NOTE 5	The short peg on the choke lever can be used to plug the end of the fuel tube.	—
NOTE 6	Note the installation direction.	—

## FUEL SYSTEM

### GOVERNOR ROD REMOVAL/ INSTALLATION

Pull the carburetor toward a point where the groove [1] in the throttle arm [2] lines up with the governor rod [3], and lift the rod out of its hole and unhook the throttle return spring [4].

Installation is in the reverse order of removal.

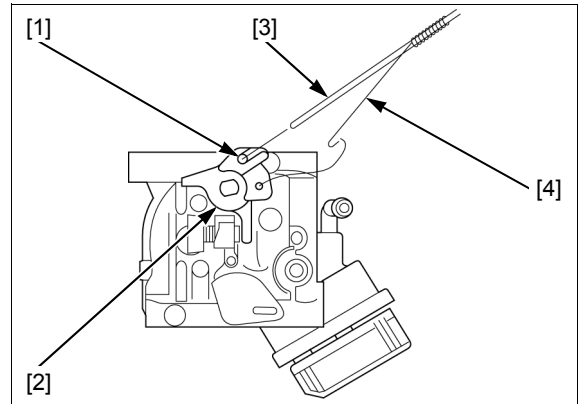

### CARBURETOR DISASSEMBLY/ ASSEMBLY

#### **⚠ WARNING**

Gasoline is highly flammable and explosive. You can be burned or seriously injured when handling fuel.

- Keep heat, sparks and flame away.
- Handle fuel only outdoors.
- Wipe up spills immediately.

#### **⚠ CAUTION**

- To prevent serious eye injury, always wear safety goggles or other eye protection when using compressed air.
- Turn the fuel valve lever to the "DRAIN" position and drain the fuel before disassembling. Fuel vapor or spilled fuel may ignite.

#### NOTE:

- The pilot screw adjustment and removal can not be done.
- If clean the valve seal, replace it with a new one for molybdenum coating coming off.

Remove the carburetor (page 5-5).

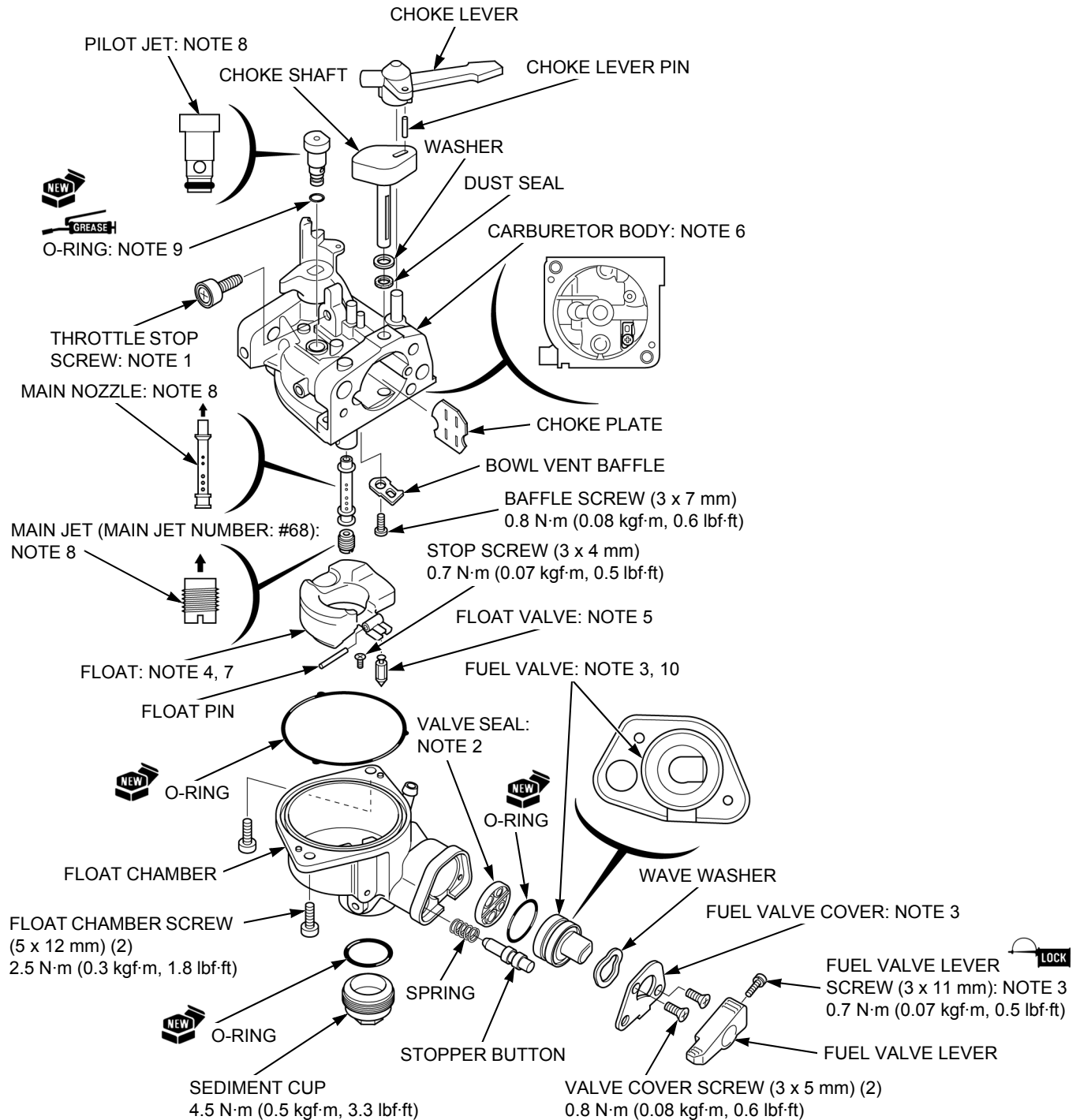

NOTE 1	ENGINE IDLE SPEED	page 3-11
NOTE 2	VALVE SEAL INSTALLATION	page 5-8
NOTE 3	LUBRICATION	page 5-8
NOTE 4	FLOAT LEVEL HEIGHT INSPECTION	page 5-9
NOTE 5	FLOAT VALVE INSPECTION	page 5-9
NOTE 6	CARBURETOR BODY CLEANING	page 5-10
NOTE 7	After installation, check for smooth movement.	—
NOTE 8	Before installing, clean thoroughly with low pressure compressed air.	—
NOTE 9	When installation, lightly lubricate the O-ring to ensure easy installation into the carburetor body.	—
NOTE 10	Install it in the direction as shown.	—

## FUEL SYSTEM

### VALVE SEAL INSTALLATION

Install the valve seal [1] into the float chamber [2] with its rib [3] side facing out, while aligning the hole of the valve seal with boss of the float chamber.

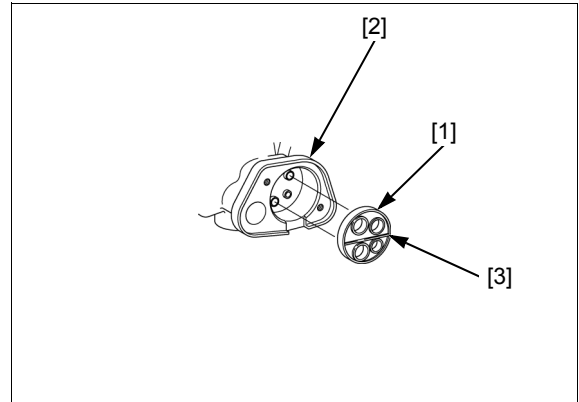

### LUBRICATION

#### FUEL VALVE COVER/FUEL VALVE

When reassembly, apply silicone grease to the fuel valve [1] groove and fuel valve cover [2] sliding surface as shown.

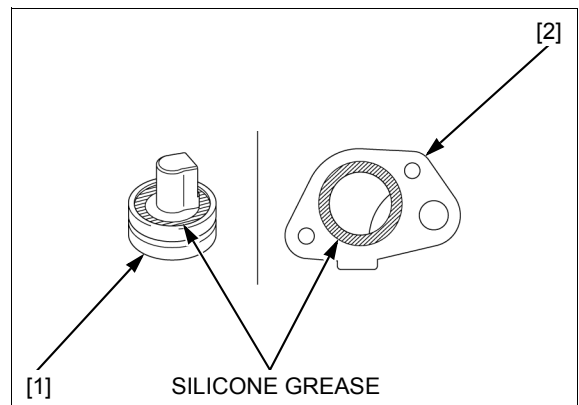

#### FUEL VALVE LEVER SCREW (3 x 11 mm)

When reassembly, apply LOCTITE® 271 or equivalent to the threads as shown.

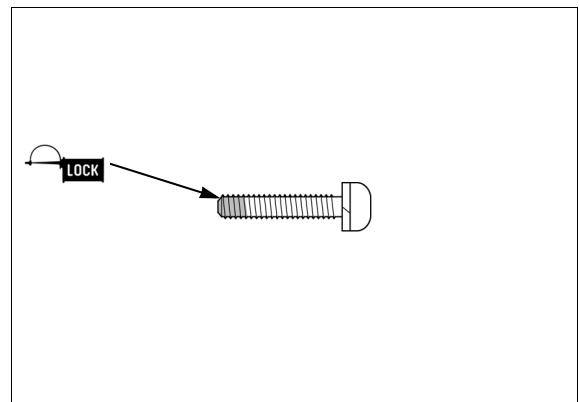

### FLOAT LEVEL HEIGHT INSPECTION

Place the float chamber [1] in the position as shown, and measure the distance between the float top [2] and float chamber when the float just contacts the float valve without compressing the valve.

**TOOL:**

**Float level gauge [3]                      07401-0010000**

**Standard float level height: 3.4 mm (0.13 in)**

If the height is outside the specification, replace the float and the float valve and recheck the float level height.

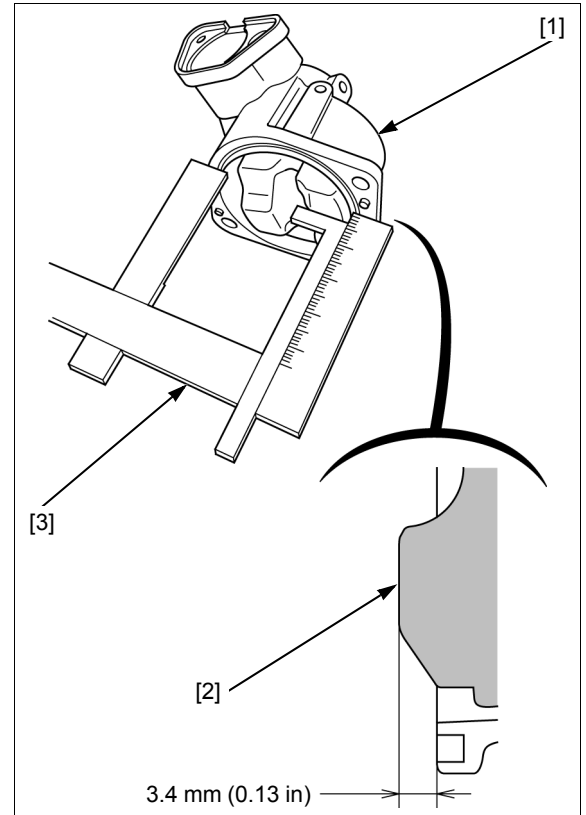

### FLOAT VALVE INSPECTION

Check the tip of the float valve [1] where it contacts the valve seat [2] for stepped wear or contamination. Replace the valve if the tip is worn or contaminated.

Check the operation of the float valve.

Inspect the float valve seat for scores, scratches, clogging and damage.

If the seat is damaged, replace the float chamber.

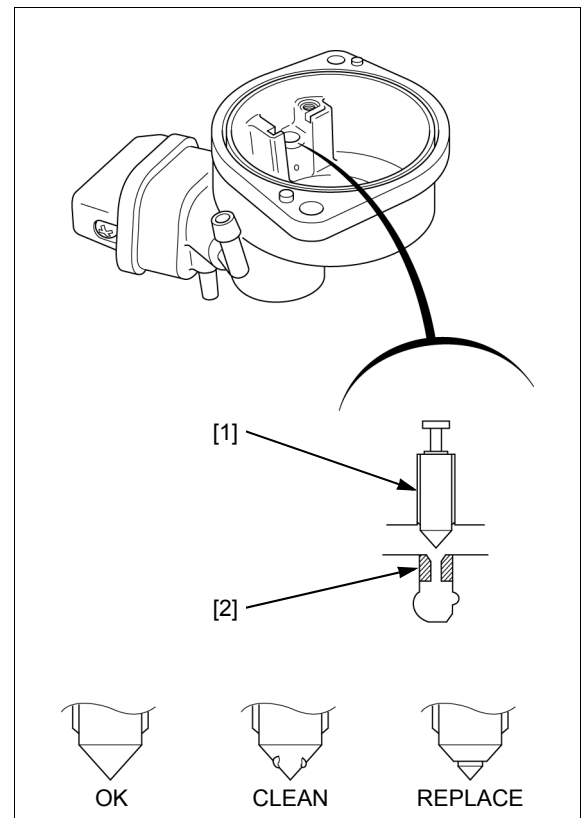

**CARBURETOR BODY CLEANING**

**⚠ CAUTION**

- To prevent serious eye injury, always wear safety goggles or other eye protection when using compressed air.
- Some commercially-available chemical cleaners are very caustic. These cleaners may damage plastic parts such as O-rings, float and float valve seats. Check the container for instructions.  
If you are in doubt, do not use these products to clean Honda carburetors.
- High air pressure may damage the carburetor. Use low pressure settings when cleaning passages and ports.

Clean the carburetor body [1] and float chamber [2] with solvent.

Use low air pressure and clean the following parts and passages:

**ENGINE SIDE:**

- External vent port [3]
- Transition ports [4]
- Pilot outlet [5]

**AIR CLEANER SIDE:**

- Pilot jet hole [6]
- Pilot air jet [7]
- Main air jet [8]
- Main nozzle holder [9]

**FLOAT CHAMBER:**

- Float valve seat [10]
- Stopper button installation hole [11]
- Each valve hole [12]
- Float chamber holes [13]

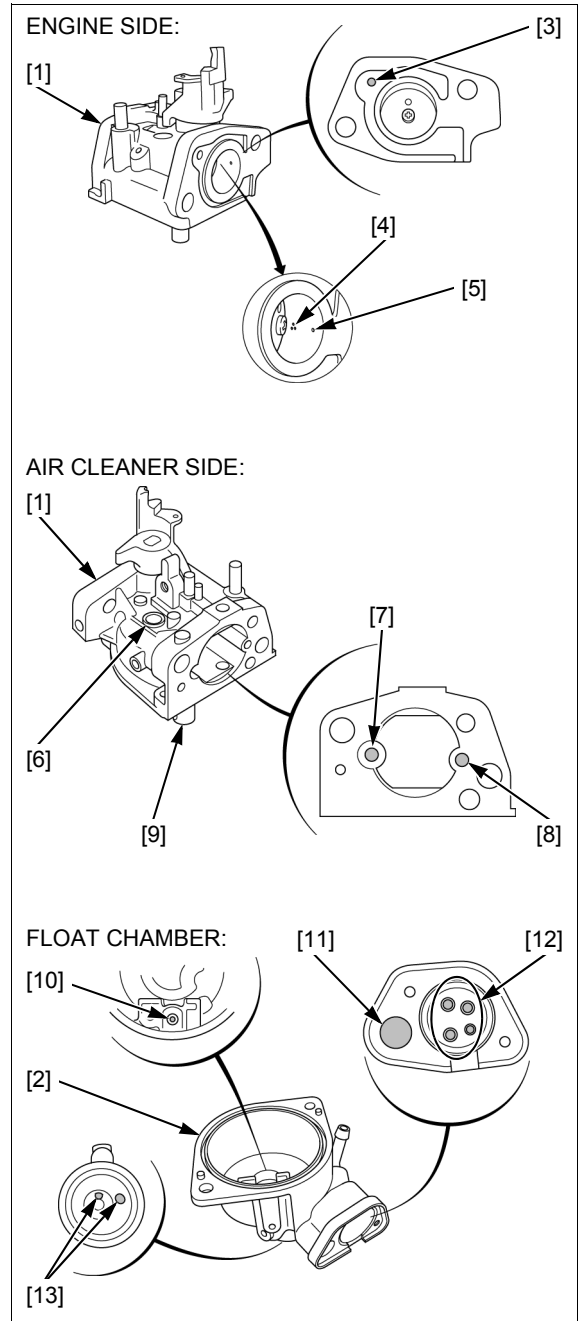

# 6. GOVERNOR SYSTEM

---

CONTROL BASE/GOVERNOR ARM  
REMOVAL/INSTALLATION .....6-2

GOVERNOR ADJUSTMENT ..... 6-3

GOVERNOR REMOVAL/INSTALLATION.... 6-4

## GOVERNOR SYSTEM

# CONTROL BASE/GOVERNOR ARM REMOVAL/INSTALLATION

Remove the fuel tank (page 5-3).  
Disconnect the throttle cable (page 10-2).

After installation, perform the "GOVERNOR  
ADJUSTMENT" (page 6-3).

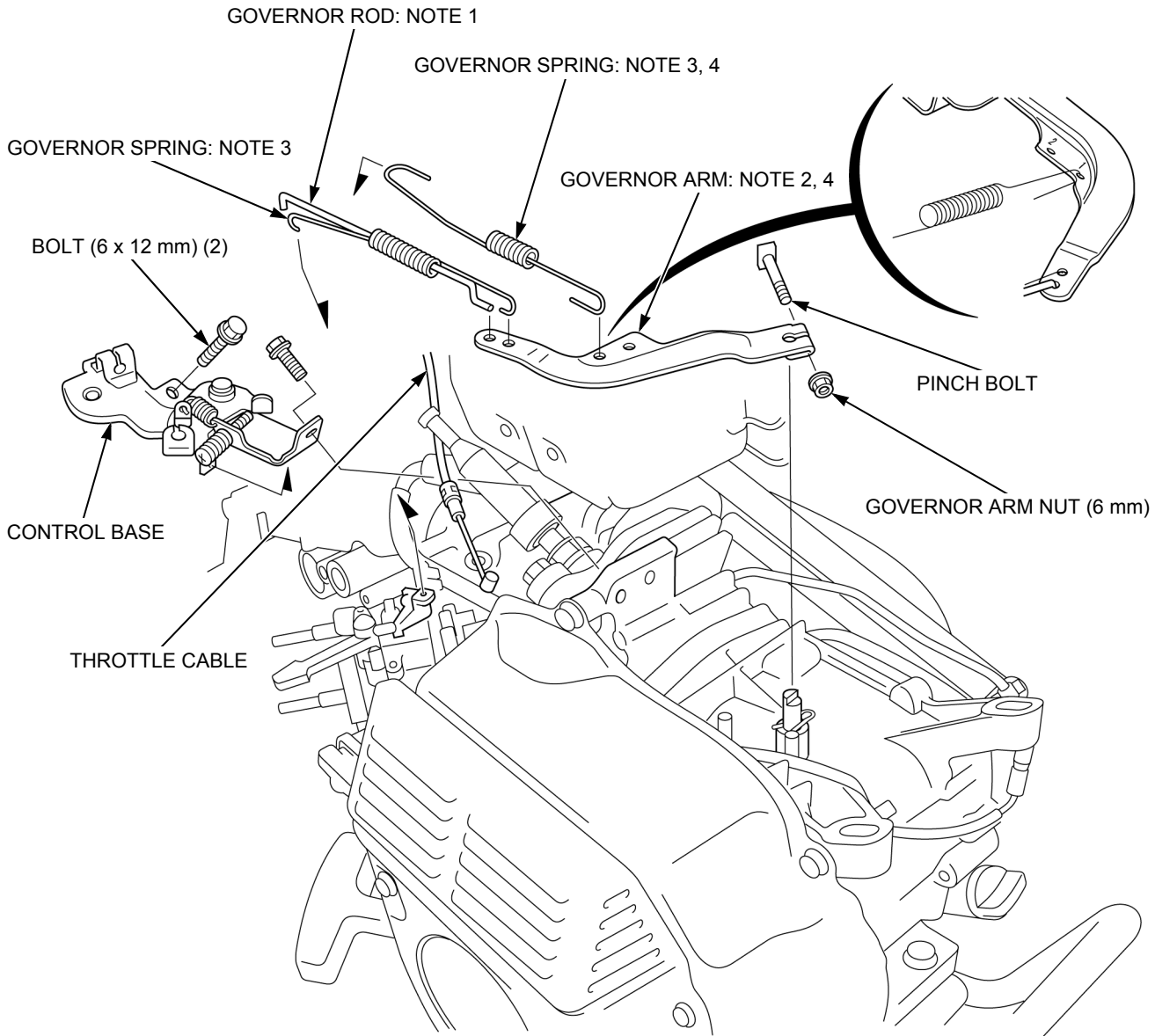

NOTE 1	GOVERNOR ROD REMOVAL/INSTALLATION	page 5-6
NOTE 2	GOVERNOR ADJUSTMENT	page 6-3
NOTE 3	When reassembly, install the spring with the long end side toward the control base.	-
NOTE 4	When installation, hook the throttle return spring on the hole marked "1".	-

## GOVERNOR ADJUSTMENT

Remove the fuel tank (page 5-3).

Loosen the governor arm nut (6 mm) [1] and then move the governor arm [2] so that the throttle is completely open.

Rotate the governor arm shaft [3] as far as it will go in the direction that it was just turned by the governor arm.

Tighten the governor arm nut to the specified torque and then make sure that the clearance is normal as shown.

**TORQUE: 3 N·m (0.3 kgf·m, 2.2 lbf·ft)**

Install the fuel tank (page 5-3).

NOTE:

- Use a tachometer with graduations of  $50 \text{ min}^{-1}$  (rpm) or smaller that will accurately indicate a  $50 \text{ min}^{-1}$  (rpm) change.

Warm up the engine.

Stop the engine and connect a tachometer according to manufacturer's operating instruction.

Start the engine and bring the engine to its standard speed with the throttle lever.

Adjust the throttle control screw [4] so that the throttle cannot be moved past this point.

**MAXIMUM ENGINE SPEED (AT NO LOAD):**

$$3,800 \begin{matrix} 0 \\ -200 \end{matrix} \text{ min}^{-1} \text{ (rpm)}$$

After adjustment, adjust the engine idle speed (page 3-11) and throttle cable (page 3-13).

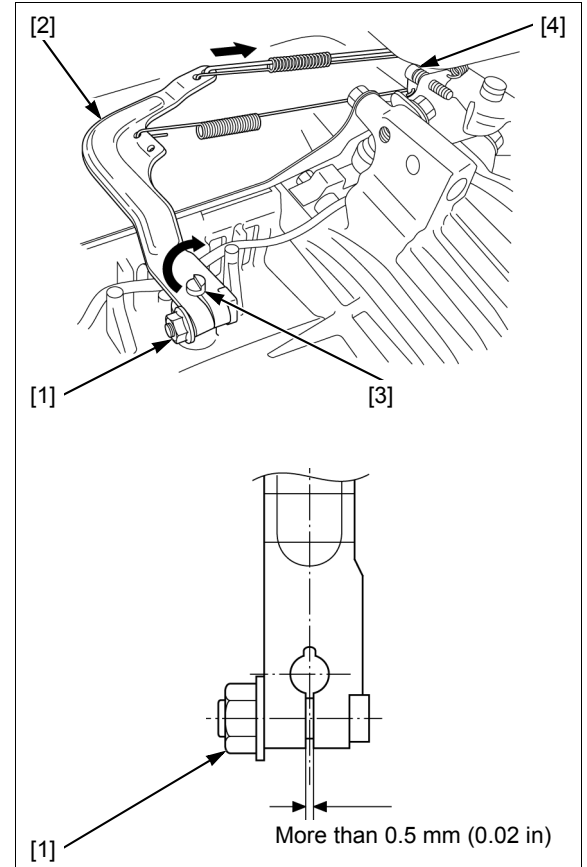

## GOVERNOR SYSTEM

# GOVERNOR REMOVAL/INSTALLATION

Remove the crankshaft (page 13-3).

**NOTE:**

- Be sure to install the governor before installing the crankshaft.

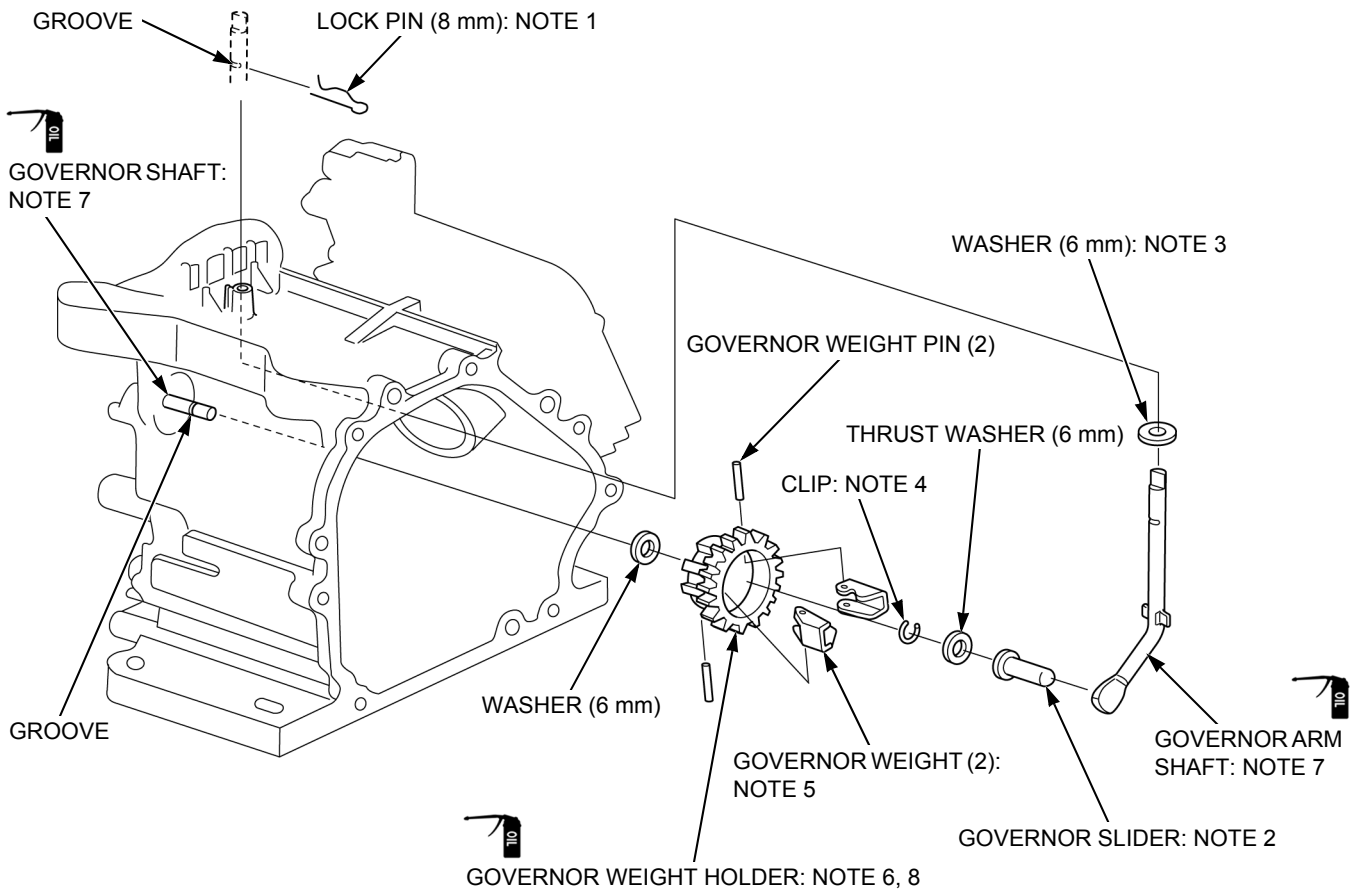

NOTE 1	<ul style="list-style-type: none"> <li>• When reassembly, install the lock pin immediately after installing the governor arm shaft, and move the shaft over against the governor slider.</li> <li>• The lock pin (8 mm) must be installed with the straight side of the lock pin against the groove of the governor arm shaft.</li> </ul>	—
NOTE 2	When reassembly, spread the governor weight to install the governor slider; then check to be sure slider moves smoothly.	—
NOTE 3	When reassembly, install inside the cylinder block.	—
NOTE 4	When reassembly, install firmly into the governor shaft groove.	—
NOTE 5	When reassembly, check that the weights move freely.	—
NOTE 6	Before installation, check for wear and damage of the gear.	—
NOTE 7	When reassembly, apply engine oil to the journal.	—
NOTE 8	When reassembly, apply engine oil to the gear and sliding surface.	—

# 7. IGNITION SYSTEM

---

BEFORE TROUBLESHOOTING.....7-2

IGNITION SYSTEM  
TROUBLESHOOTING.....7-2

FLYWHEEL/IGNITION COIL REMOVAL/  
INSTALLATION.....7-3

SPARK TEST ..... 7-6

ENGINE STOP SWITCH REMOVAL/  
INSTALLATION ..... 7-7

# BEFORE TROUBLESHOOTING

- Check that the engine stop switch wire connector and ignition coil wire connector are connected securely.
- Check that the engine stop switch is "ON" position.

## IGNITION SYSTEM TROUBLESHOOTING

### HARD STARTING

#### 1. Spark Plug Inspection

Inspect the spark plug (page 3-12).

***Is the spark plug normal?***

**YES** – GO TO STEP 2.

**NO** – • Faulty spark plug  
• Incorrect spark plug gap

#### 2. Spark Test

Clean the spark plug and adjust the spark plug gap (page 3-12)

Perform the spark test (page 7-6).

***Is there weak or no spark?***

**YES** – GO TO STEP 3.

**NO** – • Faulty spark plug  
• Incorrect spark plug gap

#### 3. Spark Test

Perform the spark test again with a new spark plug (page 7-6).

***Is there weak or no spark?***

**YES** – GO TO STEP 4.

**NO** – Faulty spark plug

#### 4. Spark Plug Cap Inspection

Inspect the spark plug cap (page 7-6).

***Is the spark plug cap normal?***

**YES** – GO TO STEP 5.

**NO** – Faulty spark plug cap

#### 5. Engine stop switch Inspection

Inspect the engine stop switch (page 7-7).

***Is the engine stop switch normal?***

**YES** – GO TO STEP 6.

**NO** – Faulty engine stop switch

#### 6. Ignition Coil Air Gap Inspection

Inspect the ignition coil air gap (page 7-5).

***Is the ignition coil air gap normal?***

**YES** – GO TO STEP 7.

**NO** – Ignition coil air gap misadjusted

#### 7. Ignition Coil Inspection

Inspect the ignition coil (page 7-6).

***Is the ignition coil normal?***

**NO** – Ignition coil defective

# FLYWHEEL/IGNITION COIL REMOVAL/INSTALLATION

## NOTICE

- When disassembling and reassembling, take care not to damage the fan blade.

Remove the following:

- Recoil starter (page 8-2)
- Carburetor (page 5-5)
- Fuel tank (page 5-3)

NOTE:

- After installation, perform the "IGNITION COIL AIR GAP CHECK/ADJUSTMENT" (page 7-5)

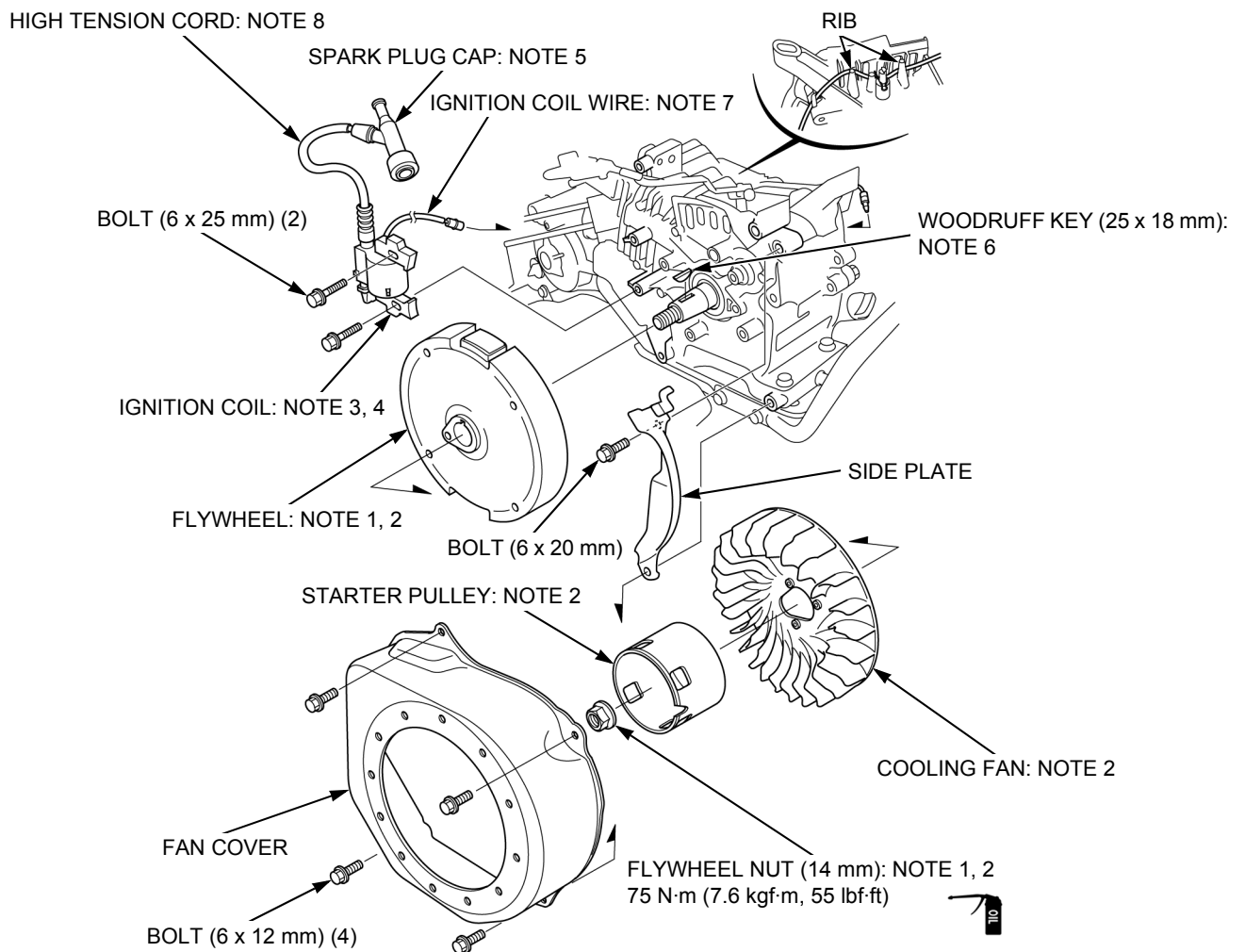

NOTE 1	FLYWHEEL REMOVAL	page 7-4
NOTE 2	FLYWHEEL INSTALLATION	page 7-4
NOTE 3	IGNITION COIL AIR GAP CHECK/ADJUSTMENT	page 7-5
NOTE 4	IGNITION COIL INSPECTION	page 7-6
NOTE 5	SPARK PLUG CAP INSPECTION	page 7-6
NOTE 6	After installing the flywheel, check to be sure that the woodruff key is still in its slot on the crankshaft.	-
NOTE 7	When reassembly, insert securely into the two ribs on the cylinder block as shown.	-
NOTE 8	Check for cracked or damage insulation and replace the ignition coil if necessary.	-

# IGNITION SYSTEM

## FLYWHEEL REMOVAL

Hold the flywheel [1] with a commercially available strap wrench [2] and remove the nut (14 mm) [3].

### NOTICE

- Take care not to damage the cooling fan with the strap wrench.

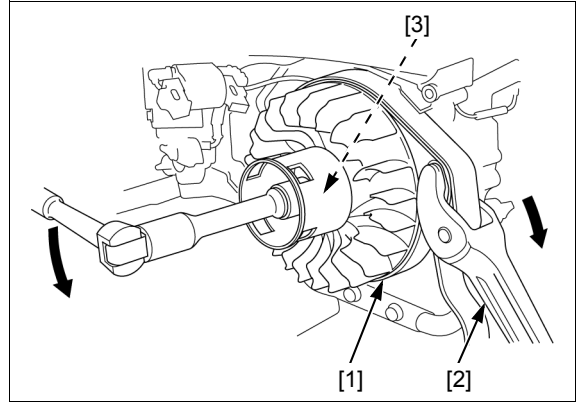

Remove the flywheel [1] with a commercially available flywheel puller [2].

### NOTICE

- Do not hit the flywheel with a hammer.
- Avoid the magnet section when attaching the flywheel puller.

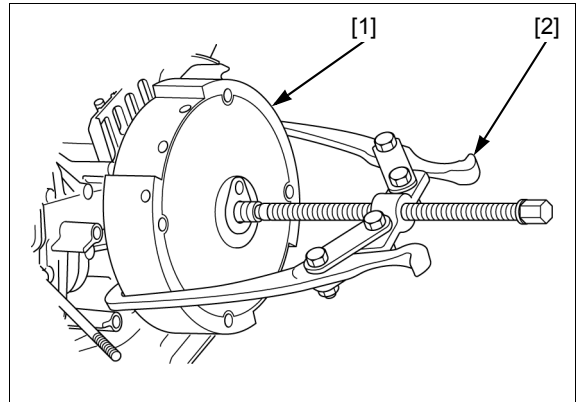

## FLYWHEEL INSTALLATION

Clean the tapered parts [1] of dirt, oil, grease, and other foreign material before installation.

Be sure there are no metal parts or other foreign material on the magnet part [2] of the flywheel.

Set the woodruff key (25 x 18 mm) [3] in the key groove [4] of the crankshaft securely.

Install the flywheel [5] by aligning the key slot [6] with woodruff key on the crankshaft.

### NOTICE

- The flywheel may push the woodruff key (25 x 18 mm) out of its slot; check after installation.

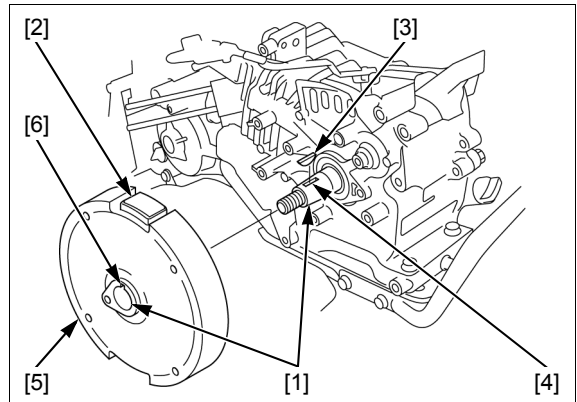

Attach the cooling fan [1] to the flywheel [2] by aligning the four projections of the cooling fan with the holes of the flywheel.

Attach the starter pulley [3] by aligning the hole of the pulley with the projection at the center of the cooling fan.

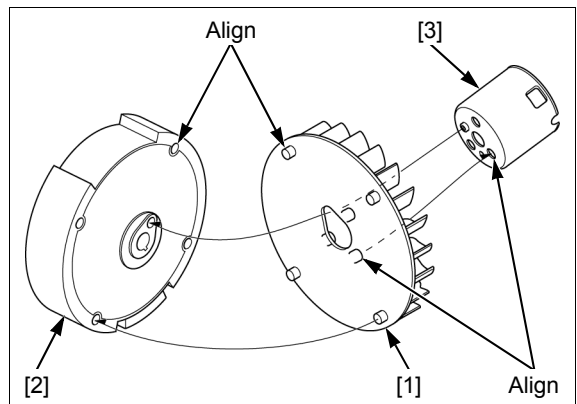

Apply engine oil to the threads and seating surface of the nut (14 mm) [1], and loosely tighten the nut.

Hold the flywheel [2] with a commercially available strap wrench [3], and tighten the nut (14 mm) to the specified torque.

**TORQUE: 75 N·m (7.6 kgf·m, 55 lbf·ft)**

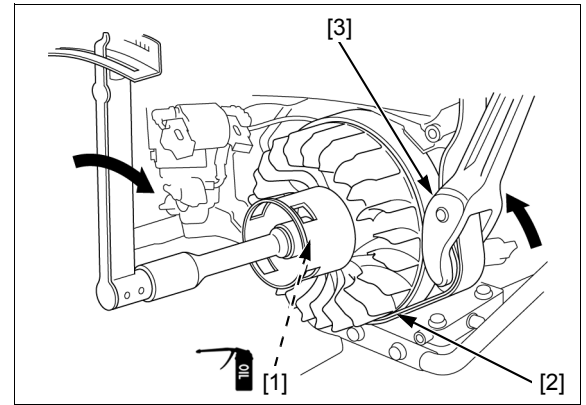

## IGNITION COIL AIR GAP CHECK/ADJUSTMENT

### NOTICE

- Avoid the magnet part of the flywheel when adjusting.
- Adjust the ignition coil air gap equally on both side.

Measure the ignition coil air gap clearance.

### IGNITION COIL AIR GAP:

**0.20 – 0.60 mm (0.008 – 0.024 in)**

If measured clearance is out of specification, adjust the clearance.

Loosen the two ignition coil bolts (6 x 25 mm) [1].

Insert the thickness gauge of proper thickness between the ignition coil [2] and flywheel [3].

Push the ignition coil firmly against the flywheel and tighten the ignition coil bolts securely.

Remove the thickness gauge.

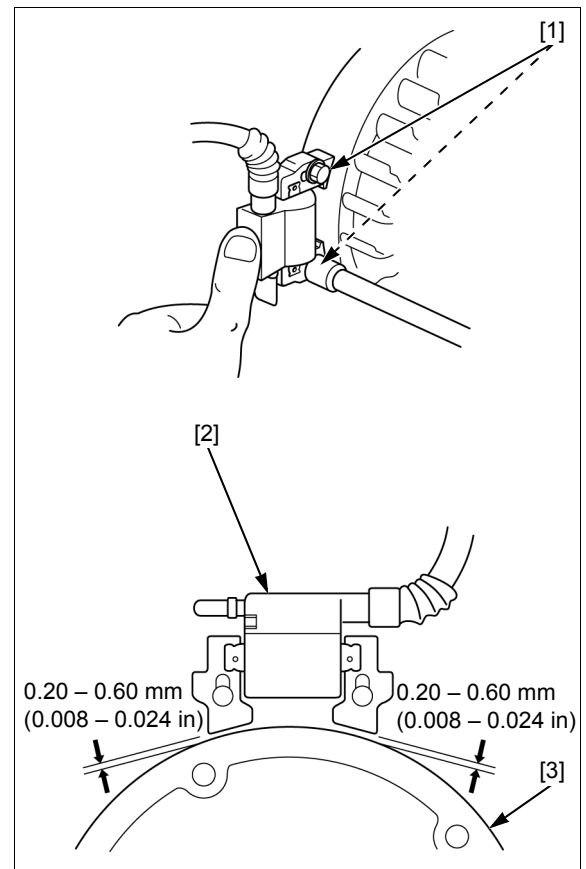

## IGNITION SYSTEM

### IGNITION COIL INSPECTION

#### PRIMARY SIDE

Measure the resistance of primary coil by attaching one ohmmeter probe to the ignition coil wire terminal and the other at the iron core.

**RESISTANCE: 0.81 – 0.99  $\Omega$**

If measured resistance is out of specification, replace the ignition coil.

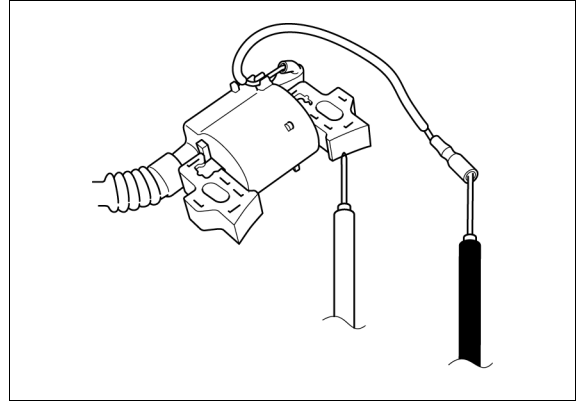

#### SECONDARY SIDE

Measure the resistance of secondary coil by attaching one ohmmeter probe to the terminal in the spark plug cap and the other at the iron core.

**RESISTANCE: 5.85 – 7.15 k $\Omega$**

If measured resistance is out of specification, replace the ignition coil.

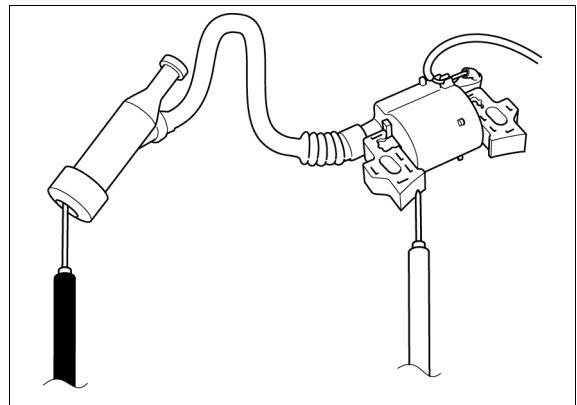

### SPARK PLUG CAP INSPECTION

Measure the resistance of spark plug cap [1] by attaching one ohmmeter probe to the terminal in the spark plug cap and the other at the terminal connected high tension wire.

**RESISTANCE: 7.5 – 12.5 k $\Omega$**

If measured resistance is out of specification, replace the spark plug cap.

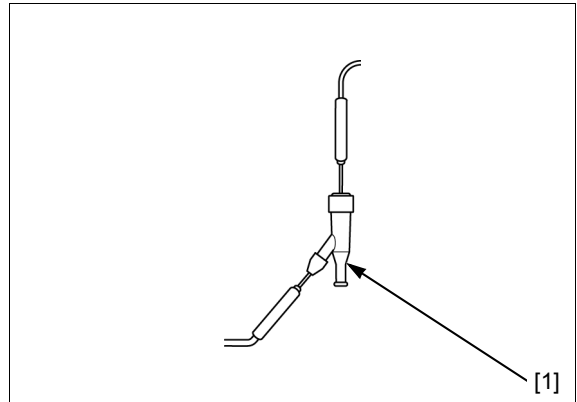

## SPARK TEST

Inspect the following before performing spark test.

- Faulty spark plug
- Loose spark plug cap
- Water in the spark plug cap (Leaking the ignition coil secondary voltage)

Remove the spark plug cap (page 3-12).

Connect a known-good spark plug [1] to the spark plug cap [2] and ground the spark plug to the bolt [3].

Turn the engine stop switch to the "ON" position, pull the recoil starter and check whether sparks jump across the electrode.

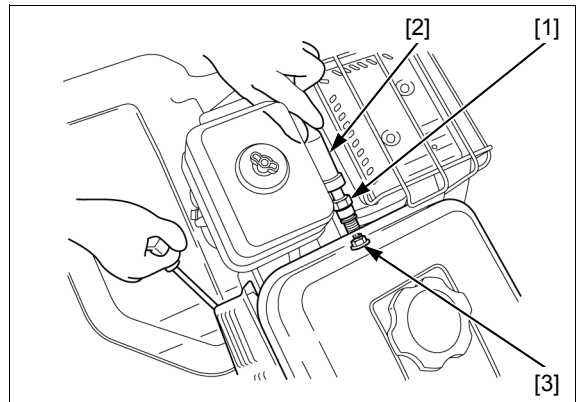

# ENGINE STOP SWITCH REMOVAL/ INSTALLATION

**NOTE:**

- When installation, route the wire harness properly (page 2-7).

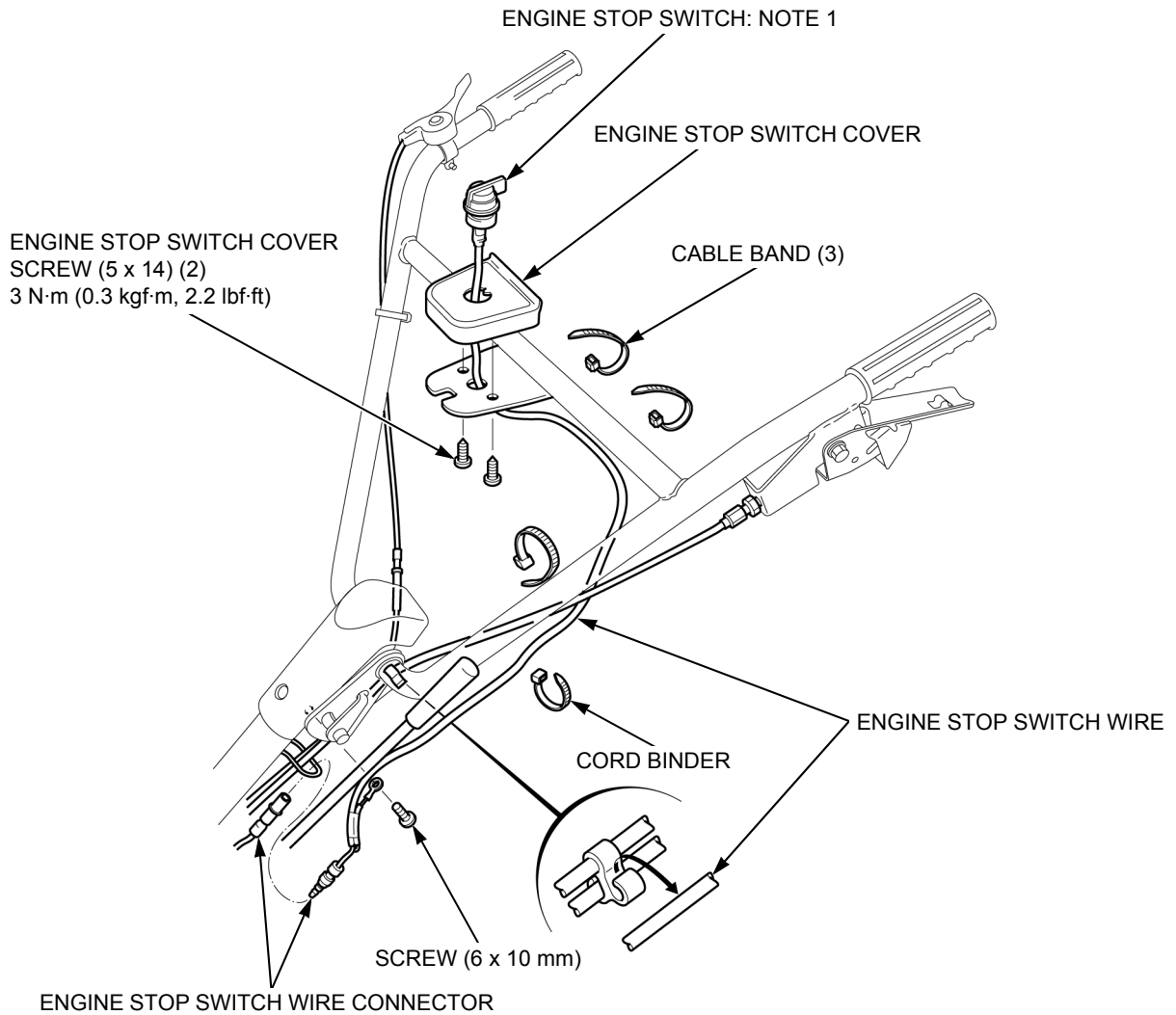

NOTE 1	ENGINE STOP SWITCH INSPECTION	page 7-7
--------	-------------------------------	----------

## ENGINE STOP SWITCH INSPECTION

Check for continuity between the engine stop switch wire connector [1] and ground terminal [2] in each switch position.

Switch position	Continuity
ON	No Continuity
OFF	Continuity

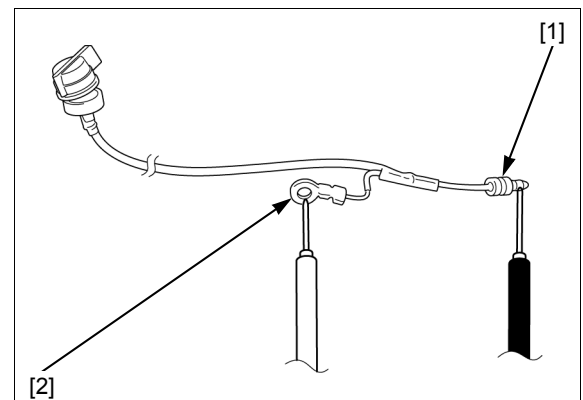

---

**MEMO**

---

# 8. STARTING SYSTEM

---

RECOIL STARTER REMOVAL/  
INSTALLATION .....8-2

RECOIL STARTER INSPECTION.....8-2

RECOIL STARTER DISASSEMBLY/  
ASSEMBLY .....8-3

## STARTING SYSTEM

# RECOIL STARTER REMOVAL/ INSTALLATION

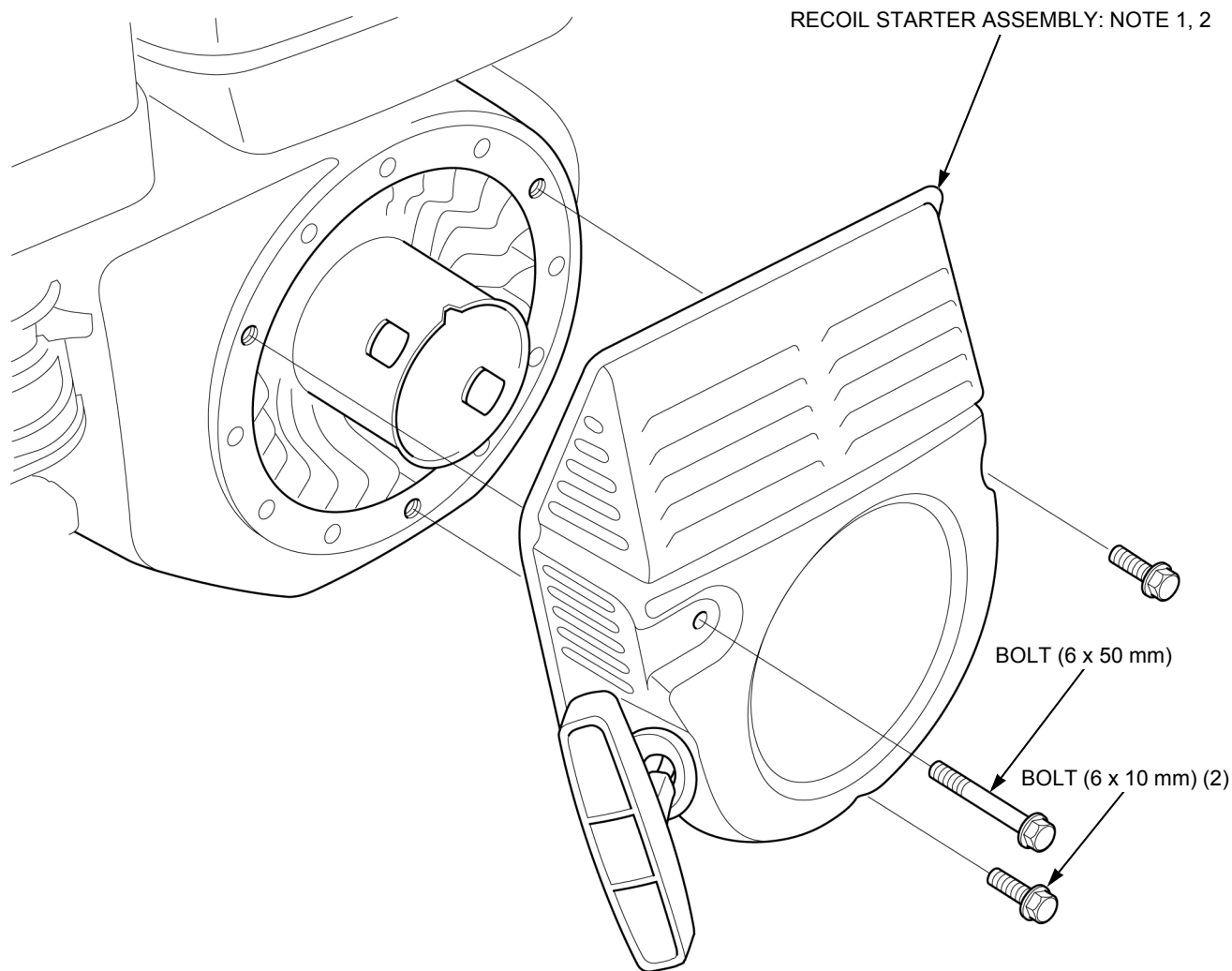

NOTE 1	RECOIL STARTER INSPECTION	page 8-2
NOTE 2	RECOIL STARTER DISASSEMBLY/ASSEMBLY	page 8-3

## RECOIL STARTER INSPECTION

### RECOIL STARTER

Remove the recoil starter (page 8-2).

Check the operation of the two ratchets [1] by pulling the starter rope out several times.

Pull the starter grip [2] until the starter rope [3] is pulled out fully.

Check the rope for fraying or wearing.

Clean the recoil starter cover [4] to remove the dirt and debris.

Install the recoil starter (page 8-2).

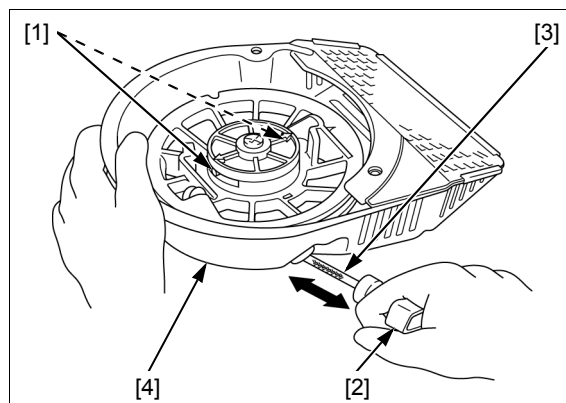

**STARTER PULLEY**

Remove the recoil starter (page 8-2).

Inspect the four square holes [1] of the starter pulley [2] for deformation.

Install the recoil starter (page 8-2).

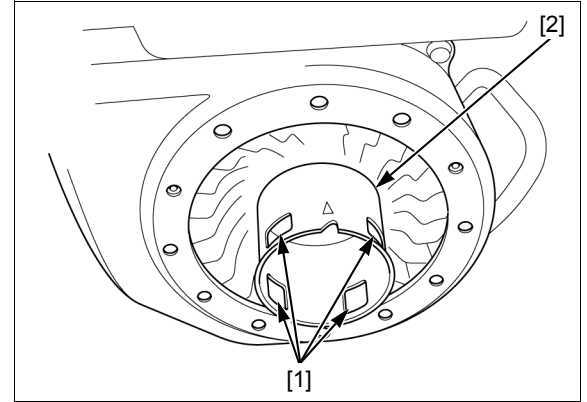

**RECOIL STARTER DISASSEMBLY/ ASSEMBLY**

**DISASSEMBLY**

**⚠ CAUTION**

- Wear gloves and eye protection.
- During disassembly, take care not to allow the return spring to come out.

Remove the recoil starter (page 8-2).

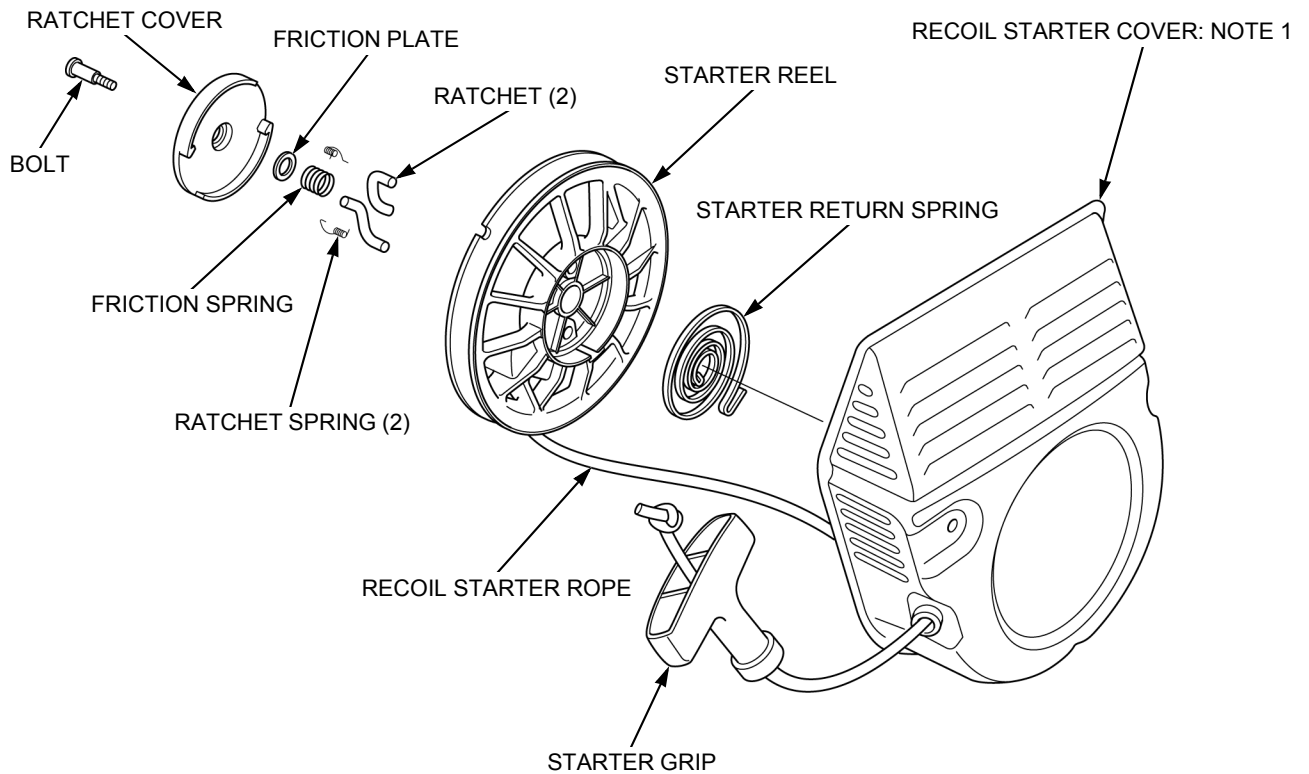

## STARTING SYSTEM

### ASSEMBLY

#### **CAUTION**

- Wear gloves and eye protection.
- During assembly, take care not to allow the return spring to come out.

Pass the recoil starter rope [1] through the hole [2] of the starter reel [3], and then tie the rope as shown.

#### **NOTICE**

- *Before installing the recoil starter rope, check for fray or wear.*

Wind the recoil starter rope onto the starter reel counterclockwise.

Hook the rope to the cut-out [4] of the starter reel.

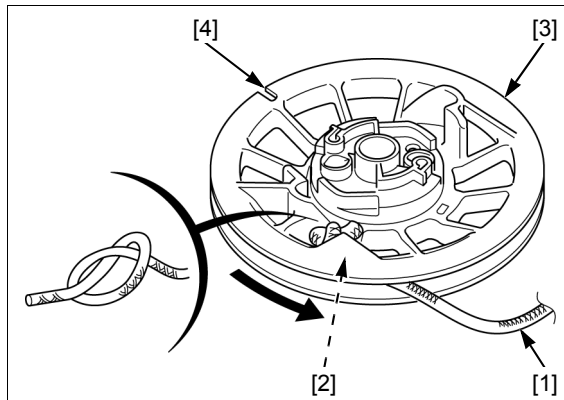

Hook the outer hook [1] of the starter return spring [2] to the groove [3] of the starter reel [4], and then install the starter return spring by winding it.

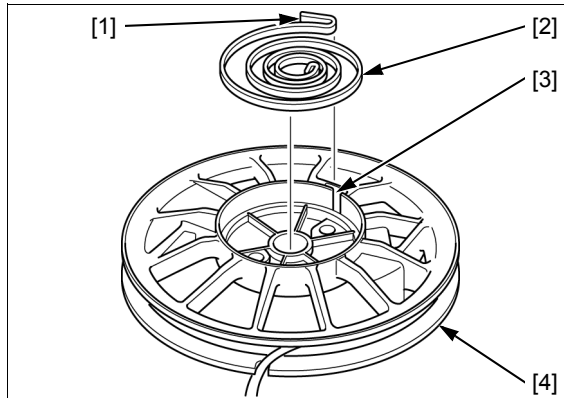

Apply grease to the boss [1] of the recoil starter cover [2].

Set the starter reel [3] to the recoil starter cover by aligning the inner hook [4] of the starter return spring with the boss of the recoil starter cover.

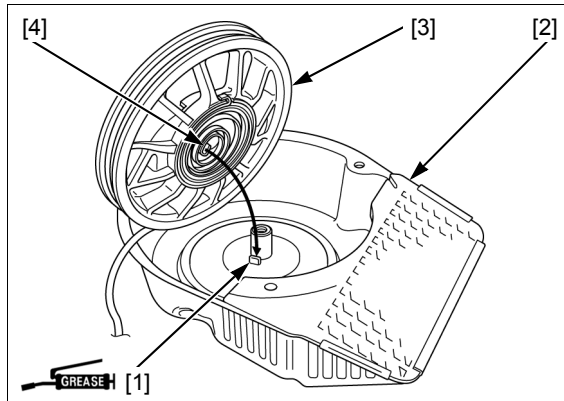

Install the two ratchets [1] and the two ratchet springs [2] to the starter reel [3] as shown.

Apply grease to the friction spring [4] whole surface.

Set the friction spring, friction plate [5] and ratchet cover [6] to the starter reel by aligning the tip of the ratchet with arrow mark [7] on the ratchet cover.

Hold the ratchet cover and tighten the bolt [8] securely.

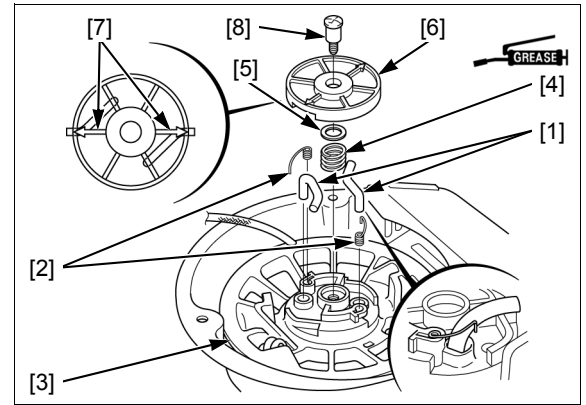

Turn the starter reel [1] 3 full turns counterclockwise to preload the starter return spring.

Be sure to hold the starter reel.

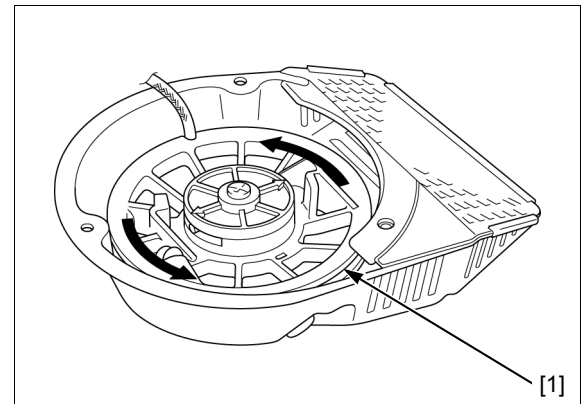

Pass the recoil starter rope [1] through hole [2] of the recoil starter cover, the starter grip [3], and then tie the rope as shown.

Check the recoil starter operation (page 8-2).

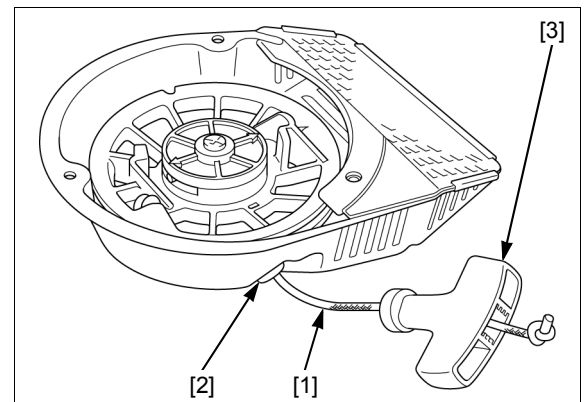

---

**MEMO**

---

MUFFLER REMOVAL/INSTALLATION.....9-2

## MUFFLER

# MUFFLER REMOVAL/INSTALLATION

### ⚠ CAUTION

The engine and muffler become very hot during operation and they remain hot for a while after operation.  
The muffler removal must be made while the engine is cold.

Remove the belt cover stay (page 11-2).

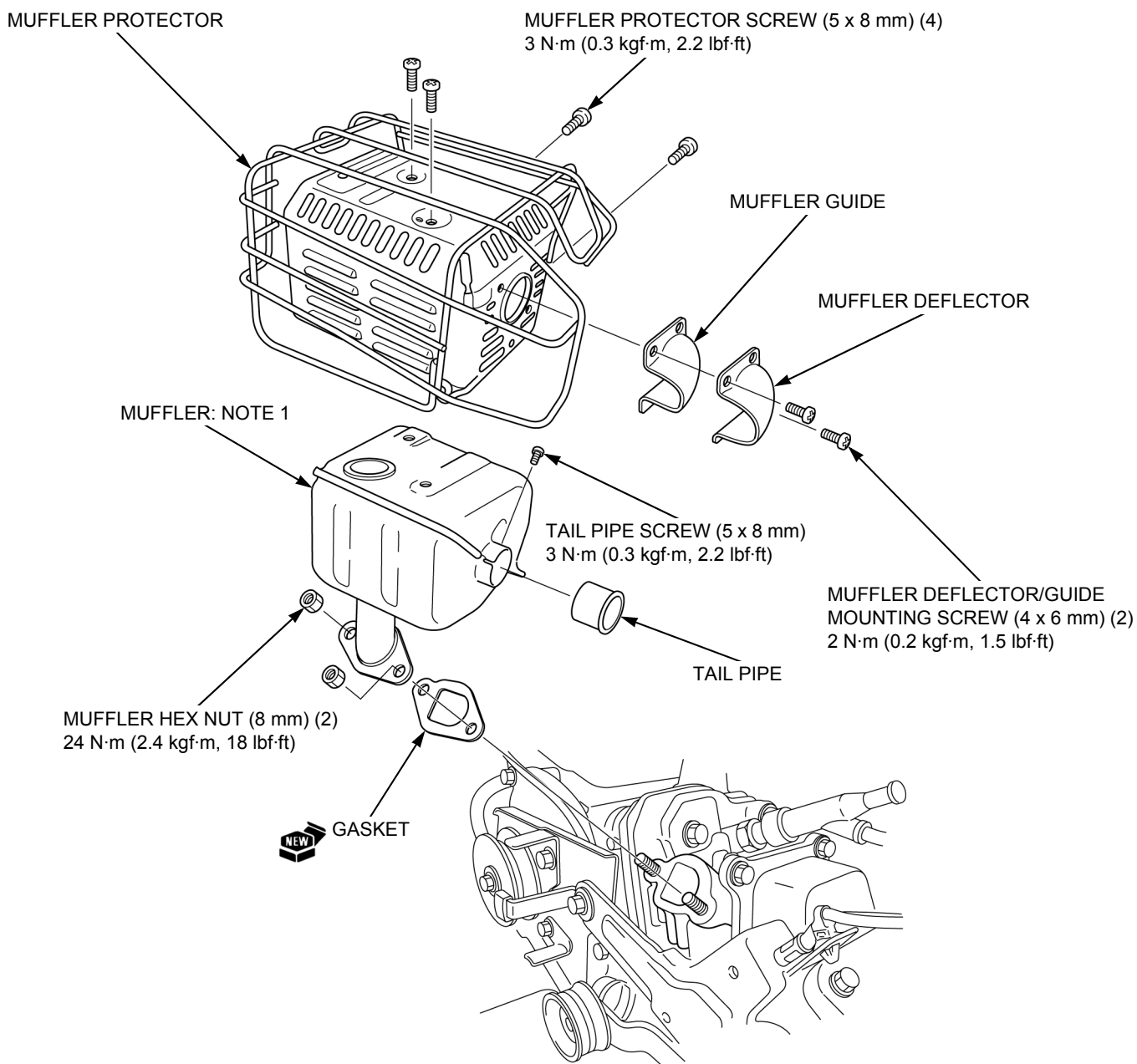

NOTE 1	Before installation, remove the carbon deposits with a plastic hammer.	-
--------	--	---

# 10. ENGINE REMOVAL/INSTALLATION

---

ENGINE REMOVAL/INSTALLATION .....10-2

## ENGINE REMOVAL/INSTALLATION

### ENGINE REMOVAL/INSTALLATION

**NOTE:**

- When installation, route the wire harness properly (page 2-7)

Remove the V-belt, engine stay bolt (8 x 20 mm) and washer (8 mm) (page 11-2).

Remove the air cleaner (page 5-4).

Move the throttle lever to the "LOW" position and disconnect the throttle cable [1] from the control base [2].

After installation, adjust the V-belt tension (page 3-7).

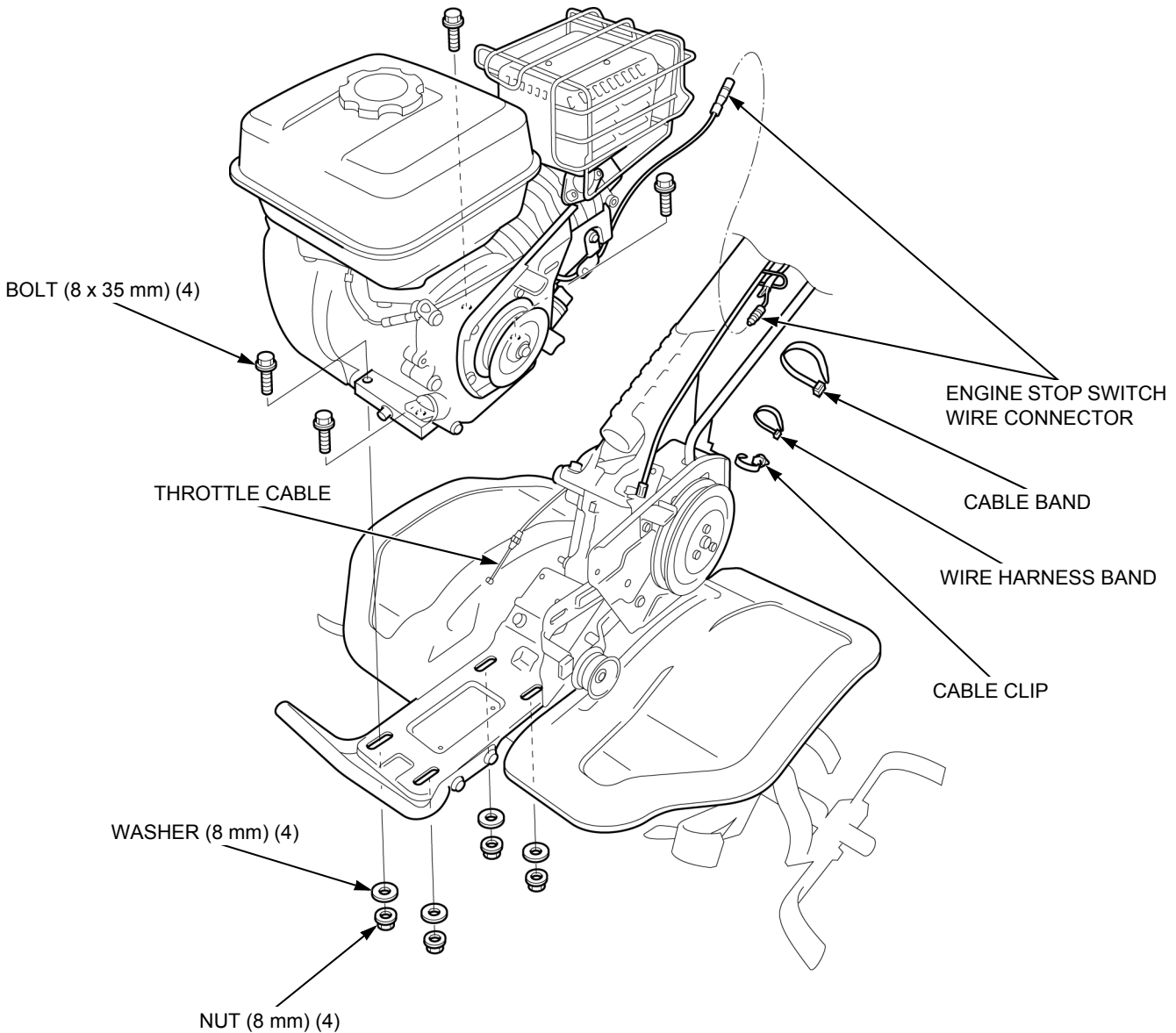
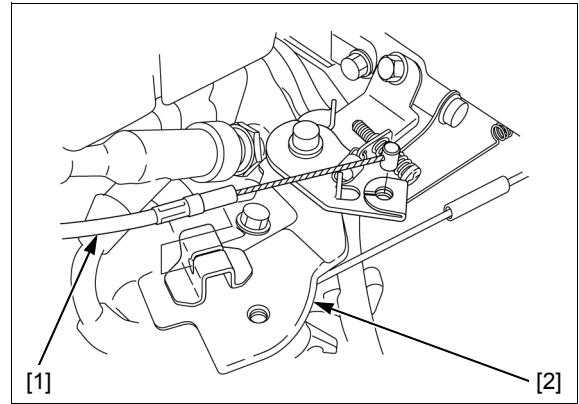

PULLEY/V-BELT REMOVAL/  
INSTALLATION .....11-2

# CLUTCH

## PULLEY/V-BELT REMOVAL/ INSTALLATION

**NOTE:**

- When installation, route the wire harness properly (page 2-7).

After installation, adjust the V-belt tension (page 3-7).

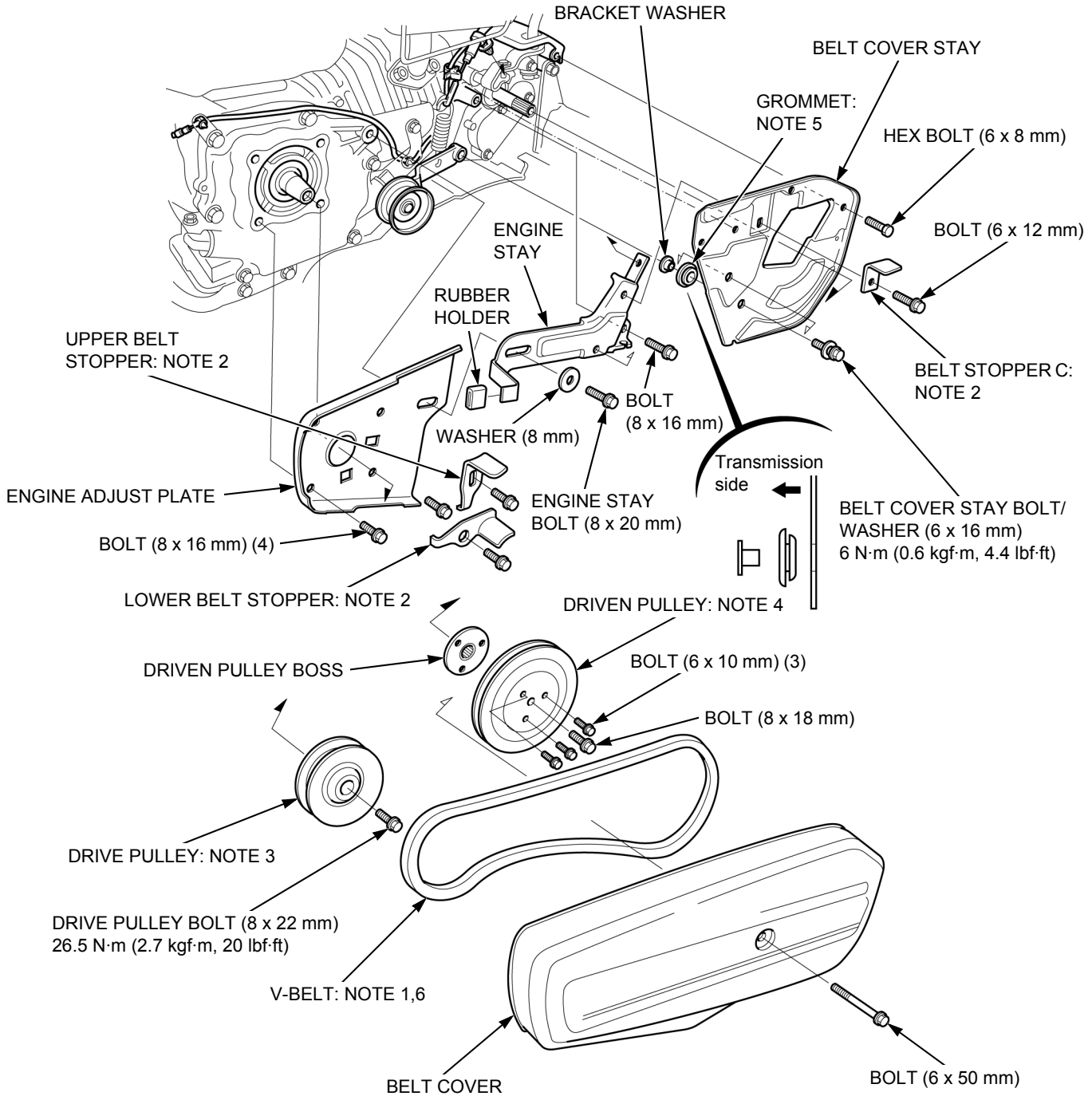

NOTE 1	BELT TENSION ADJUSTMENT	page 3-7
NOTE 2	BELT STOPPER ADJUSTMENT	page 3-9
NOTE 3	DRIVE PULLEY REMOVAL/INSTALLATION	page 11-3
NOTE 4	DRIVEN PULLEY REMOVAL/INSTALLATION	page 11-3
NOTE 5	When reassembly, note the installation direction.	—
NOTE 6	Before installation, check that there is no crack and abnormal wear-out in the belt and replace if necessary.	—

## DRIVE PULLEY REMOVAL/ INSTALLATION

### NOTICE

- Take care not to damage the drive pulley with the strap wrench.

Hold the drive pulley [1] with a commercially available strap wrench [2] and remove the bolt (8 x 22 mm) [3].

Screw in a bolt (14 x 1.5 mm) [4] to remove the drive pulley.

Install the drive pulley and bolt.

Hold the drive pulley with a commercially available strap wrench and tighten the bolt to the specified torque.

**TORQUE: 26.5 N·m (2.7 kgf·m, 2.0 lbf·ft)**

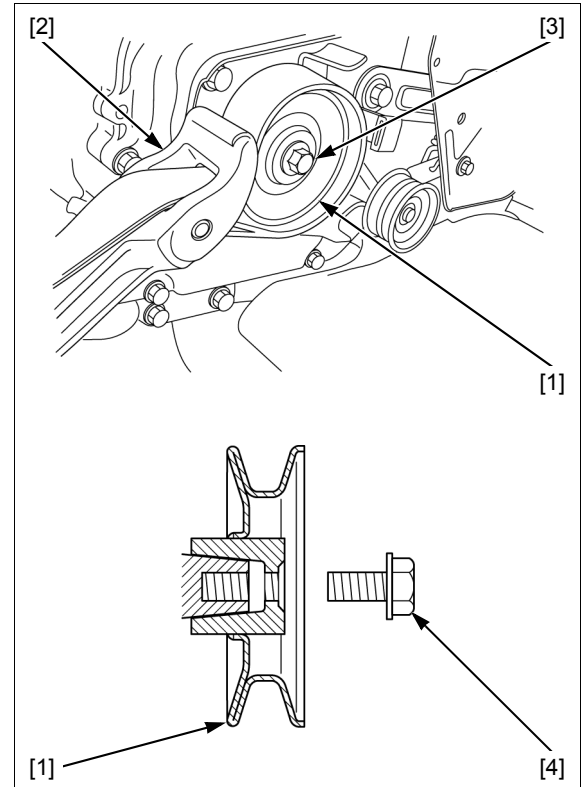

## DRIVEN PULLEY REMOVAL/ INSTALLATION

### NOTICE

- Take care not to damage the driven pulley with the strap wrench.

Hold the driven pulley [1] with a commercially available strap wrench [2] and remove the bolt (8 x 18 mm) [3] and three bolts (6 x 10 mm) [4].

Install the driven pulley and bolts (6 x 10 mm, 8 x 18 mm) through the driven pulley boss [5] as shown.

Hold the driven pulley with a commercially available strap wrench.

Loosely tighten the three bolts (6 x 10 mm) and tighten the bolt (8 x 18 mm) securely.

Tighten the three bolts (6 x 10 mm) securely.

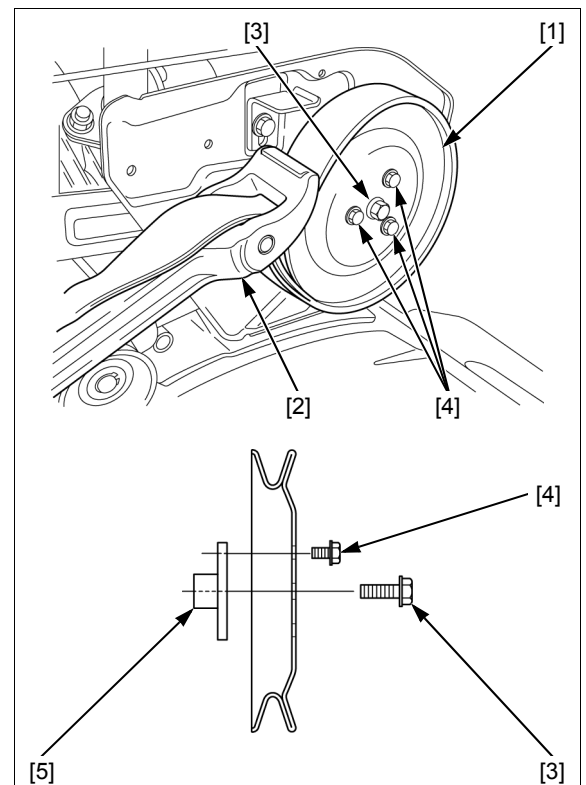

---

**MEMO**

---







# 12. CYLINDER HEAD

---

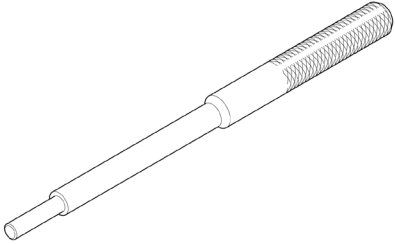
TOOLS.....	12-2	CYLINDER HEAD/VALVES INSPECTION.....	12-5
CYLINDER HEAD REMOVAL/ INSTALLATION.....	12-3	VALVE GUIDE REPLACEMENT .....	12-8
CYLINDER HEAD DISASSEMBLY/ ASSEMBLY .....	12-4	VALVE GUIDE REAMING .....	12-9
		VALVE SEAT RECONDITIONING.....	12-10

# CYLINDER HEAD

## TOOLS

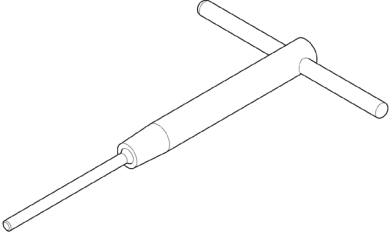
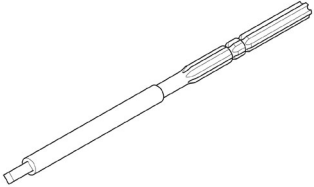
<p>Valve guide driver, 5.5 mm 07742-0010100</p> 	<p>Seat cutter, 27.5 mm (45° IN) 07780-0010200</p> 	<p>Seat cutter, 24.5 mm (45° EX) 07780-0010100</p> 
<p>Flat cutter, 28 mm (32° IN) 07780-0012100</p> 	<p>Flat cutter, 25 mm (32° EX) 07780-0012000</p> 	<p>Interior cutter, 30 mm (60° IN/EX) 07780-0014000</p> 
<p>Cutter holder, 5.5 mm 07781-0010101</p> 	<p>Valve guide reamer, 5.510 mm 07984-2000001</p> 	

# CYLINDER HEAD REMOVAL/ INSTALLATION

Set the piston at top dead center of the cylinder compression stroke (page 3-13).

Remove the following:

- Engine (page 10-2)
- Control base/governor arm (page 6-2)
- Carburetor (page 5-5)
- Muffler (page 9-2)

After installation, perform the following:

- Check the valve clearance, and if necessary, adjust the clearance (page 3-13).
- Measure the cylinder compression (page 12-5).

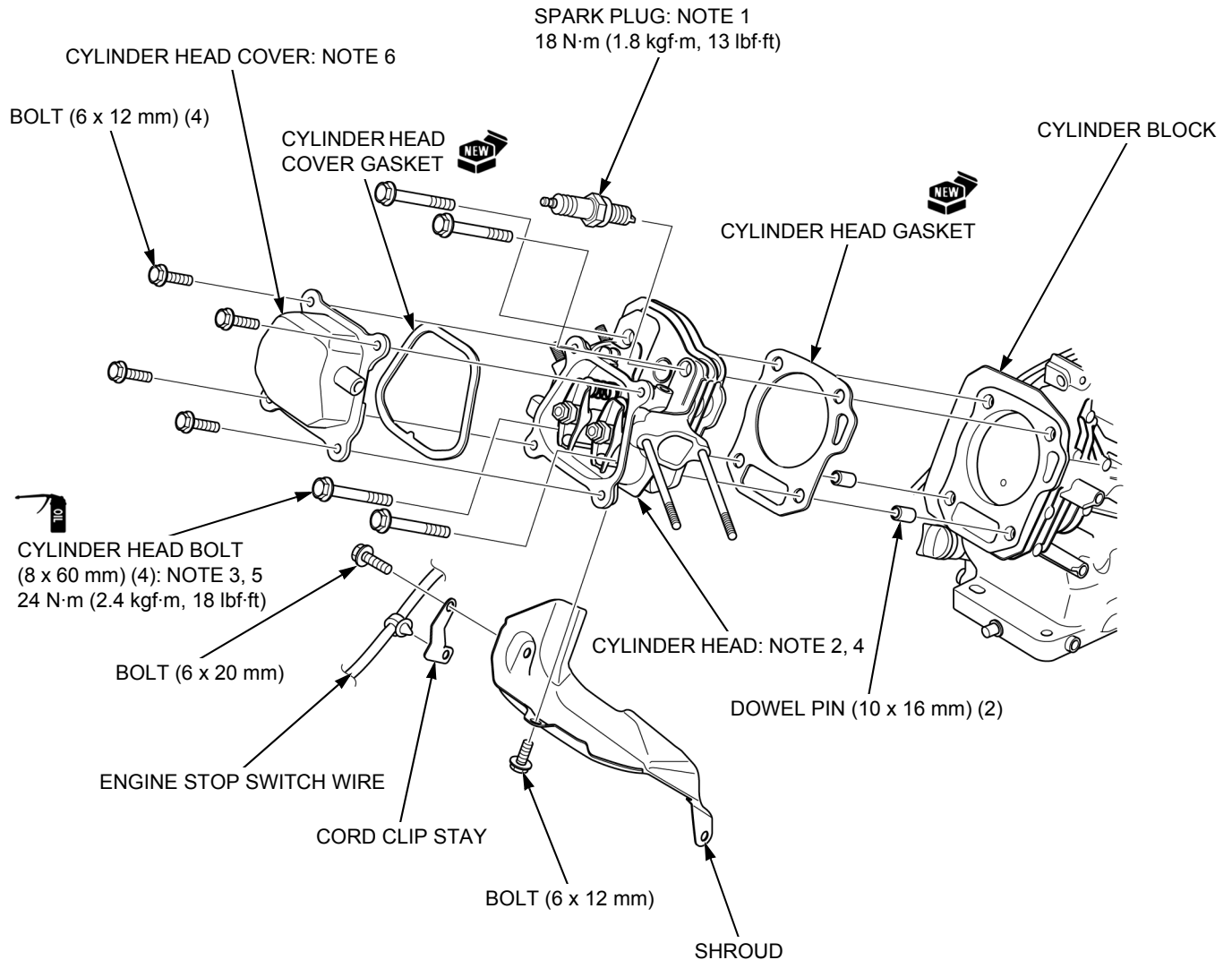

NOTE 1	SPARK PLUG INSPECTION/ADJUSTMENT	page 3-12
NOTE 2	CYLINDER HEAD DISASSEMBLY/ASSEMBLY	page 12-4
NOTE 3	When removal/installation, loosen or tighten the bolts in a crisscross pattern in 2-3 steps.	-
NOTE 4	Before installation, remove any carbon deposits from the combustion chamber and inspect the valve seats.	-
NOTE 5	When reassembly, apply engine oil to the threads and seating surface.	-
NOTE 6	<ul style="list-style-type: none"> <li>• When removing, pry off slowly at each corner of the head cover.</li> <li>• Using too much force can deform the cylinder head cover. The cylinder head cover must be replaced if it is deformed.</li> </ul>	-

## CYLINDER HEAD

# CYLINDER HEAD DISASSEMBLY/ ASSEMBLY

Remove the cylinder head (page 12-3).

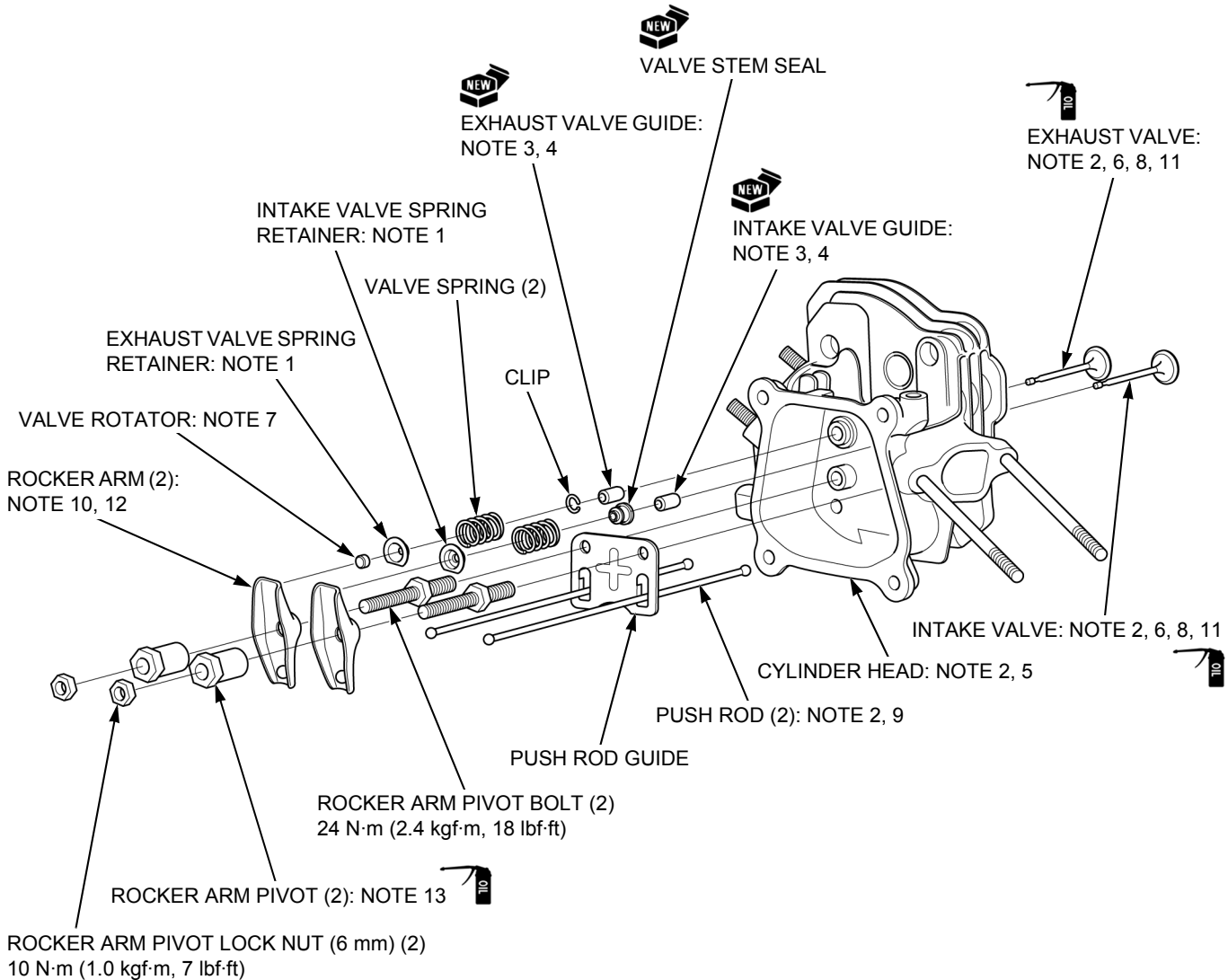

NOTE 1	VALVE SPRING RETAINER REMOVAL/INSTALLATION	page 12-5
NOTE 2	CYLINDER HEAD/VALVES INSPECTION	page 12-5
NOTE 3	VALVE GUIDE REPLACEMENT	page 12-8
NOTE 4	VALVE GUIDE REAMING	page 12-9
NOTE 5	VALVE SEAT RECONDITIONING	page 12-10
NOTE 6	Do not interchange the valves. VALVE HEAD DIAMETER: IN: 25 mm (0.98 in) EX: 24 mm (0.94 in)	—
NOTE 7	If the valve rotator is not installed, the exhaust valve may drop into the cylinder when starting the engine.	—
NOTE 8	Before installation, remove carbon deposits and inspect the valve.	—
NOTE 9	When reassembly, check both ends for wear and check the rod for straightness. Be sure the rod ends are firmly seated in the lifters.	—
NOTE 10	Before installation, check for wear on the pivot bolt, push rod and rocker arm pivot.	—
NOTE 11	When reassembly, apply engine oil to the valve stem sliding surface and stem end.	—
NOTE 12	When reassembly, apply engine oil to the tappet surface and pivot.	—
NOTE 13	When reassembly, apply engine oil to the threads and pivot.	—

## VALVE SPRING RETAINER REMOVAL/ INSTALLATION

### NOTE:

- Do not remove the valve spring retainers while the cylinder head is installed to cylinder block, or the valve will drop into the cylinder.

### REMOVAL

Push down and slide the valve spring retainer [1] to the side so that the valve stem slips through the hole at the side of the valve spring retainer.

### INSTALLATION

Hold the valve so that the valve will not drop.

Push down and slide the valve spring retainer [1] to the side so that the valve spring retainer is hooked the valve spring groove at the side of the valve spring retainer.

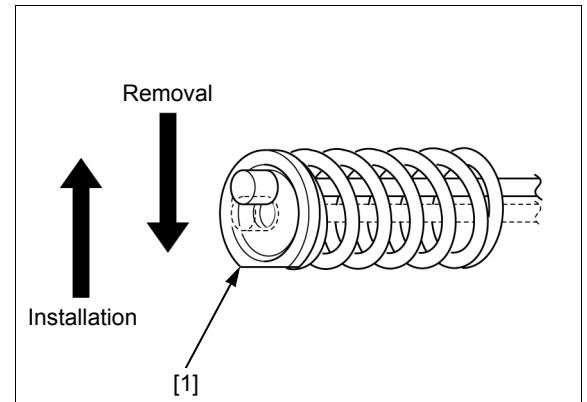

## CYLINDER HEAD/VALVES INSPECTION

### CYLINDER COMPRESSION CHECK

Remove the spark plug (page 3-12).

Attach a commercially available compression gauge [1] to the spark plug hole.

Pull the starter grip [2] forcefully to measure stable cylinder compression.

### CYLINDER COMPRESSION:

**0.59 MPa (6.0 kgf/cm<sup>2</sup>, 86 psi)/600 min<sup>-1</sup> (rpm)**

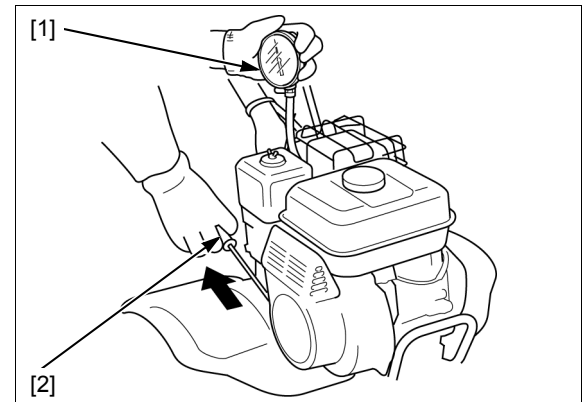

### CYLINDER HEAD WARPAGE

Clear off any gasket material from the cylinder head surface.

Check the spark plug hole and valve areas for cracks.

Check the cylinder head warpage using a straightedge [1] and thickness gauge [2].

### SERVICE LIMIT: 0.10 mm (0.004 in)

If the measurement is more than the service limit, replace the cylinder head (page 12-3).

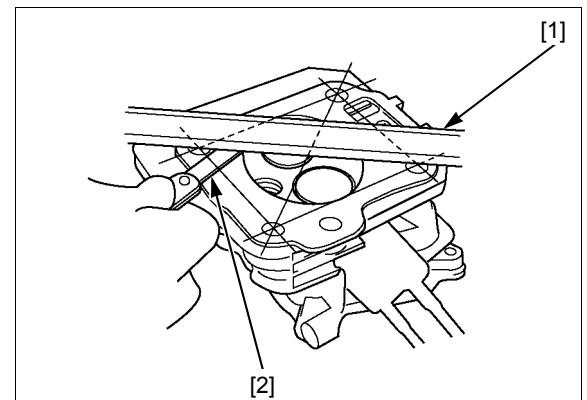

## CYLINDER HEAD

### VALVE SEAT WIDTH

Inspect each valve for face irregularities.

If necessary, replace the valve (page 12-4).

Apply a light coat of Prussian Blue or erasable felt-tipped marker ink to each valve seat.

Insert the valve, and snap it using a lapping tool [1] closed against its seat several times.

Be sure the valve does not rotate on the seat.

The transferred marking compound will show any area of the valve face that is not concentric.

Measure the valve seat width of the cylinder head.

**STANDARD:** 0.7 – 0.9 mm (0.03 – 0.04 in)

**SERVICE LIMIT:** 2.0 mm (0.08 in)

If the measurement is more than the service limit, recondition the valve seat (page 12-10).

Check whether the valve seat contact area of the valve is too high.

If the valve seat is too high or too low, recondition the valve seat (page 12-10).

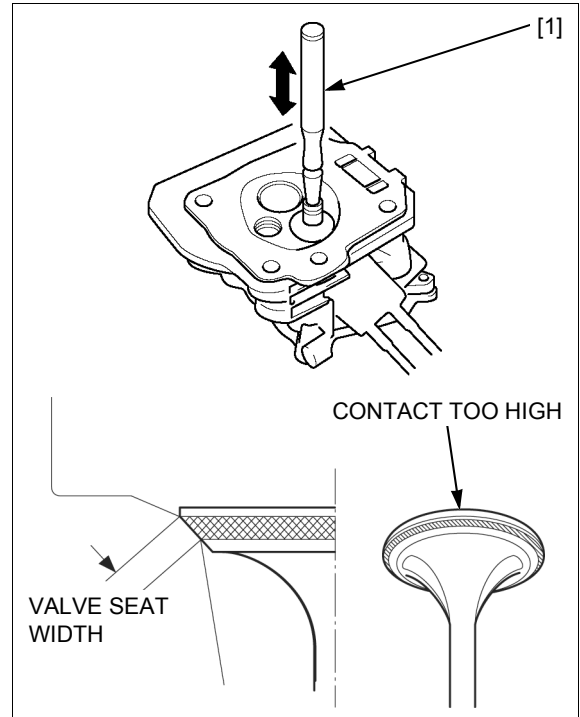

### VALVE GUIDE I.D.

Ream the valve guide [1] to remove any carbon deposits before measuring.

**TOOL:**

**Valve guide reamer, 5.510 mm [2]07984-2000001**

#### NOTICE

- Turn the special tool (Valve guide reamer) clockwise, never counterclockwise.
- Continue to rotate the special tool while removing it from the valve guide.

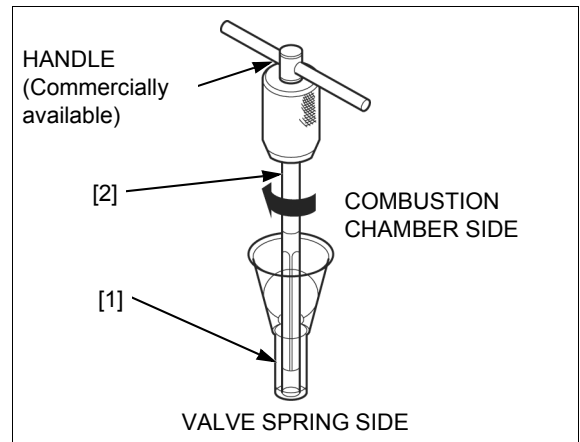

Measure and record each valve guide I.D.

**STANDARD:** IN/EX: 5.500 – 5.512 mm  
(0.2165 – 0.2170 in)

**SERVICE LIMIT:** IN/EX: 5.572 mm (0.2194 in)

If the measured valve guide I.D. is more than the service limit, replace the valve guide (page 12-8).

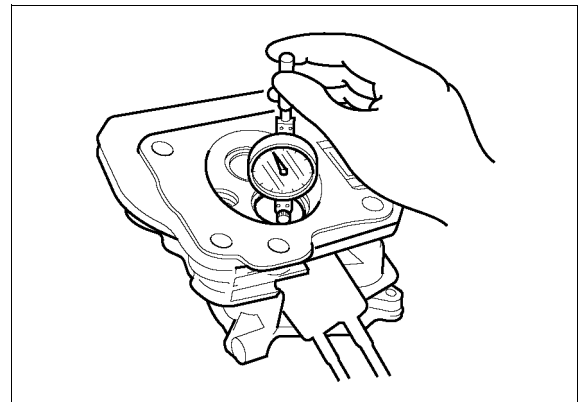

**VALVE FACE**

Inspect each valve for face irregularities.

If necessary, replace the valve (page 12-4).

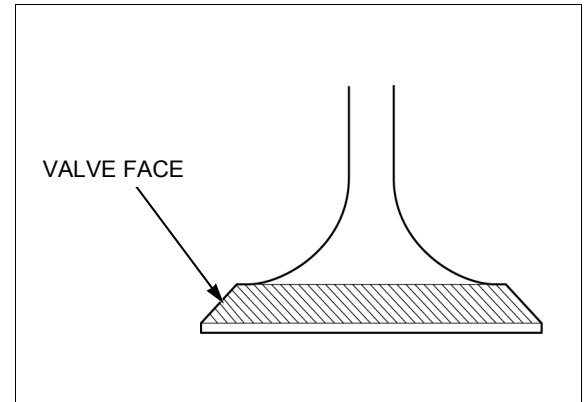
**VALVE STEM O.D.**

Inspect each valve for bending or abnormal stem wear.

If necessary, replace the valve (page 12-4).

Measure and record each valve stem O.D.

**STANDARD:**

**IN:** 5.468 – 5.480 mm (0.2153 – 0.2157 in)

**EX:** 5.425 – 5.440 mm (0.2136 – 0.2142 in)

**SERVICE LIMIT:**

**IN:** 5.318 mm (0.2094 in)

**EX:** 5.275 mm (0.2077 in)

If the measurement is less than the service limit, replace the valve (page 12-4).

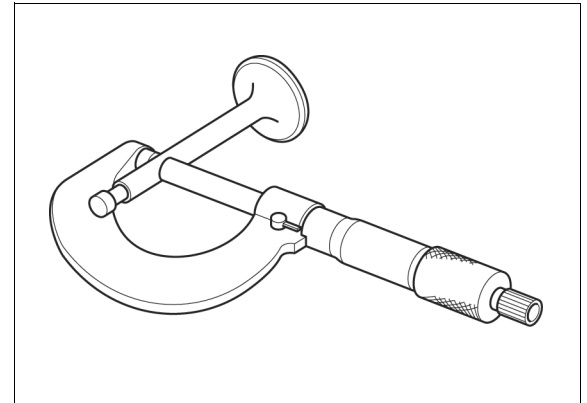
**GUIDE-TO-STEM CLEARANCE**

Subtract each valve stem O.D. from the corresponding guide I.D. to obtain the stem-to-guide clearance.

**STANDARD:**

**IN:** 0.020 – 0.044 mm (0.0008 – 0.0017 in)

**EX:** 0.060 – 0.087 mm (0.0024 – 0.0034 in)

**SERVICE LIMIT:**

**IN:** 0.10 mm (0.004 in)

**EX:** 0.12 mm (0.005 in)

If the calculated clearance is more than the service limit, replace the following:

- Valve (page 12-4)
- Valve guide (page 12-8)

**VALVE SPRING FREE LENGTH**

Measure the valve spring free length.

**STANDARD:** 30.5 mm (1.20 in)

**SERVICE LIMIT:** 29.0 mm (1.14 in)

If the measured length is less than the service limit, replace the valve spring (page 12-4).

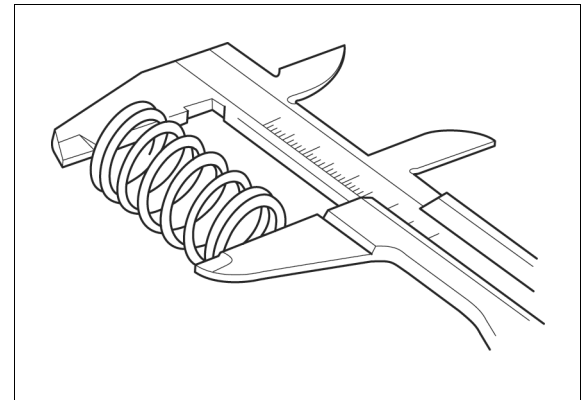

## CYLINDER HEAD

### VALVE SPRING PERPENDICULARITY

Measure the valve spring perpendicularity.

**SERVICE LIMIT: 1.5°**

If the measured perpendicularity is more than the service limit, replace the valve spring (page 12-4).

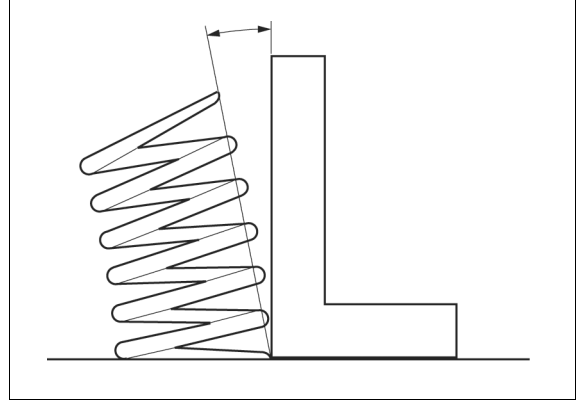

### PUSH ROD RUNOUT

Check both ends of the push rod for wear.

Check the push rod for straightness.

If necessary, replace the push rod (page 12-4).

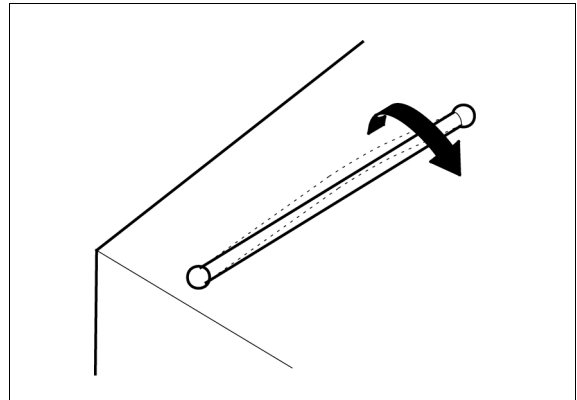

## VALVE GUIDE REPLACEMENT

Chill the replacement valve guides in the freezer section of a refrigerator for about an hour.

Use a hot plate or oven to heat the cylinder head evenly to 150°C (302°F).

### CAUTION

To avoid burns, use heavy gloves when handling the heated cylinder head.

### NOTICE

- Do not use a torch to heat the cylinder head; warpage of the cylinder head may result.
- Do not get the cylinder head hotter than 150°C (302°F); excessive heat may loosen the valve seat.

Remove the heated cylinder head from the hot plate and support it with wooden blocks.

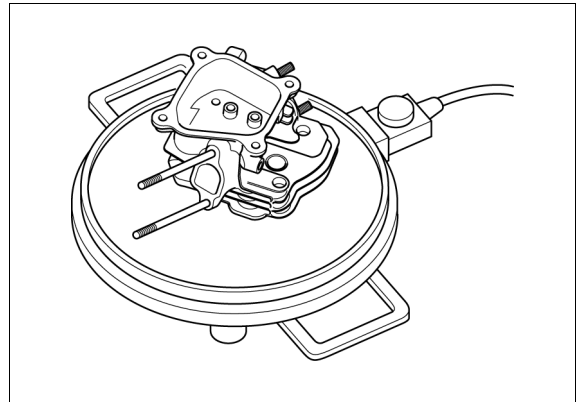

Drive the valve guides [1] out of the cylinder head from the combustion chamber side.

**TOOL:**  
**Valve guide driver, 5.5 mm [2] 07742-0010100**

**NOTICE**

- *When driving the valve guides out, be careful not to damage the cylinder head.*

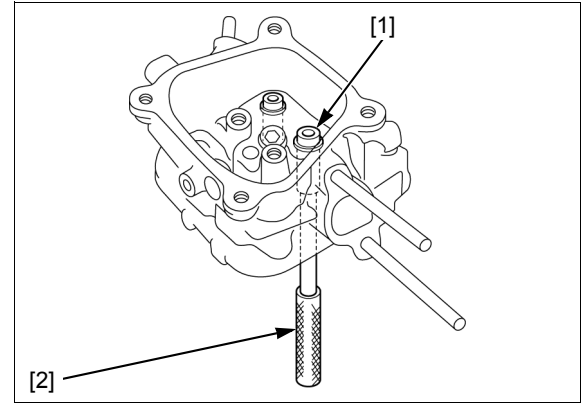

Remove new valve guides from the refrigerator one at a time as needed.

Drive the exhaust valve guide [1] until the valve guide clip [2] is fully seated as shown from the valve spring side of the cylinder head.

**TOOL:**  
**Valve guide driver, 5.5 mm [3] 07742-0010100**

Drive the intake valve guide [4] to the specified height (measured from the end of the valve guide to the cylinder head as shown) from the valve spring side of the cylinder head.

**TOOL:**  
**Valve guide driver, 5.5 mm 07742-0010100**

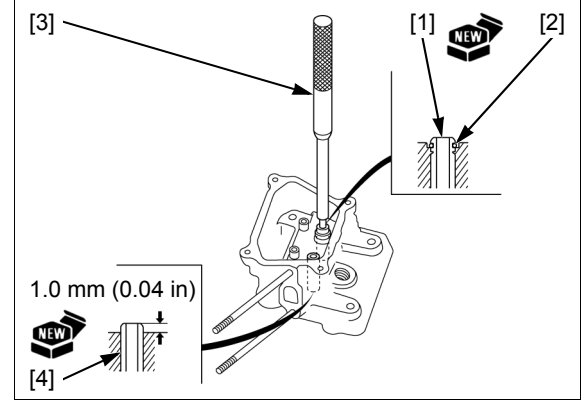

**INTAKE VALVE GUIDE INSTALLATION HEIGHT:**  
**1.0 mm (0.04 in)**

After installing the valve guide, check the guide for damage.

Replace the valve guide if damaged.

Let the cylinder head cool to room temperature.

Ream the valve guide (page 12-9).

**VALVE GUIDE REAMING**

For best results, be sure the cylinder head is at room temperature before reaming valve guides.

Coat the reamer and valve guide with cutting oil.

**TOOL:**  
**Valve guide reamer, 5.510 mm [1]07984-2000001**

Rotate the reamer clockwise through the valve guide the full length of the reamer.

**NOTICE**

- *Turn the special tool (valve guide reamer) clockwise, never counterclockwise.*
- *Continue to rotate the special tool while removing it from the valve guide.*
- *Thoroughly clean the cylinder head to remove any cutting residue.*

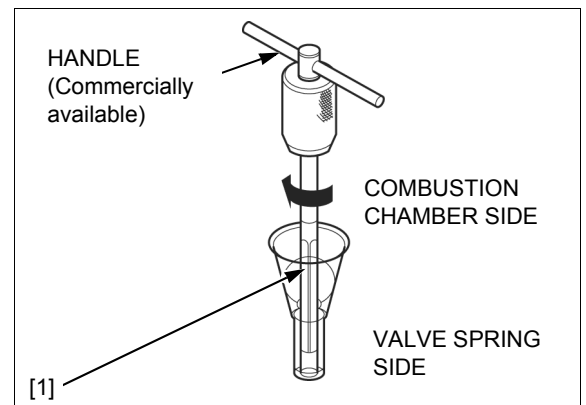

## CYLINDER HEAD

Check the valve guide bore; it should be straight, round and centered in the valve guide. Insert the valve and check operation.

If the valve does not operate smoothly, the guide may have been bent during installation.

Replace the valve guide if it is bent or damaged.

Check the valve guide-to-stem clearance.

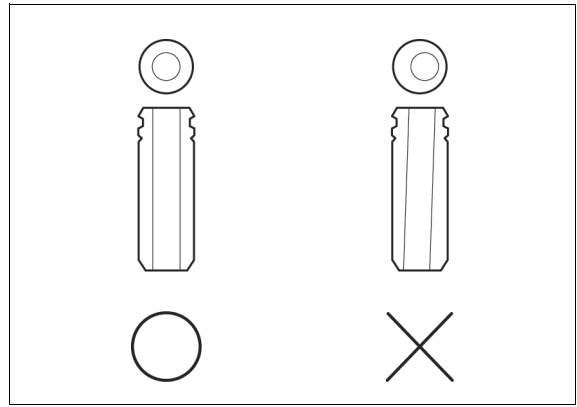

## VALVE SEAT RECONDITIONING

Check the valve seat width (page 12-6).

Valve seat cutters [1]/grinder or equivalent valve seat refacing equipment is recommended to correct a worn valve seat.

### NOTICE

- Turn the cutter clockwise, never counterclockwise.
- Continue to rotate the cutter while removing it from the valve seat.

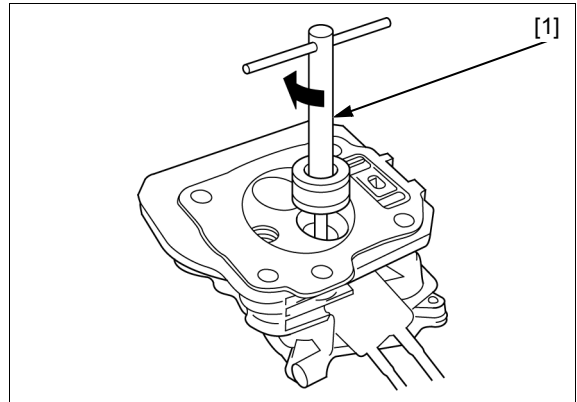

The 32° cutter removes material from the top edge (contact too high).

**TOOLS:**

- Cutter holder, 5.5 mm** 07781-0010101
- Flat cutter, 28 mm (32° IN)** 07780-0012100
- Flat cutter, 25 mm (32° EX)** 07780-0012000

The 60° cutter removes material from the bottom edge (contact too low).

**TOOLS:**

- Cutter holder, 5.5 mm** 07781-0010101
- Interior cutter, 30 mm (60° IN/EX)** 07780-0014000

Be sure that the width of the finished valve seat is within specification.

- STANDARD:** 0.7 – 0.9 mm (0.03 – 0.04 in)
- SERVICE LIMIT:** 2.0 mm (0.08 in)

Make a light pass with the 45° cutter to remove any possible burrs at the edge of the seat.

**TOOLS:**

- Cutter holder, 5.5 mm** 07781-0010101
- Seat cutter, 27.5 mm (45° IN)** 07780-0010200
- Seat cutter, 24.5 mm (45° EX)** 07780-0010100

After resurfacing the seats, inspect for even valve seating.

Apply Prussian Blue compound or erasable felt-tipped marker ink to the valve seat. Insert the valve, and snap it closed against its seat several times. Be sure the valve does not rotate on the seat.

The seating surface, as shown by the transferred marking compound, should have good contact all the way around.

Thoroughly clean the cylinder head to remove any cutting residual.

Lap the valves into their seats, using a commercially available lapping tool [1] and lapping compound.

After lapping, wash all residual compound off the cylinder head and valve.

**NOTICE**

- Do not push the valve against the seat with force during lapping. Apply a light pass with the lapping tool.
- Avoid lapping the valve in the same position as it causes uneven wear. Lap the valve by turning the lapping tool slowly.
- Take care not to allow the lapping compound to enter the gap between the stem and guide.

Adjust the valve clearance after assembly (page 3-13).

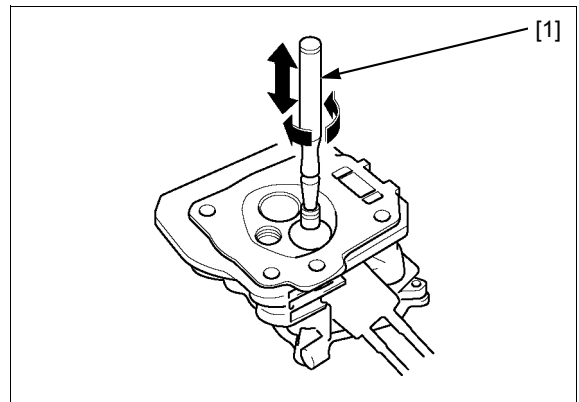
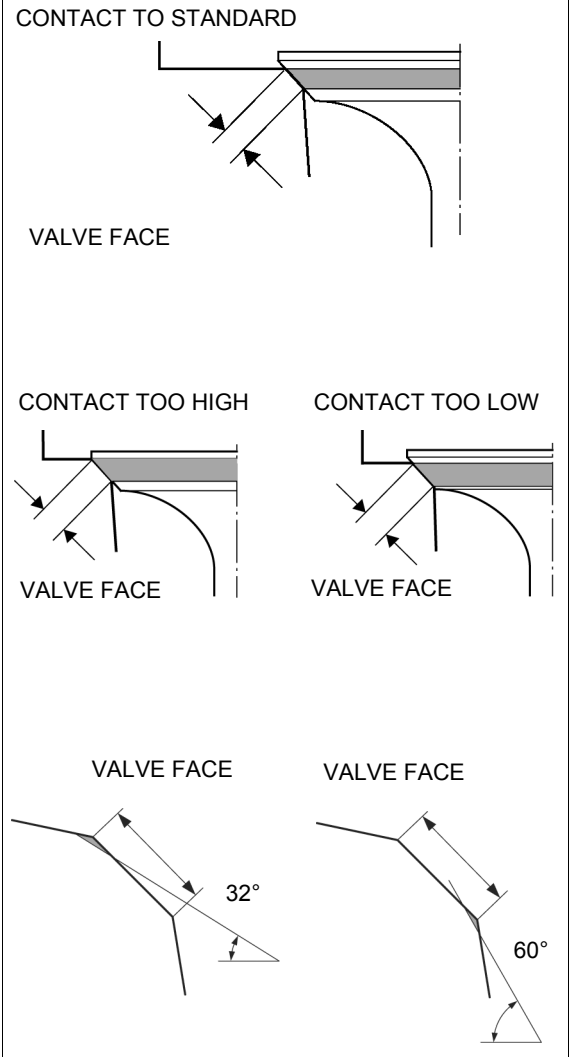

---

**MEMO**

---

# 13. CYLINDER BLOCK

---

TOOLS.....	13-2	CRANKCASE COVER/CYLINDER BLOCK/ PISTON/CONNECTING ROD/CRANKSHAFT/ CAMSHAFT INSPECTION.....	13-7
CRANKCASE COVER/CRANKSHAFT/ CAMSHAFT/PISTON REMOVAL/ INSTALLATION.....	13-3	CRANKSHAFT BEARING/OIL SEAL REPLACEMENT .....	13-13
PISTON DISASSEMBLY/ASSEMBLY.....	13-5		

## CYLINDER BLOCK

### TOOLS

Attachment, 37 x 40 mm  
07746-0010200



Attachment, 52 x 55 mm  
07746-0010400

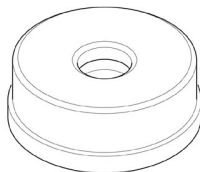

Pilot, 25 mm  
07746-0040600



Driver  
07749-0010000

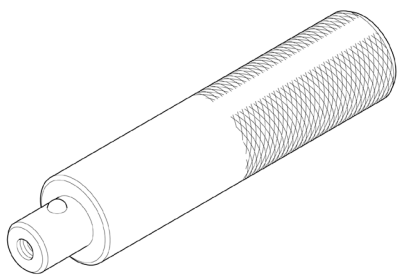

# CRANKCASE COVER/CRANKSHAFT/ CAMSHAFT/PISTON REMOVAL/ INSTALLATION

Drain the engine oil (page 3-4).  
Remove the cylinder head (page 12-3).

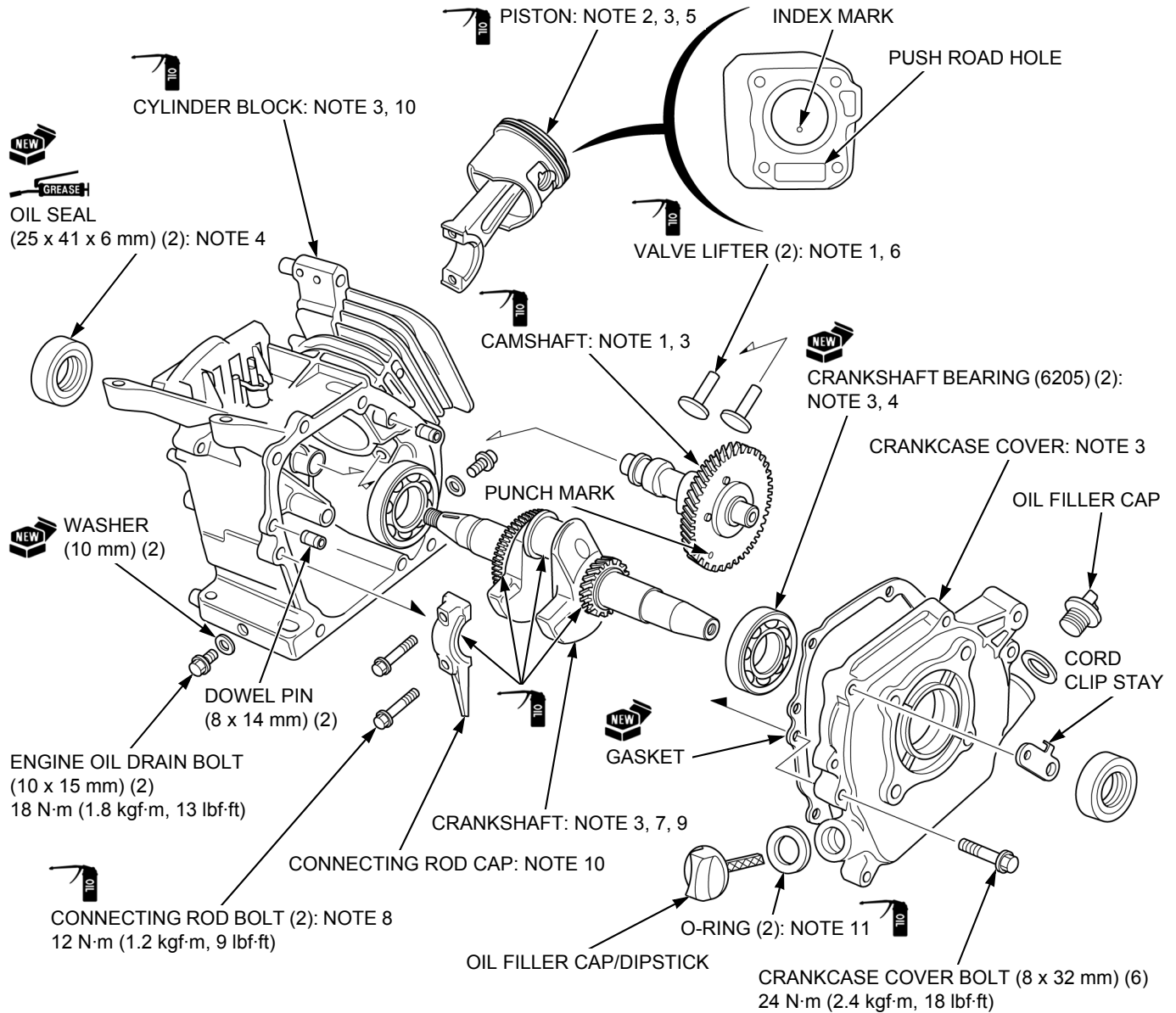

NOTE 1	CAMSHAFT INSTALLATION	page 13-4
NOTE 2	PISTON DISASSEMBLY/ASSEMBLY	page 13-5
NOTE 3	CRANKCASE COVER/CYLINDER BLOCK/PISTON/CONNECTING ROD/ CRANKSHAFT/CAMSHAFT INSPECTION	page 13-7
NOTE 4	CRANKSHAFT BEARING/OIL SEAL REPLACEMENT	page 13-13
NOTE 5	When reassembly, install with the index mark toward the push rod hole.	-
NOTE 6	When disassembly, mark so that the IN and EX sides can be distinguished.	-
NOTE 7	When reassembly, push in until the bearing touches the crankcase. Be careful not to damage the oil seal.	-
NOTE 8	When reassembly, apply engine oil to the threads and seating surface.	-
NOTE 9	When reassembly, apply engine oil to the crankpin and gears.	-
NOTE 10	When reassembly, apply engine oil to the inner surface.	-
NOTE 11	When reassembly, apply engine oil to the whole surface.	-

### CAMSHAFT INSTALLATION

NOTE:

- Install the valve lifters [1] immediately before installing the camshaft [2].

Apply engine oil to the two valve lifters slipper surface, stem and stem end.

Install the valve lifters to the cylinder block [3].

Apply engine oil to the camshaft cam profile and journal.

#### NOTICE

- *When new camshaft, apply molybdenum oil solution (mixture of the engine oil and molybdenum grease in a ratio of 1:1) to the cam profile.*

Install the camshaft to the cylinder block by aligning the punch marks [4] of the camshaft and timing gear [5] of the crankshaft as shown.

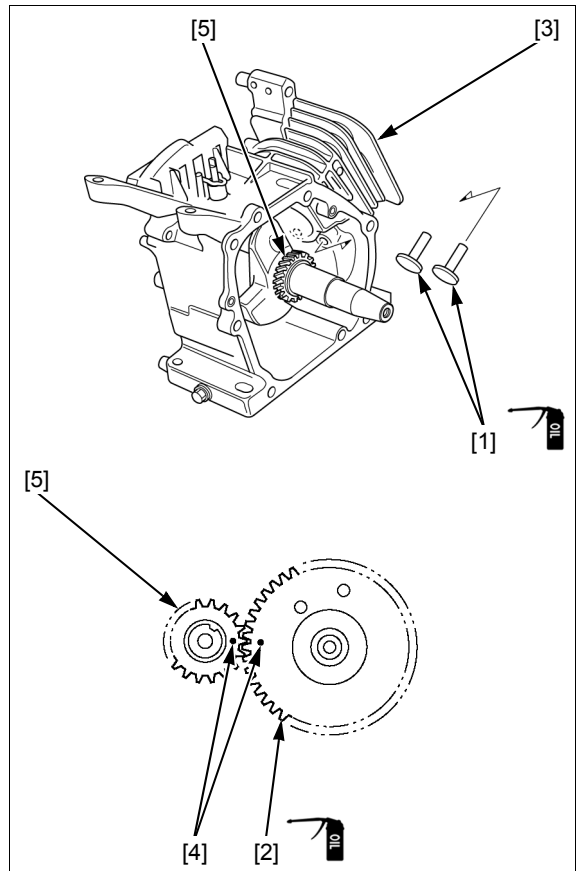

# PISTON DISASSEMBLY/ASSEMBLY

Remove the piston (page 13-3).

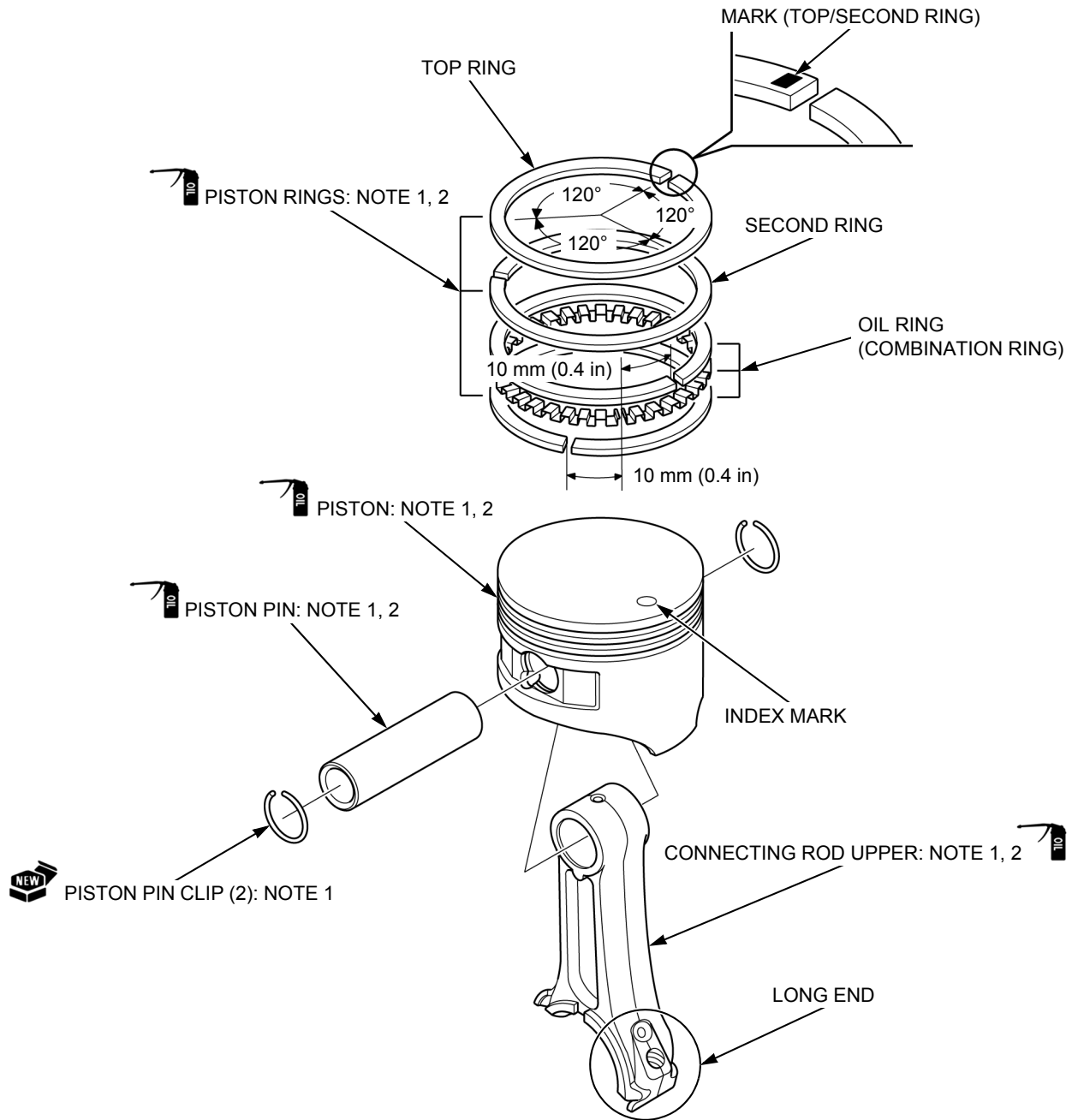

NOTE 1	PISTON ASSEMBLY	page 13-6
NOTE 2	CRANKCASE COVER/CYLINDER BLOCK/PISTON/CONNECTING ROD/ CRANKSHAFT/CAMSHAFT INSPECTION	page 13-7

# CYLINDER BLOCK

## PISTON ASSEMBLY

Apply engine oil to the piston rings [1] whole surface.

*Be careful not to damage the piston and rings.*

Carefully install the top ring [2] and second ring [3] into the piston ring grooves [4] with the maker mark [5] side facing up.

Carefully install the oil ring [6] into the piston ring groove.

Stagger the piston ring end gaps 120° apart from each other.

Stagger the side rail end gaps as shown.

### NOTE:

- Do not confuse the top and second rings.
- To install the oil ring, install the spacer [7] first, then install the side rails [8].

After installation, the piston rings should be free to rotate in the groove.

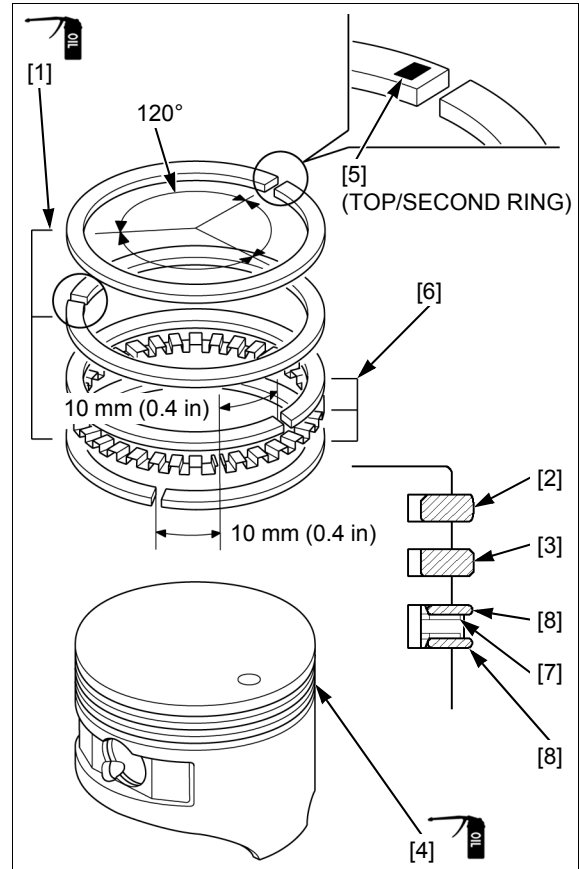

Apply engine oil to the piston [1] outer surface.

Apply engine oil to the connecting rod upper [2] small end inner surface and big end inner surface.

Apply engine oil to the piston pin [3] whole surface.

Set the connecting rod upper with the long end toward the index mark [4] on the piston head.

Install the piston and insert the piston pin through the piston and connecting rod.

Install two new piston pin clips [5] into the grooves in the piston pin hole.

### NOTE:

- Make sure the piston pin clips are seated securely.
- Do not align the piston pin clip end gap with the piston cut-out.

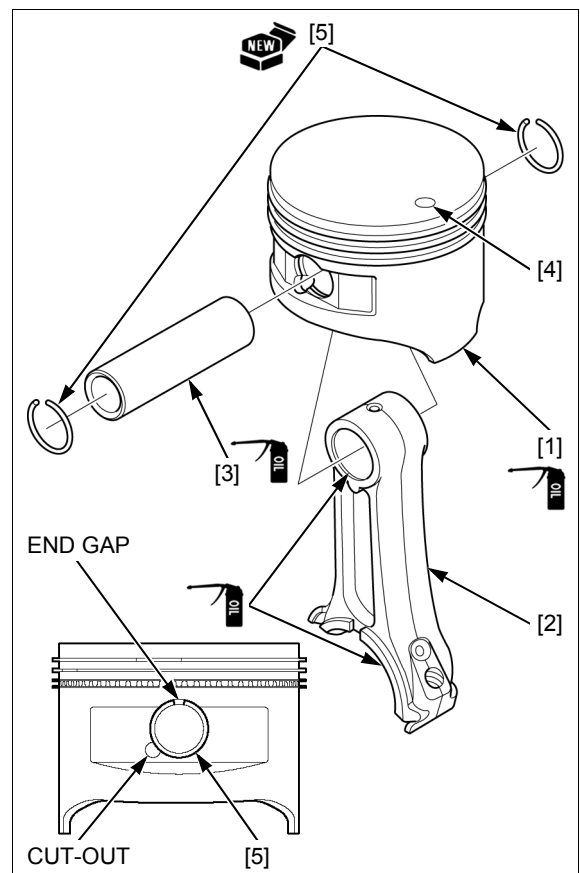

# CRANKCASE COVER/CYLINDER BLOCK/PISTON/CONNECTING ROD/CRANKSHAFT/CAMSHAFT INSPECTION

## CAMSHAFT HOLDER I.D.

Measure the camshaft holder I.D.

**STANDARD:**

14.000 – 14.018 mm (0.5512 – 0.5519 in)

**SERVICE LIMIT:**

14.048 mm (0.5531 in)

If the measurement is more than the service limit, replace the crankcase cover and cylinder block (page 13-3).

Inspect the camshaft O.D. (page 13-11) with this inspection.

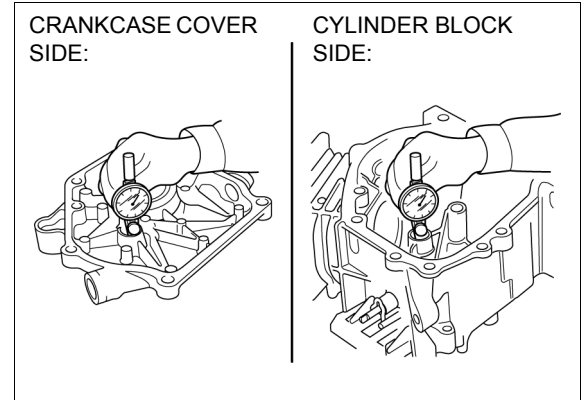

## CYLINDER SLEEVE I.D.

Measure and record the cylinder I.D. at three levels in both the "X" axis (perpendicular to crankshaft) and the "Y" axis (parallel to crankshaft). Take the maximum reading to determine cylinder wear and taper.

**STANDARD:**

68.000 – 68.015 mm (2.6772 – 2.6778 in)

**SERVICE LIMIT:**

68.165 mm (2.6837 in)

If the measurement is more than the service limit, replace the cylinder block (page 13-3).

Inspect the piston skirt O.D. (page 13-7) with this inspection.

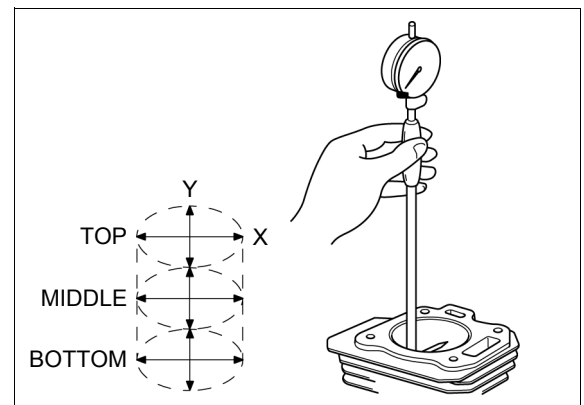

## PISTON SKIRT O.D.

Measure and record the piston O.D. at a point 10 mm (0.4 in) from the bottom of the skirt and 90° to the piston pin bore.

**STANDARD:**

67.965 – 67.985 mm (2.6758 – 2.6766 in)

**SERVICE LIMIT:**

67.845 mm (2.6711 in)

If the measurement is less than the service limit, replace the piston (page 13-5).

Inspect the cylinder sleeve I.D. (page 13-7) with this inspection.

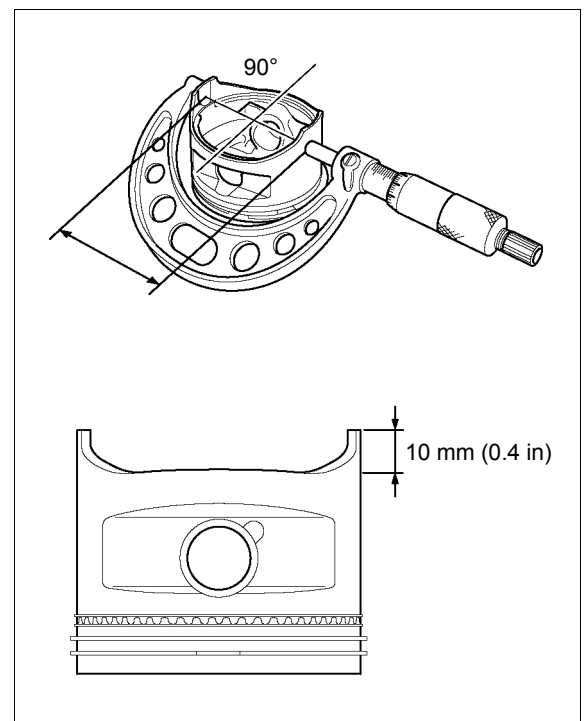

## CYLINDER BLOCK

### PISTON-TO-CYLINDER CLEARANCE

Subtract the piston skirt O.D. from the cylinder sleeve I.D. to obtain the piston-to-cylinder clearance.

**STANDARD:**

**0.015 – 0.050 mm (0.0006 – 0.0020 in)**

**SERVICE LIMIT:**

**0.12 mm (0.005 in)**

If the calculated clearance is more than the service limit, replace the piston (page 13-5) and recheck the clearance.

If the clearance is still more than the service limit with the new piston, replace the cylinder block (page 13-3).

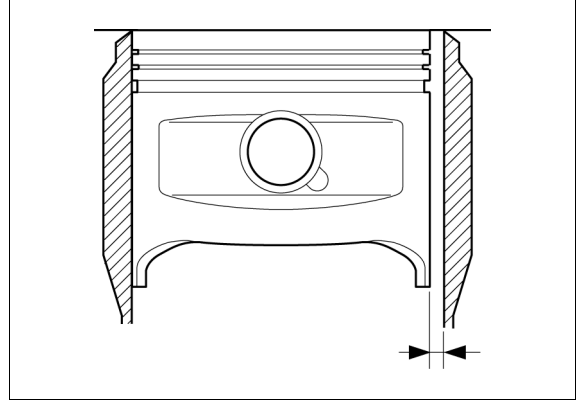

### PISTON PIN BORE I.D.

Measure and record the piston pin bore I.D. of the piston.

**STANDARD:**

**18.002 – 18.008 mm (0.7087 – 0.7090 in)**

**SERVICE LIMIT:**

**18.048 mm (0.7106 in)**

If the measurement is less than the service limit, replace the piston (page 13-5).

Inspect the piston pin O.D. (page 13-8) with this inspection.

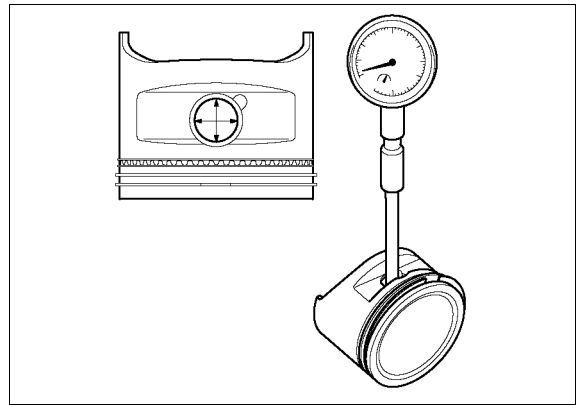

### PISTON PIN O.D.

Measure and record the piston pin O.D. at three points (both ends and middle). Take the minimum reading to determine piston pin O.D.

**STANDARD:**

**17.994 – 18.000 mm (0.7084 – 0.7087 in)**

**SERVICE LIMIT:**

**17.954 mm (0.7068 in)**

If the measurement is less than the service limit, replace the piston pin.

Inspect the piston pin bore I.D. (page 13-8).

Inspect the connecting rod small end I.D. (page 13-10) with this inspection.

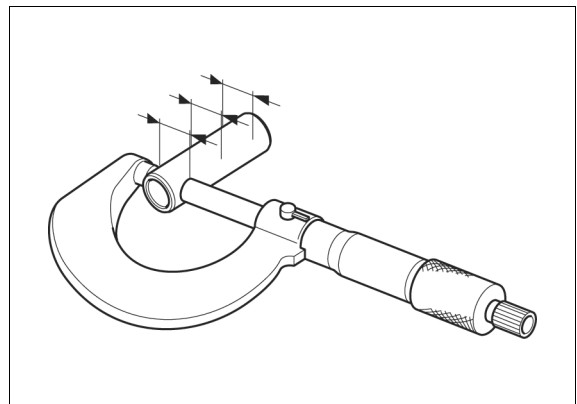

### PISTON PIN-TO-PISTON PIN BORE CLEARANCE

Subtract the piston pin O.D. from the piston pin bore I.D. to obtain the piston pin-to-piston pin bore clearance.

**STANDARD:**

**0.002 – 0.014 mm (0.0001 – 0.0006 in)**

**SERVICE LIMIT:**

**0.06 mm (0.002 in)**

If the calculated clearance is more than the service limit, replace the piston pin (page 13-5) and recheck the clearance.

If the clearance is still more than the service limit with the new piston pin, replace the piston (page 13-5).

## PISTON RING WIDTH

Measure each piston ring width.

### STANDARD:

Top: 0.95 – 0.97 mm (0.037 – 0.038 in)

Second: 0.94 – 0.96 mm (0.037 – 0.038 in)

### SERVICE LIMIT:

Top: 0.93 mm (0.037 in)

Second: 0.92 mm (0.036 in)

If any of the measurements is less than the service limit, replace the piston rings (top, second, oil) as a set (page 13-5).

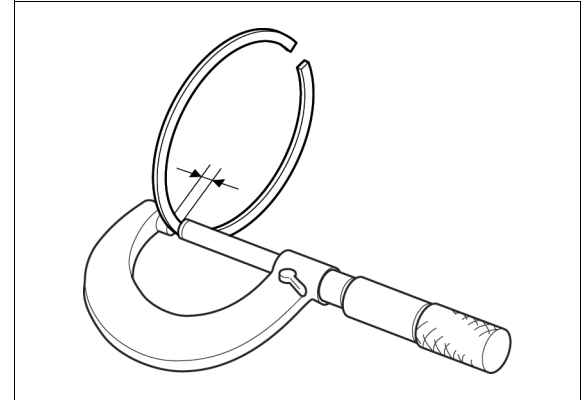

## PISTON RING SIDE CLEARANCE

Measure the clearance between each piston ring and ring groove of the piston using a thickness gauge.

### STANDARD:

Top: 0.035 – 0.070 mm (0.0014 – 0.0028 in)

Second: 0.045 – 0.080 mm (0.0018 – 0.0032 in)

### SERVICE LIMIT:

Top/second: 0.15 mm (0.006 in)

If any of the measurements is more than the service limit, inspect the piston ring width.

If the piston ring width is normal, replace the piston (page 13-5) and reinspect the clearance.

If necessary, replace the piston rings (top, second, oil) as a set (page 13-5) and reinspect the clearance.

If any of the measurements is still more than the service limit with the new piston rings, replace the piston (page 13-5).

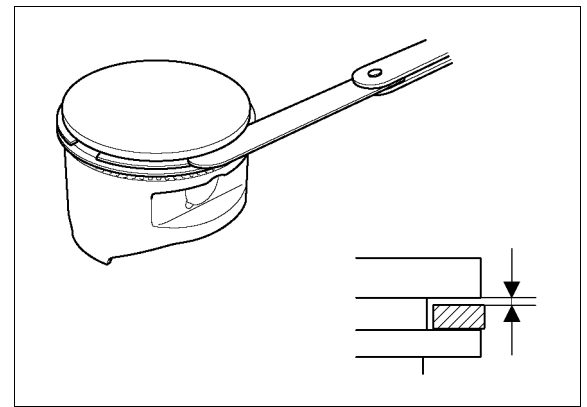

## PISTON RING END GAP

Before inspection, check whether the cylinder sleeve I.D. (page 13-7) is within the specification.

Measure each piston ring [1] end gap using a thickness gauge.

### STANDARD:

Top: 0.200 – 0.350 mm (0.0079 – 0.0138 in)

Second: 0.350 – 0.500 mm (0.0138 – 0.0197 in)

Oil (side rail) 0.20 – 0.70 mm (0.008 – 0.028 in)

### SERVICE LIMIT:

Top/second: 1.0 mm (0.04 in)

Oil (side rail) 1.0 mm (0.04 in)

If any of the measurements is more than the service limit, replace the piston rings (top, second, oil) as a set (page 13-5).

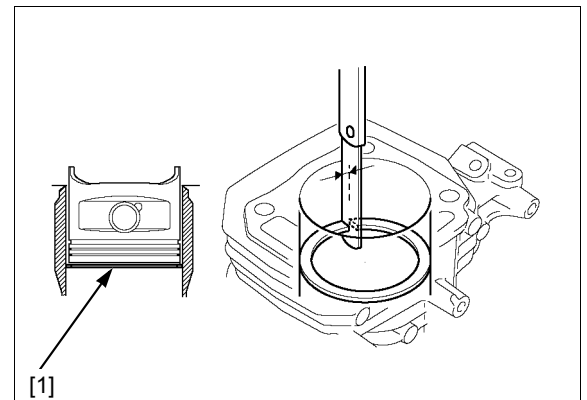

## CYLINDER BLOCK

### CONNECTING ROD SMALL END I.D.

Measure the connecting rod small end I.D.

**STANDARD:**

18.005 – 18.020 mm (0.7089 – 0.7094 in)

**SERVICE LIMIT:**

18.07 mm (0.711 in)

If the measurement is more than the service limit, replace the connecting rod upper (page 13-5).

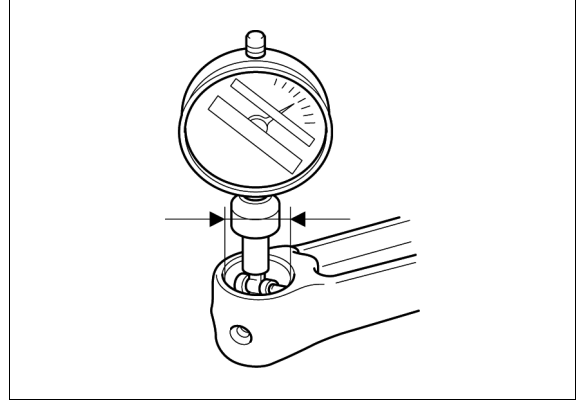

### CONNECTING ROD BIG END I.D.

Set the connecting rod cap to the connecting rod upper. Apply engine oil to the two connecting rod bolts threads and seating surface.

Tighten the connecting rod bolts to the specified torque.

**TORQUE: 12 N·m (1.2 kgf·m, 9 lbf·ft)**

Measure the connecting rod big end I.D.

**STANDARD:**

30.020 – 30.033 mm (1.1819 – 1.1824 in)

**SERVICE LIMIT:**

30.066 mm (1.1837 in)

If the measurement is more than the service limit, replace the connecting rod upper (page 13-5) and connecting rod cap (page 13-3).

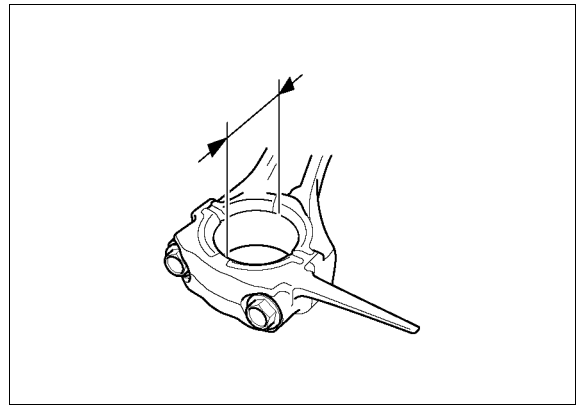

### CONNECTING ROD BIG END SIDE CLEARANCE

Measure the clearance between the connecting rod big end and crankshaft using a thickness gauge.

**STANDARD: 0.10 – 0.40 mm (0.004 – 0.016 in)**

**SERVICE LIMIT: 1.10 mm (0.043 in)**

If the measurement is more than the service limit, replace the connecting rod upper (page 13-5), connecting rod cap (page 13-3) and recheck the clearance.

If the clearance is still more than the service limit with the new connecting rod, replace the crankshaft (page 13-3).

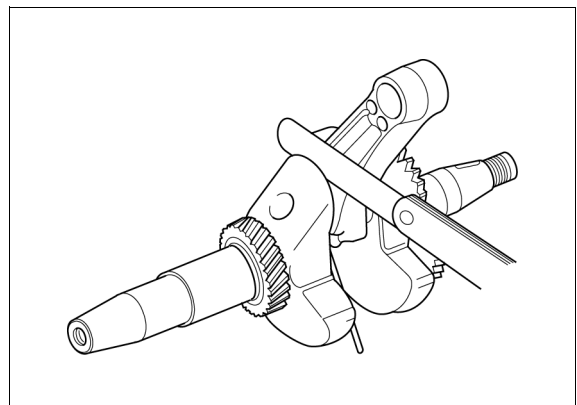

### CONNECTING ROD BIG END OIL CLEARANCE

Clean all oil from the crankpin and connecting rod big end surface.

Place a piece of plastigauge [1] on the crankpin, install the connecting rod upper and the connecting rod lower. Apply engine oil to the connecting rod bolt threads and seating surface.

Tighten the two connecting rod bolts to the specified torque.

**TORQUE: 12 N·m (1.2 kgf·m, 9 lbf·ft)**

**NOTE:**

Do not rotate the crankshaft while the plastigauge is in place.

Remove the connecting rod and measure the plastigauge [1].

**STANDARD:**

**0.040 – 0.063 mm (0.0016 – 0.0025 in)**

**SERVICE LIMIT:**

**0.12 mm (0.005 in)**

If the clearance is more than the service limit, inspect the following:

- Connecting rod big end I.D. (page 13-10)
- Crankpin O.D. (page 13-11)

If the part that is not within the service limit replaces a new one, reinspect the clearance.

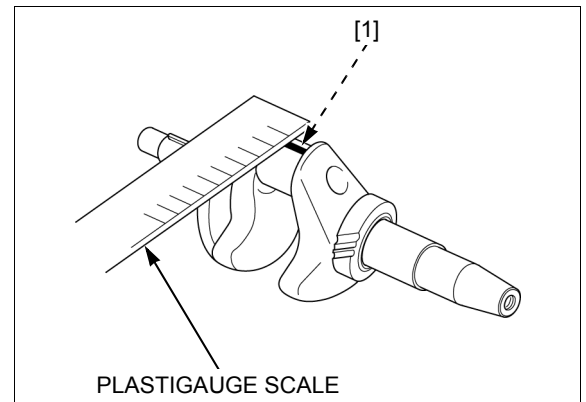
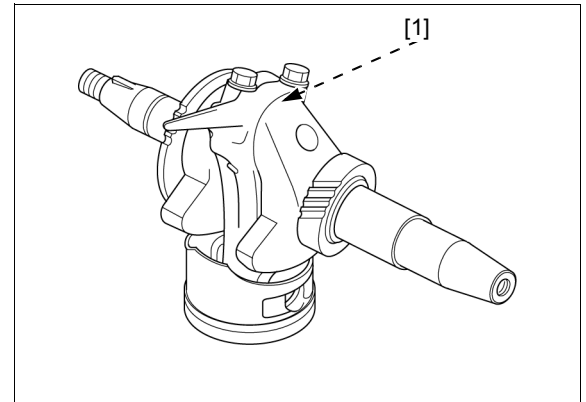

### CRANKPIN O.D.

Measure the crankpin O.D. of the crankshaft.

**STANDARD:**

**29.970 – 29.980 mm (1.1799 – 1.1803 in)**

**SERVICE LIMIT:**

**29.920 mm (1.1780 in)**

If the measurement is less than the service limit, replace the crankshaft (page 13-3).

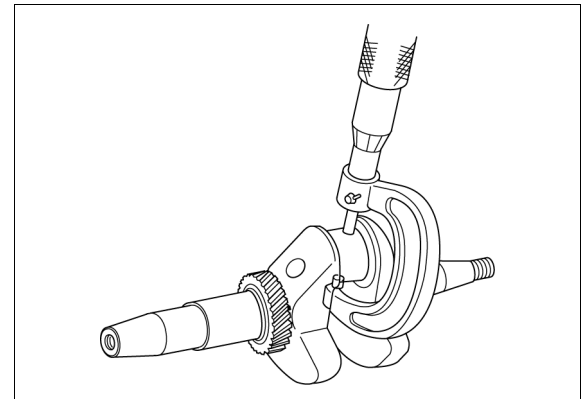

### CAMSHAFT O.D.

Measure the camshaft O.D.

**STANDARD:**

**13.966 – 13.984 mm (0.5498 – 0.5506 in)**

**SERVICE LIMIT:**

**13.916 mm (0.5479 in)**

If the measurement is less than the service limit, replace the camshaft (page 13-3).

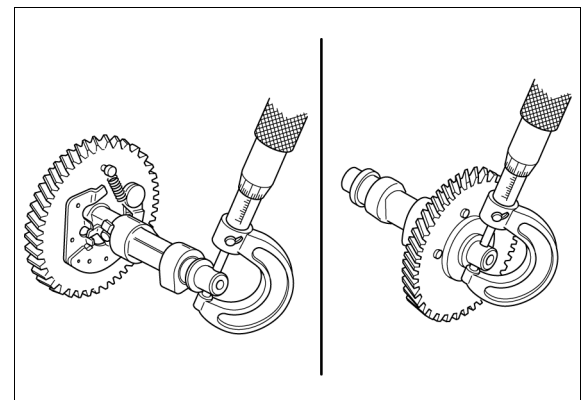

## CYLINDER BLOCK

### CAMSHAFT CAM HEIGHT

Measure the cam height of the camshaft.

**STANDARD:**

**IN:** 27.500 – 27.900 mm (1.0827 – 1.0984 in)

**EX:** 27.547 – 27.947 mm (1.0845 – 1.1003 in)

**SERVICE LIMIT:**

**IN:** 27.45 mm (1.081 in)

**EX:** 27.50 mm (1.083 in)

If the measurement is less than the service limit, replace the camshaft (page 13-3).

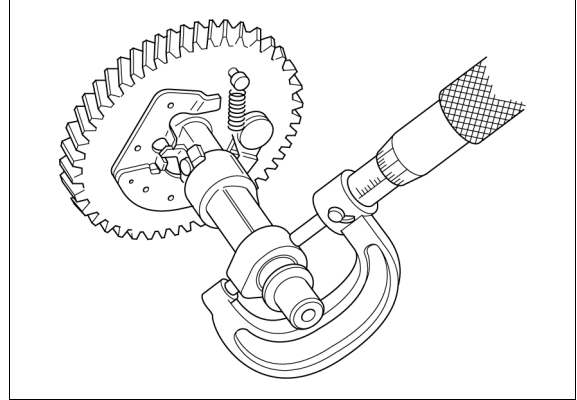

### DECOMPRESSOR WEIGHT

Check for worn and weakened spring.

If the return spring [1] is worn or weakened, replace the weight return spring.

Check that the decompressor weight moves smoothly.

If the decompressor weight does not move correctly, replace the camshaft (page 13-3).

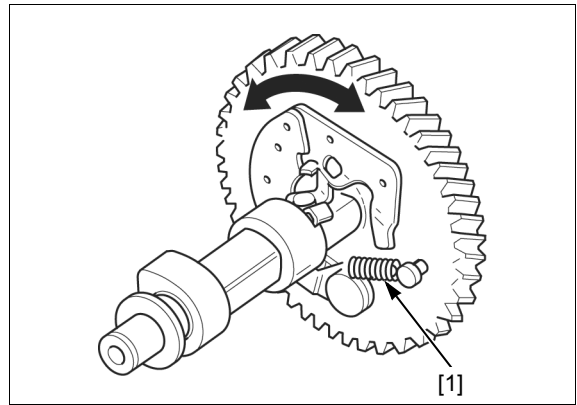

### CRANKSHAFT BEARING

Clean the bearing with solvent and dry it thoroughly.

Turn the inner race of the crankshaft bearing with your finger and check for play.

If it is noisy or has excessive play, replace the crankshaft bearing (page 13-13).

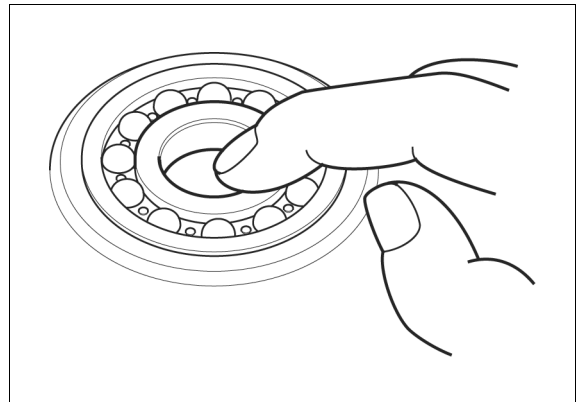

# CRANKSHAFT BEARING/OIL SEAL REPLACEMENT

## CRANKSHAFT BEARING

*Cylinder block side:* Drive out the bearing (6205) from the cylinder block (page 13-3).

*Crankcase cover side:* Drive out the bearing (6205) from the crankcase cover (page 13-3).

Drive a new bearing [1] with its marked side facing up until it is fully seated on the end using the special tools.

**TOOLS:**

**Attachment, 52 x 55 mm [2]      07746-0010400**

**Pilot, 25 mm [3]                    07746-0040600**

**Driver [4]                                07749-0010000**

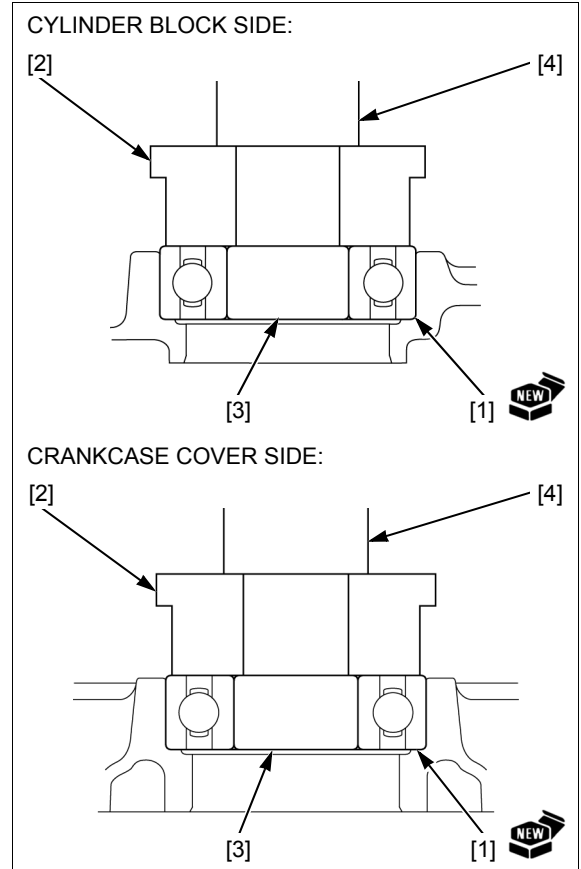

## CRANKSHAFT OIL SEAL

*Cylinder block side:* Remove the oil seal (25 x 41 x 6 mm) from the cylinder block (page 13-3).

*Crankcase cover side:* Remove the oil seal (25 x 41 x 6 mm) from the crankcase cover (page 13-3).

Apply grease to the lips of a new oil seal (25 x 41 x 6 mm) [1].

Drive the oil seal in the position as shown with its flat surface side facing up, using the special tools.

**TOOLS:**

**Attachment, 37 x 40 mm [2]      07746-0010200**

**Driver [3]                                07749-0010000**

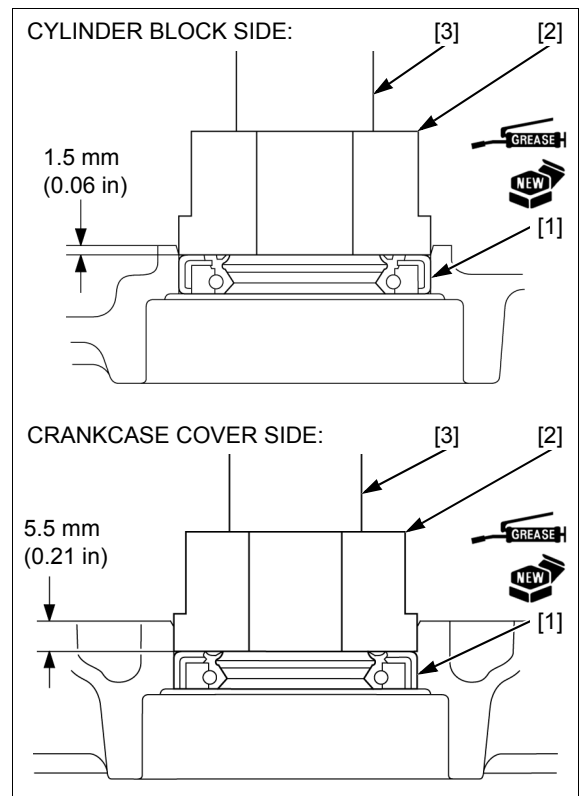

---

**MEMO**

---

HANDLE COLUMN ASSEMBLY REMOVAL/  
INSTALLATION .....14-2

HANDLE COLUMN DISASSEMBLY/  
ASSEMBLY .....14-3

CLUTCH LEVER DISASSEMBLY/  
ASSEMBLY ..... 14-4

THROTTLE LEVER DISASSEMBLY/  
ASSEMBLY ..... 14-5

# HANDLE COLUMN ASSEMBLY REMOVAL/INSTALLATION

Remove the following:

- Air cleaner (page 5-4)
- Belt cover stay (page 11-2)

Disconnect the throttle cable (page 10-2).

NOTE:

- When installing the handle column assembly, route the wire harness properly (page 2-7).

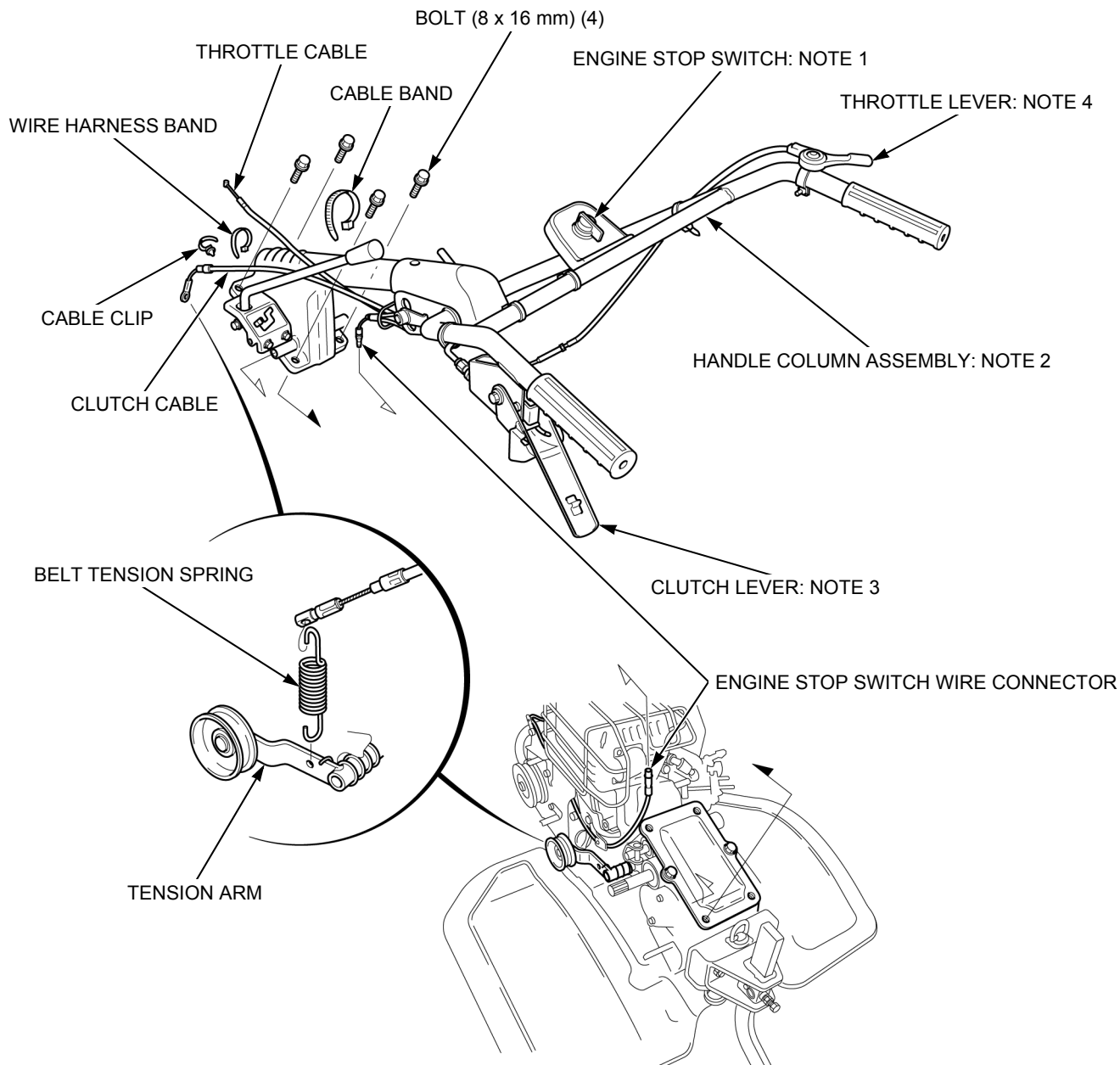

NOTE 1	ENGINE STOP SWITCH REMOVAL/INSTALLATION	page 7-7
NOTE 2	HANDLE COLUMN DISASSEMBLY/ASSEMBLY	page 14-3
NOTE 3	CLUTCH LEVER DISASSEMBLY/ASSEMBLY	page 14-4
NOTE 4	THROTTLE LEVER DISASSEMBLY/ASSEMBLY	page 14-5

# HANDLE COLUMN DISASSEMBLY/ ASSEMBLY

Remove the handle column assembly (page 14-2).

Disassemble the following:

- Engine stop switch (page 7-7)
- Clutch lever (page 14-4)
- Throttle lever (page 14-5)

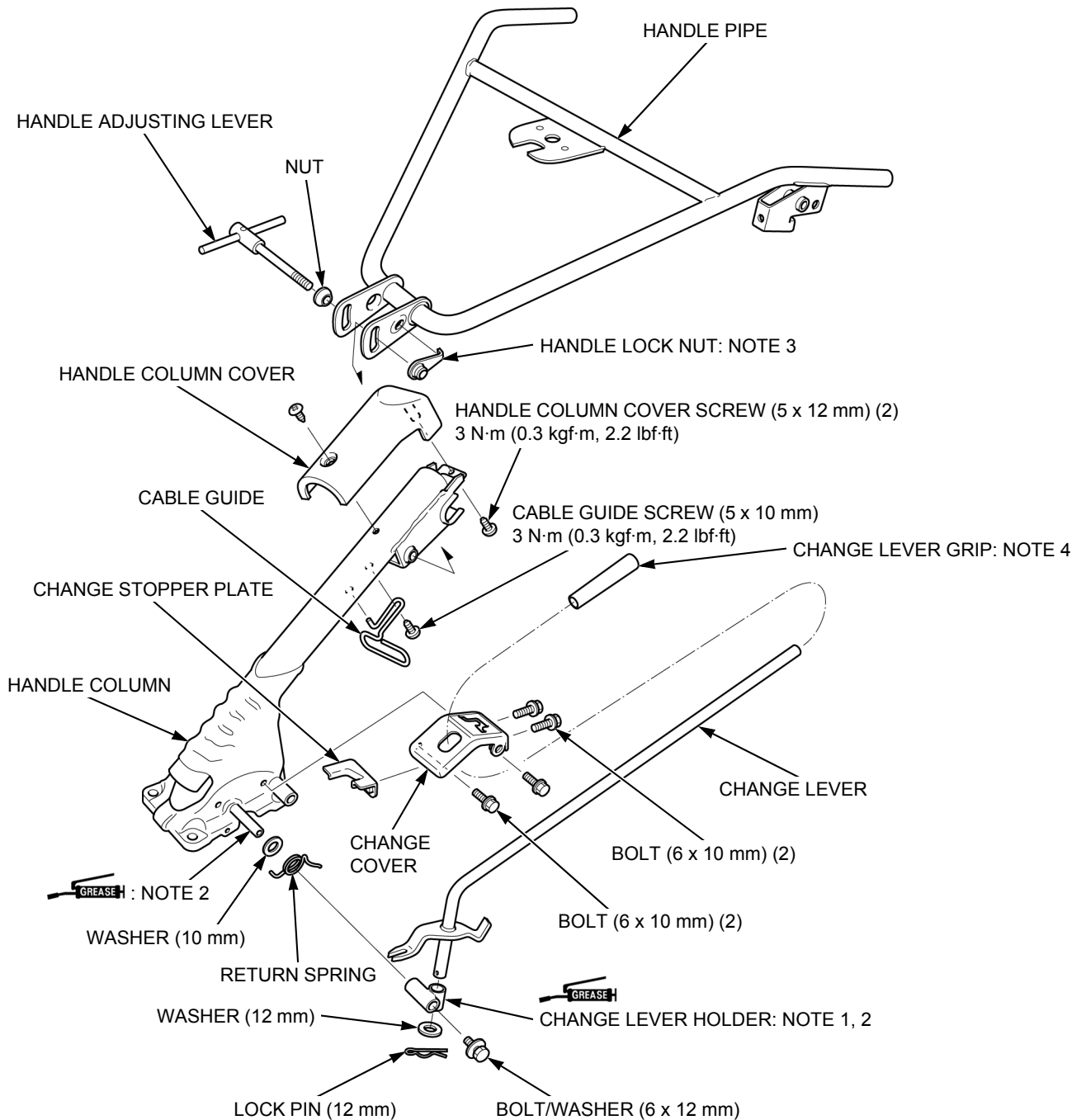

NOTE 1	When reassembly, install the long side against the handle column.	-
NOTE 2	When reassembly, apply grease to the sliding surface.	-
NOTE 3	When reassembly, install the handle lock nut tab into the handle pipe hole.	-
NOTE 4	When reassembly, apply ThreeBond® 1530C or equivalent to the inside.	-

# CLUTCH LEVER DISASSEMBLY/ ASSEMBLY

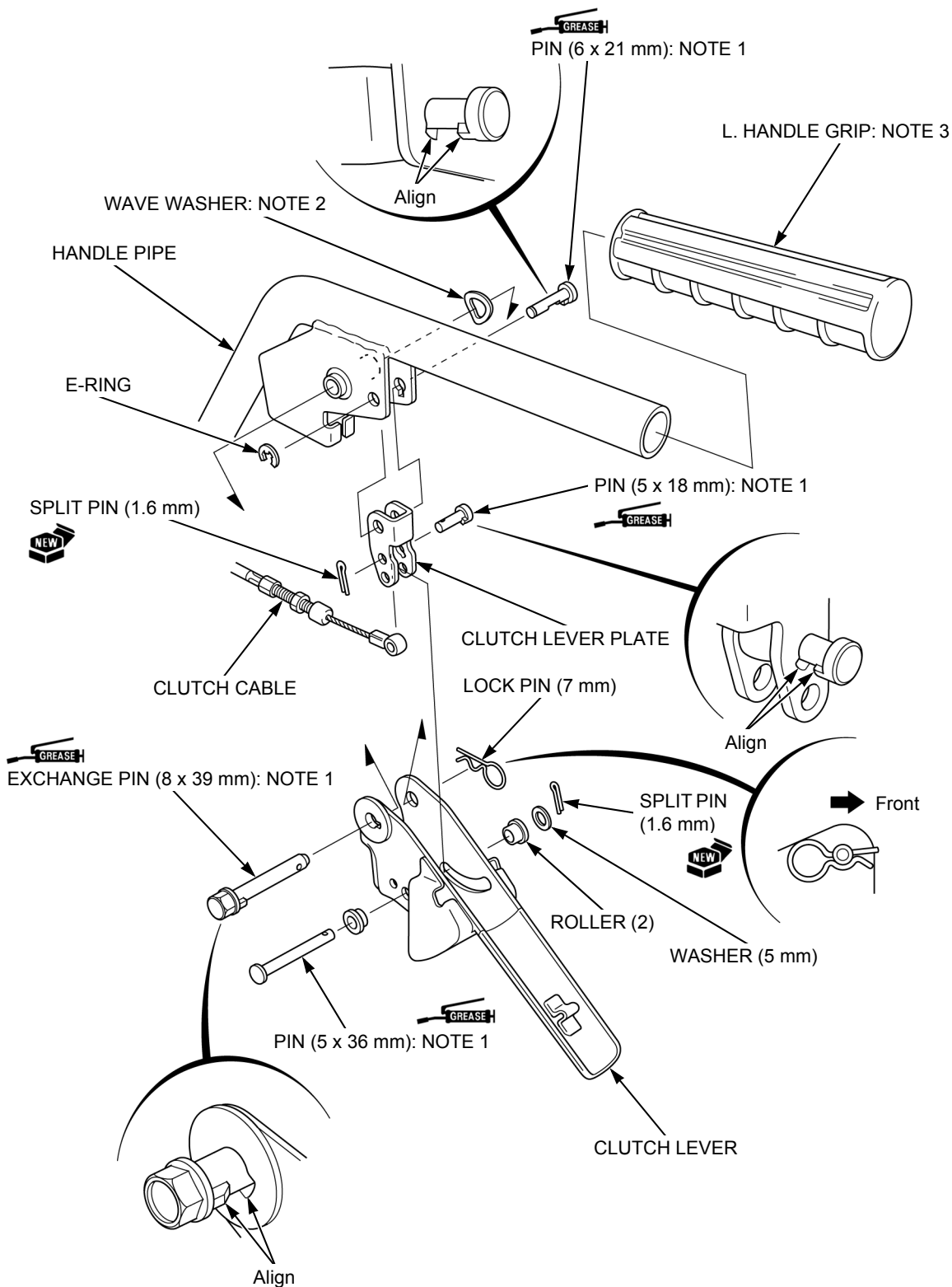

NOTE 1	When reassembly, apply grease to the sliding surface.	-
NOTE 2	When reassembly, note the installation direction.	-
NOTE 3	When reassembly, apply ThreeBond® 1530C or equivalent to the inside.	-

# THROTTLE LEVER DISASSEMBLY/ ASSEMBLY

After reassembly, perform the "THROTTLE OPERATION" (page 3-13).

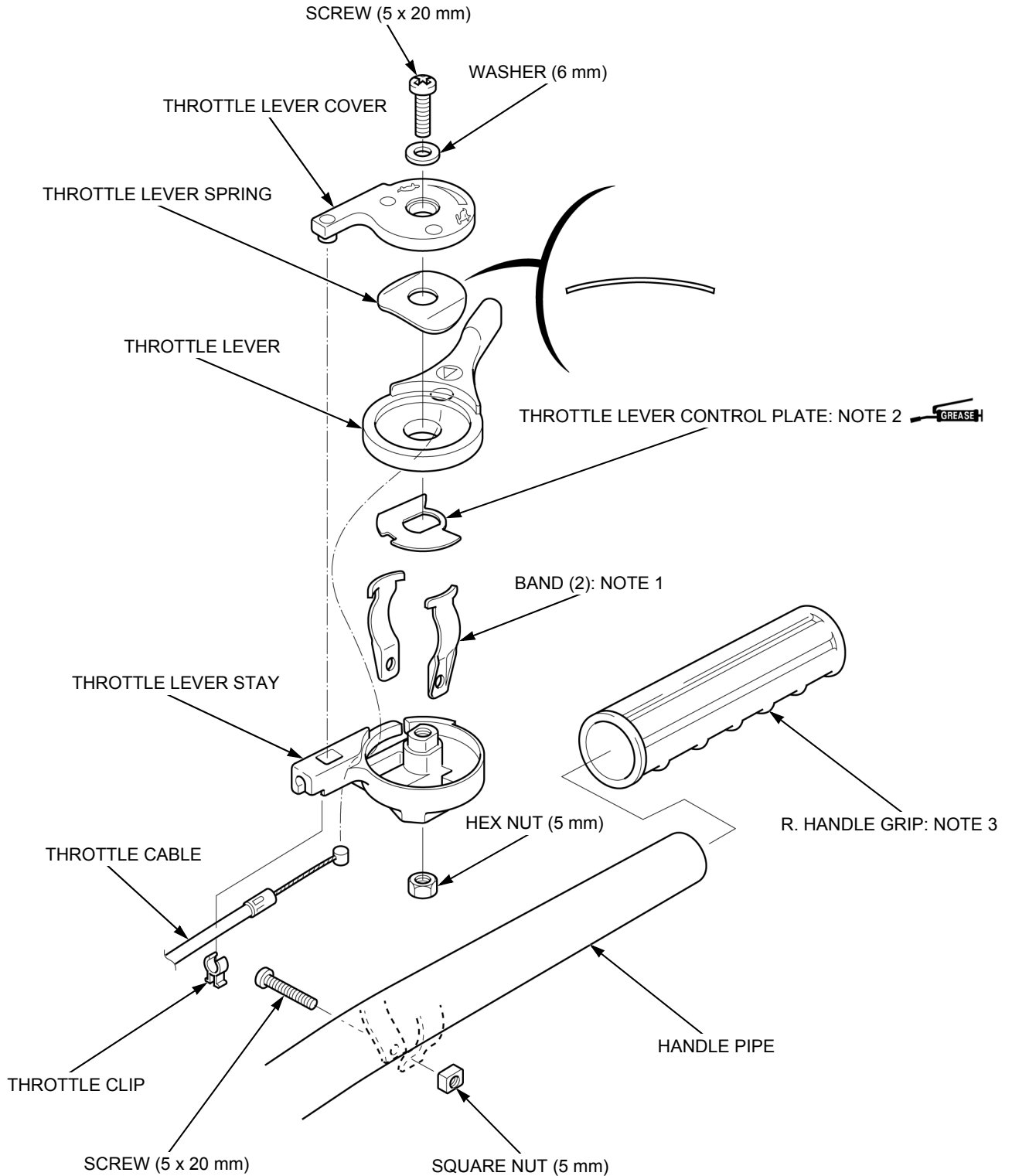

NOTE 1	When reassembly, position the bands to the specified range.	page 2-7
NOTE 2	When reassembly, apply grease to the sliding surface.	-
NOTE 3	When reassembly, apply ThreeBond® 1530C or equivalent to the inside.	-

---

**MEMO**

---

# 15. ROTOR/TRANSMISSION

---

TOOLS.....	15-2	ROTOR ASSEMBLY CHECK .....	15-6
ROTOR REMOVAL/INSTALLATION .....	15-3	TRANSMISSION REMOVAL/ INSTALLATION .....	15-7
ROTOR DISASSEMBLY/ASSEMBLY .....	15-4	TRANSMISSION DISASSEMBLY/ ASSEMBLY .....	15-8

## ROTOR/TRANSMISSION

### TOOLS

Pilot, 22 mm  
07746-0041000



Pilot, 28 mm  
07746-0041100

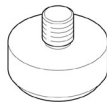

Driver  
07749-0010000

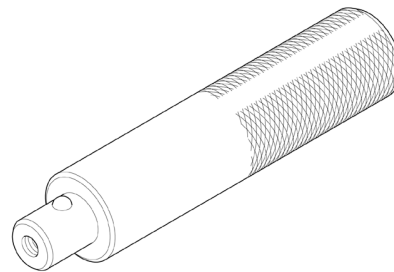

Driver, 22 mm I.D.  
07746-0020100

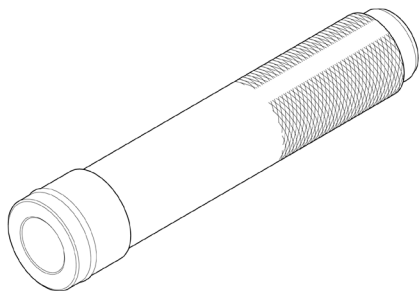

# ROTOR REMOVAL/INSTALLATION

**NOTE:**

- The right side rotors and left side rotors can be removed in the same manner.
- After installation, make sure that the right and left rotors are symmetry (page 15-6).

L. rotor shown:

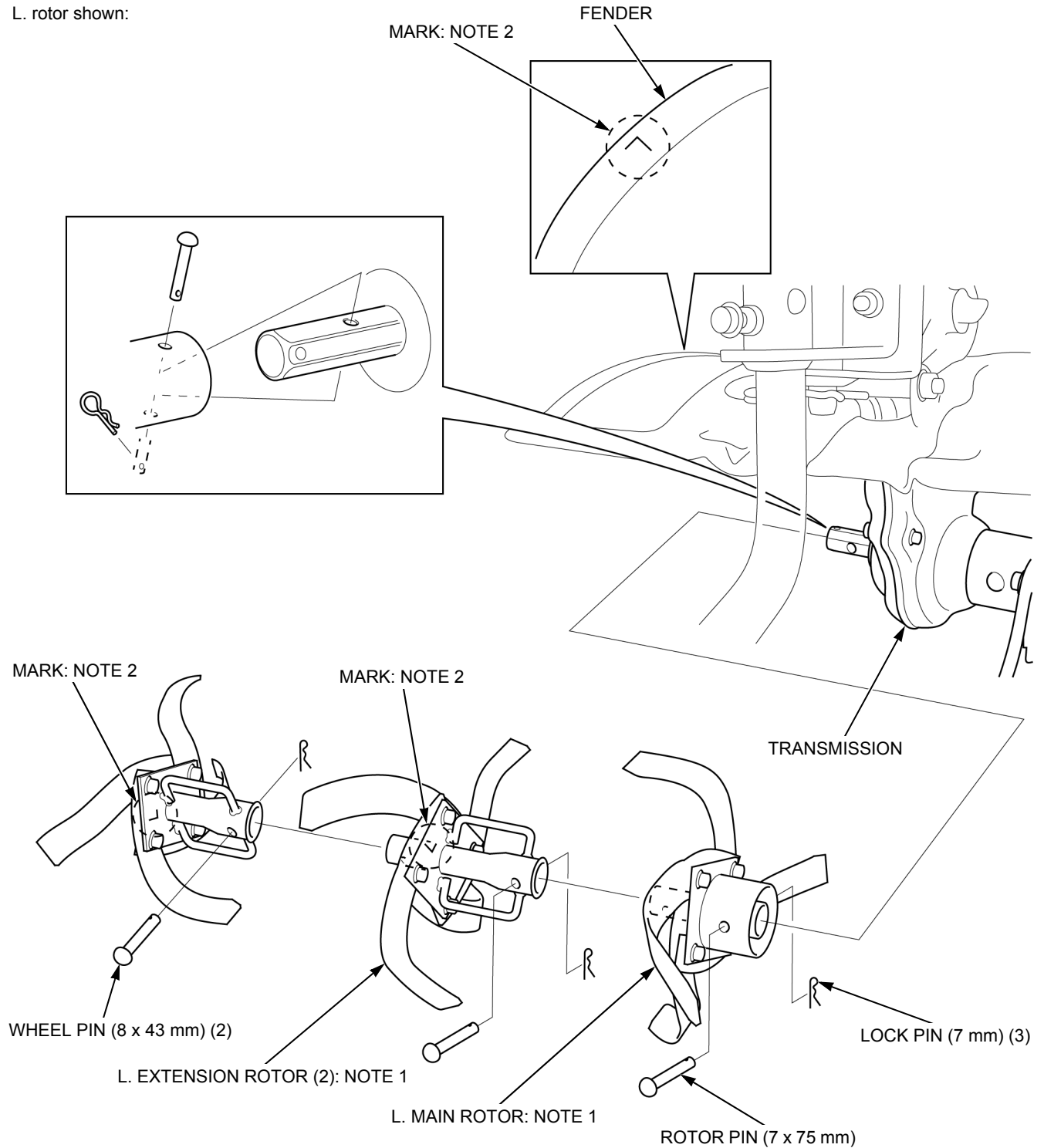

NOTE 1	ROTOR DISASSEMBLY/ASSEMBLY	page 15-4
NOTE 2	Align the mark (L or R) on the rotor with the mark (L or R) on the fender.	-

# ROTOR DISASSEMBLY/ASSEMBLY

## L. ROTOR

NOTE:

- When reassembly, assemble the tines with its identification marks ("G" and "H") facing outward.

Tine G shape:

Tine H shape:

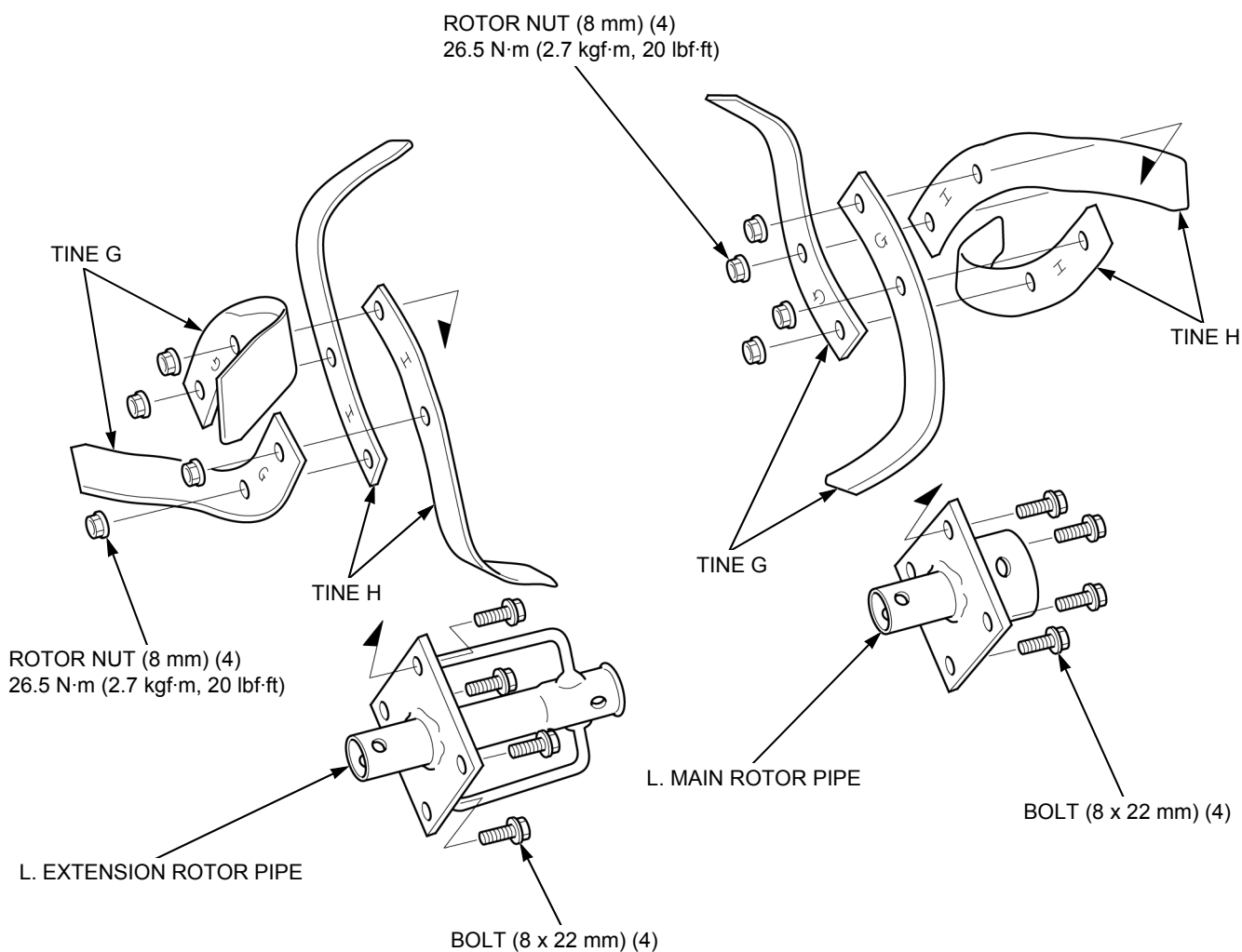
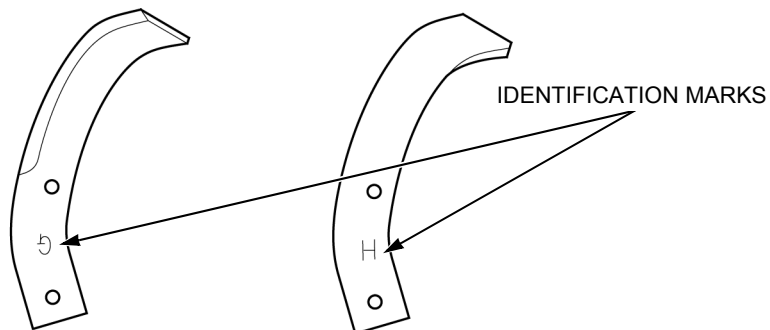

**R. ROTOR**

**NOTE:**

- When reassembly, assemble the tines with its identification marks ("G" and "H") facing inward.

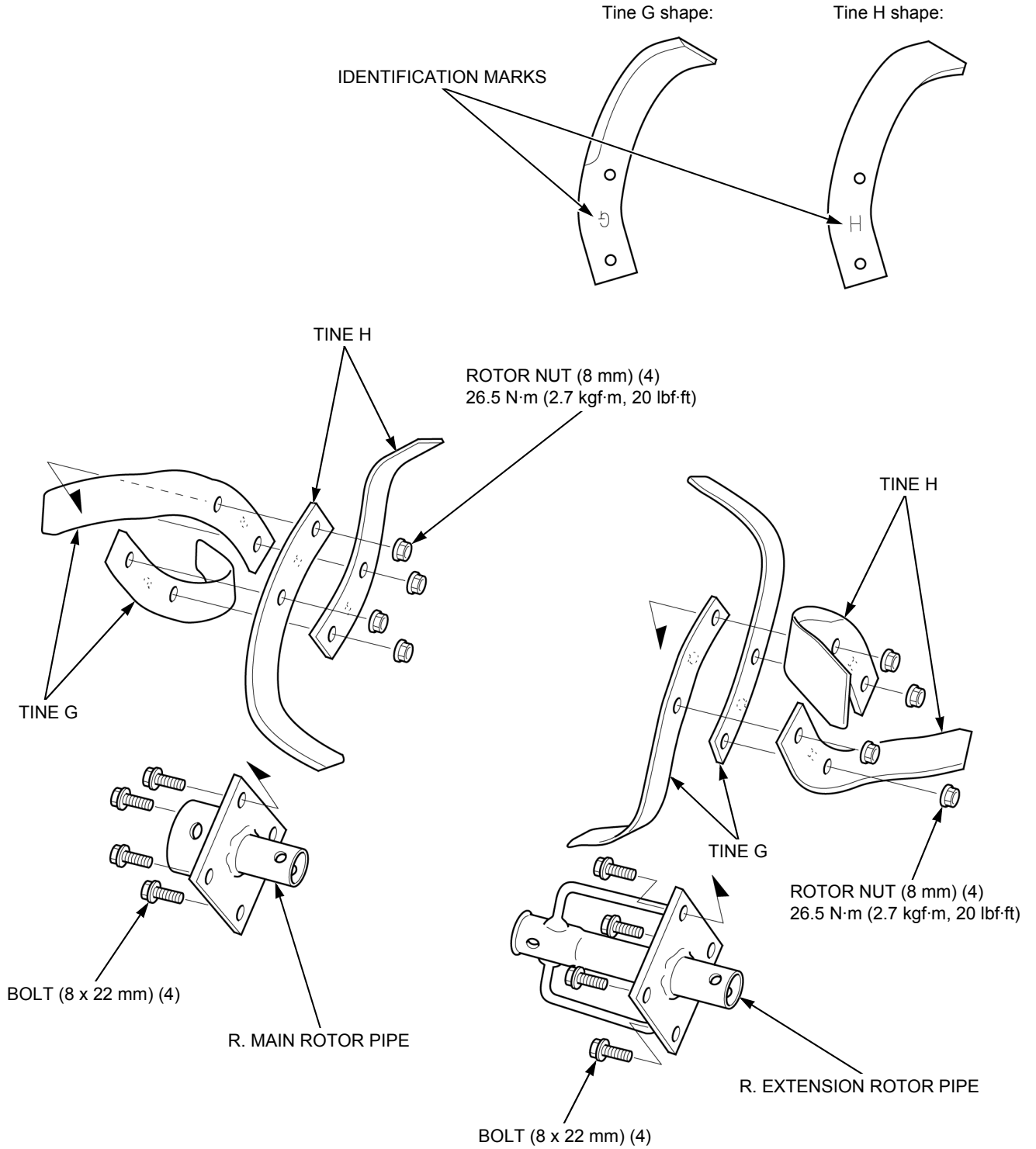

## ROTOR/TRANSMISSION

# ROTOR ASSEMBLY CHECK

Check that the tines are assembled properly as shown.

NOTE:

- The right rotors and left rotors are symmetry.

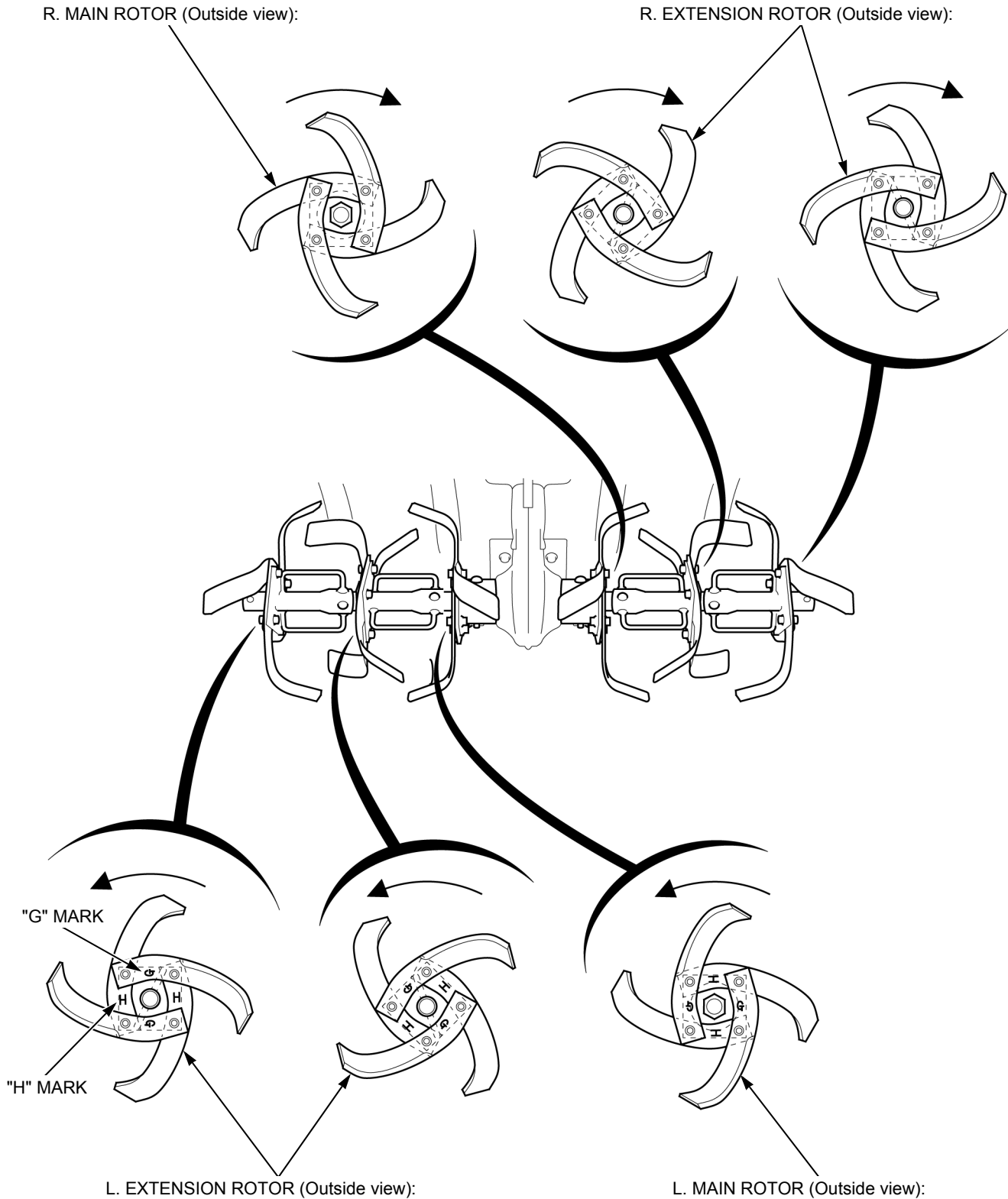

# TRANSMISSION REMOVAL/ INSTALLATION

Remove the following:

- Handle column assembly (page 14-2)
- Engine (page 10-2)
- Rotor (page 15-3)

NOTE:

- After installation, check the transmission oil level if the transmission is disassembled (page 3-9).

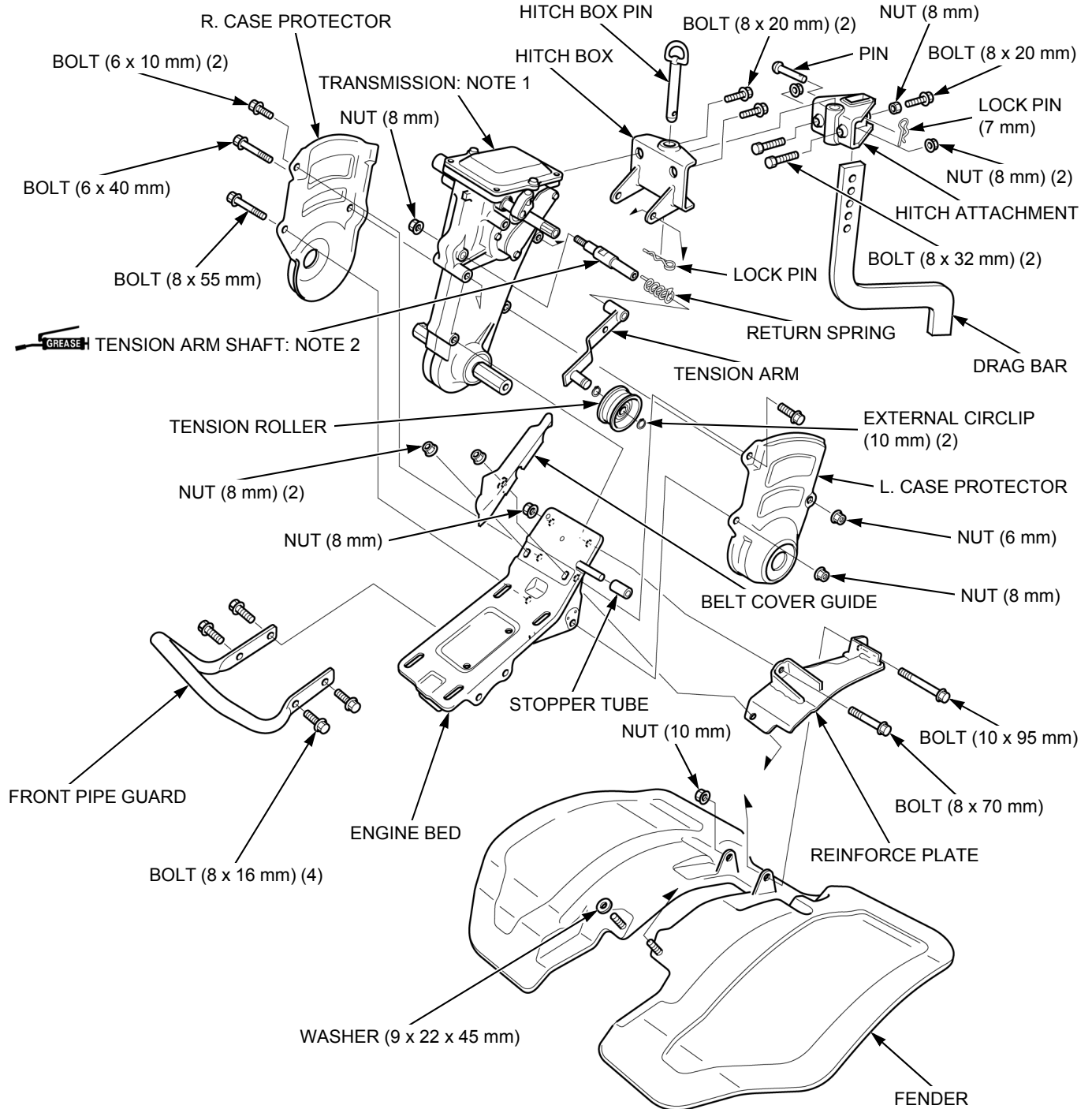

NOTE 1	TRANSMISSION DISASSEMBLY/ASSEMBLY	page 15-8
NOTE 2	When reassembly, apply grease to the sliding surface	-

# TRANSMISSION DISASSEMBLY/ ASSEMBLY

**NOTE:**

- The transmission case cannot be separated. For ease of transmission disassembly/reassembly, turn the transmission case as shown in the figure.
- When assembling the transmission, position all gears in the case and then insert the shafts.
- The gears on the final shaft and countershaft and driven sprocket can be removed without removing the input shaft.

Remove the transmission (page 15-7).

Place a suitable counter.

Remove the transmission top cover and drain the transmission oil into it.

After assembly, fill the recommended transmission oil (page 15-11).

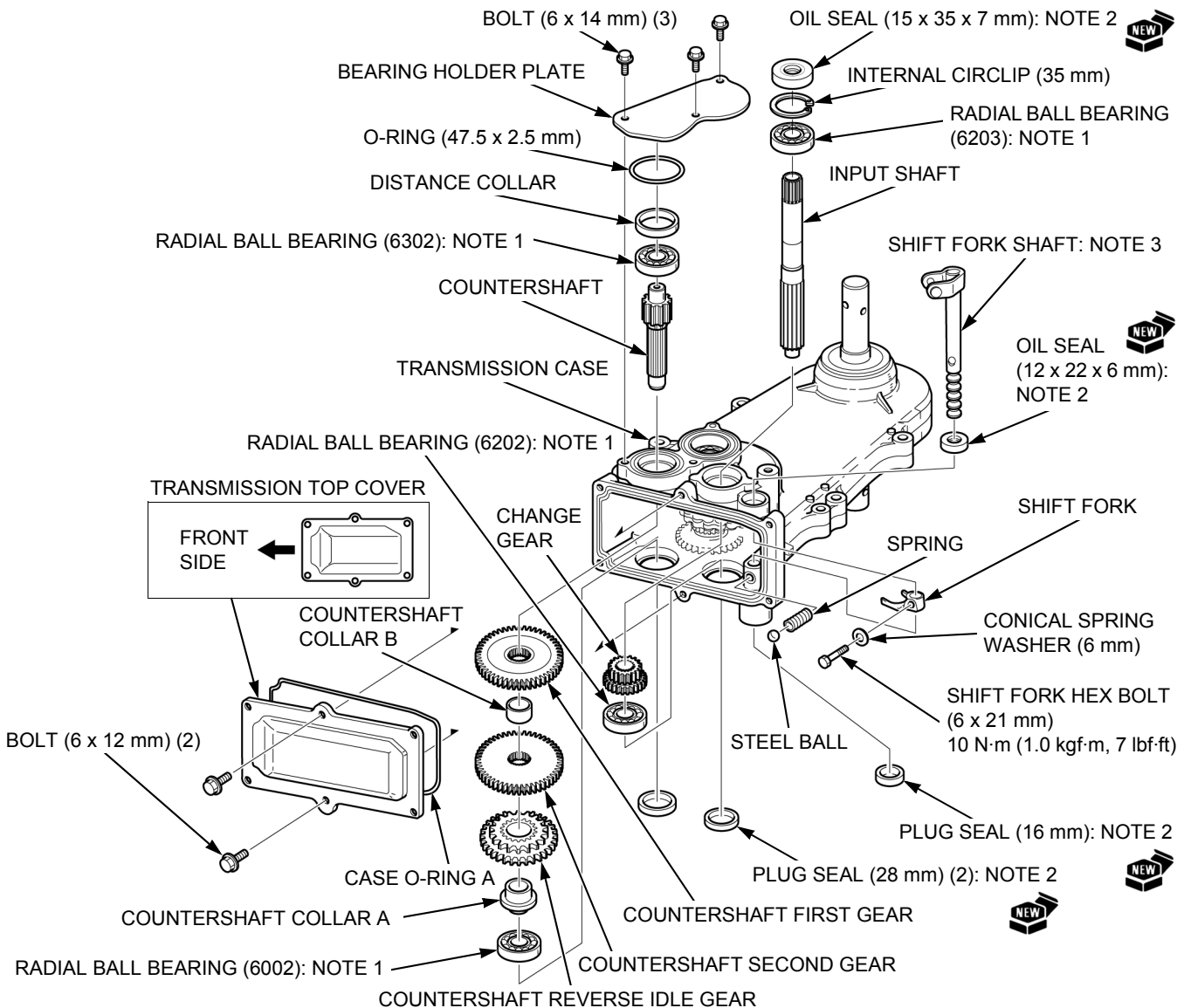

NOTE 1	RADIAL BALL BEARING INSPECTION	page 15-10
NOTE 2	PLUG SEAL/OIL SEAL/WATER SEAL INSTALLATION	page 15-10
NOTE 3	SHIFT FORK SHAFT INSTALLATION	page 15-11

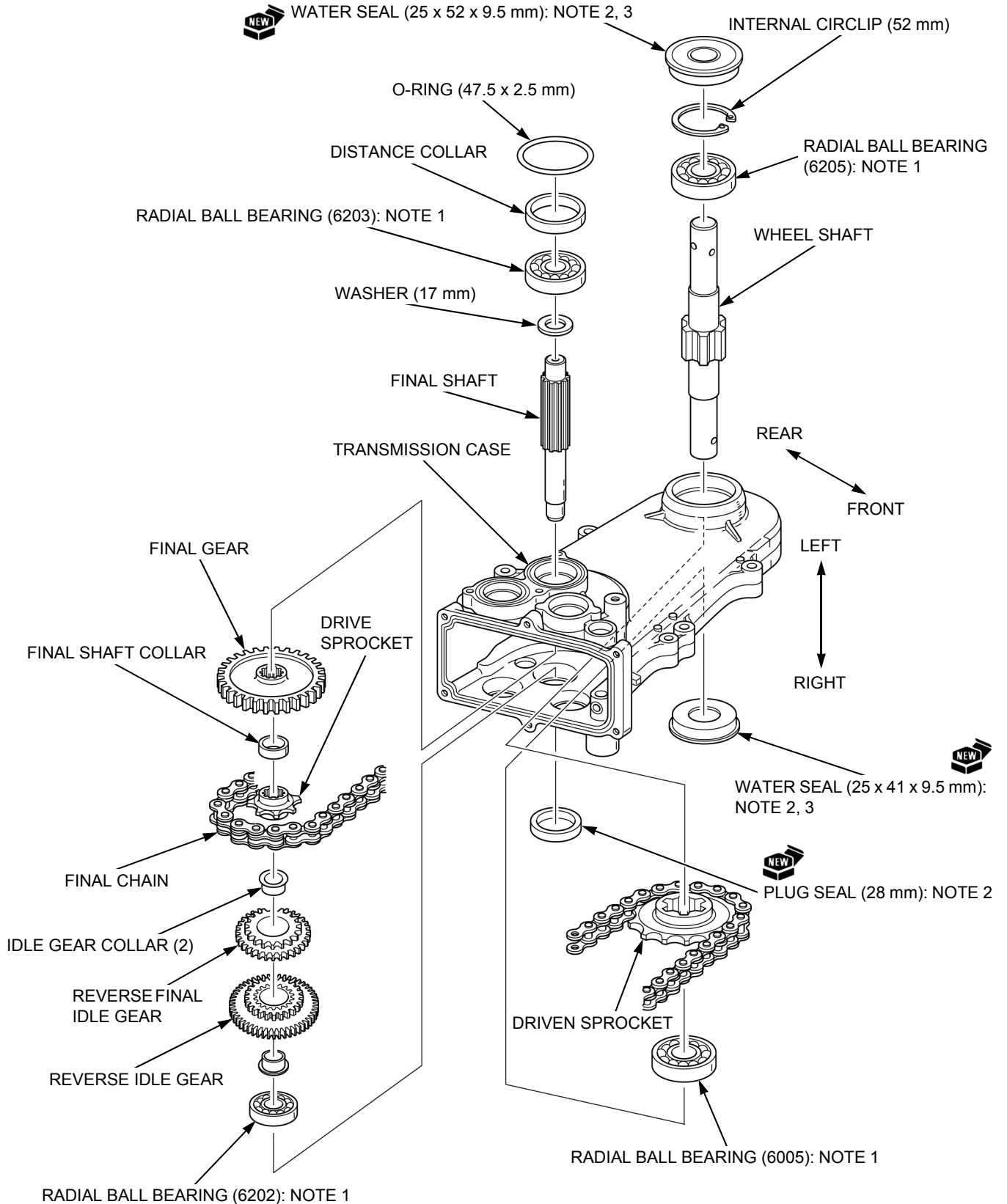

NOTE 1	RADIAL BALL BEARING INSPECTION	page 15-10
NOTE 2	PLUG SEAL/OIL SEAL/WATER SEAL INSTALLATION	page 15-10
NOTE 3	When disassembly, take care not to damage the transmission case and wheel shaft.	-

## RADIAL BALL BEARING INSPECTION

Clean the bearing with solvent and dry it thoroughly.

Turn the inner race or outer race of the radial ball bearing with your finger and check for play.

If it is noisy or has excessive play, replace the radial ball bearing (page 15-8).

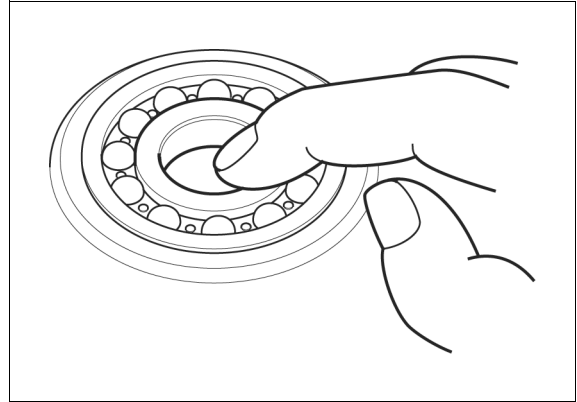

## PLUG SEAL/OIL SEAL/WATER SEAL INSTALLATION

### PLUG SEAL (28 mm)

Drive a new plug seal (28 mm) [1] from outside until it is flush with the transmission case surface by using the special tools.

#### TOOLS:

Pilot, 28 mm [2]

07746-0041100

Driver [3]

07749-0010000

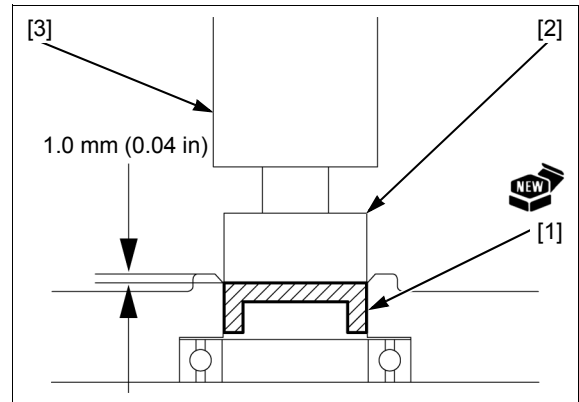

### PLUG SEAL (16 mm)/OIL SEAL (12 x 22 x 6 mm)

Drive a new plug seal (16 mm)/oil seal (12 x 22 x 6 mm) from outside until it is flush with the transmission case surface by using the special tools.

#### TOOLS:

Plug seal (16 mm) [1]:

Pilot, 22 mm [2]

07746-0041000

Driver [3]

07749-0010000

Oil seal (12 x 22 x 6 mm) [4]:

Pilot, 28 mm [5]

07746-0041100

Driver

07749-0010000

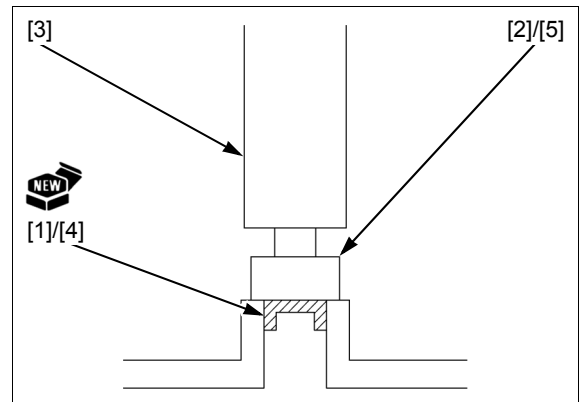

**OIL SEAL (15 x 35 x 7 mm)**

Drive a new oil seal (15 x 35 x 7 mm) [1] from outside until it is flush with the transmission case surface by using the special tools.

**TOOL:**

**Driver, 22 mm I.D. [2]**

**07746-0020100**

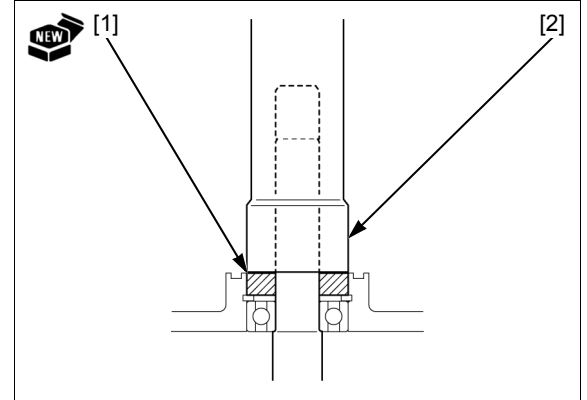

**WATER SEAL (25 x 52 x 9.5 mm)/WATER SEAL (25 x 41 x 9.5 mm)**

Install a new water seal (25 x 52 x 9.5 mm) [1]/water seal (25 x 41 x 9.5 mm) [2] until it is fully seated by using the special tool and hydraulic press.

**TOOL:**

**Driver, 22 mm I.D. [3]**

**07746-0020100**

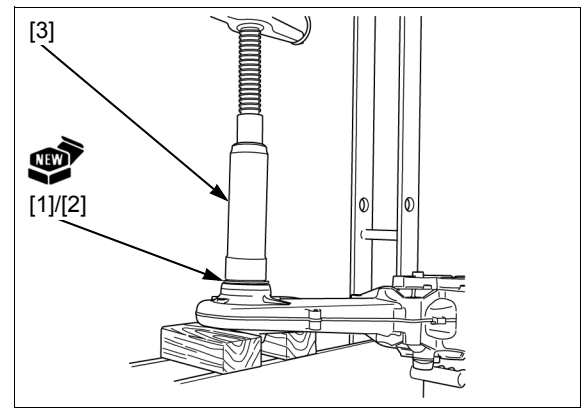

**SHIFT FORK SHAFT INSTALLATION**

Push the steel ball [1] into the transmission case [2] against the spring [3] with the suitable rod [4] and insert the shift fork shaft [5].

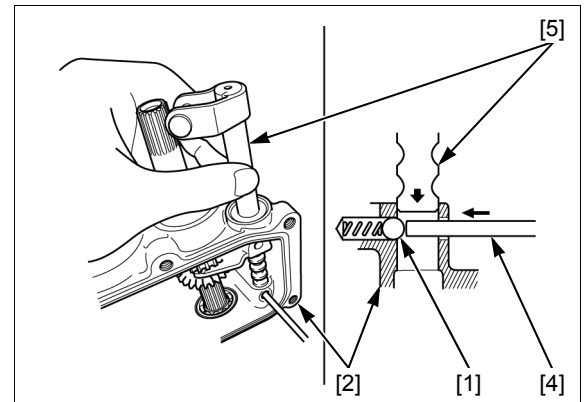

**TRANSMISSION OIL FILLING**

Fill the specified amount of recommended transmission oil into the transmission case.

**RECOMMENDED TRANSMISSION OIL:**

**SAE 10W-30**

**API service classification SE or higher**

**TRANSMISSION OIL CAPACITY:**

**0.95 liter (1.00 US qt, 0.84 Imp qt)**

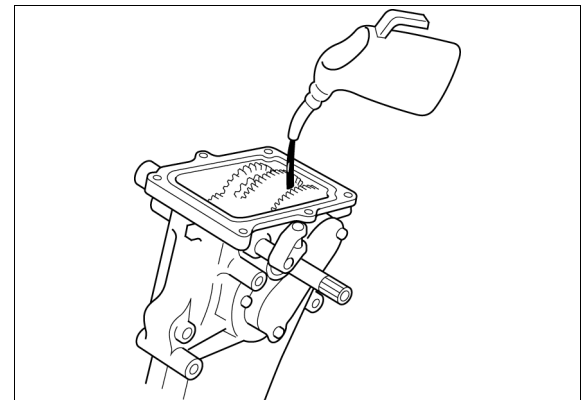

---

**MEMO**

---

ONE TOUCH DRAIN SYSTEM .....16-2

## TECHNICAL FEATURE

# ONE TOUCH DRAIN SYSTEM

## FEATURE

The function to drain the fuel from the float chamber has been combined with the fuel valve lever.

## CONSTRUCTION

One touch drain system assembly consists of the float chamber [1], valve seal [2], O-ring [3], fuel valve [4], wave washer [5], spring [6], stopper button [7], fuel valve cover [8], valve cover screws (3 x 5 mm) [9], fuel valve lever [10], fuel valve lever screw (3 x 11 mm) [11].

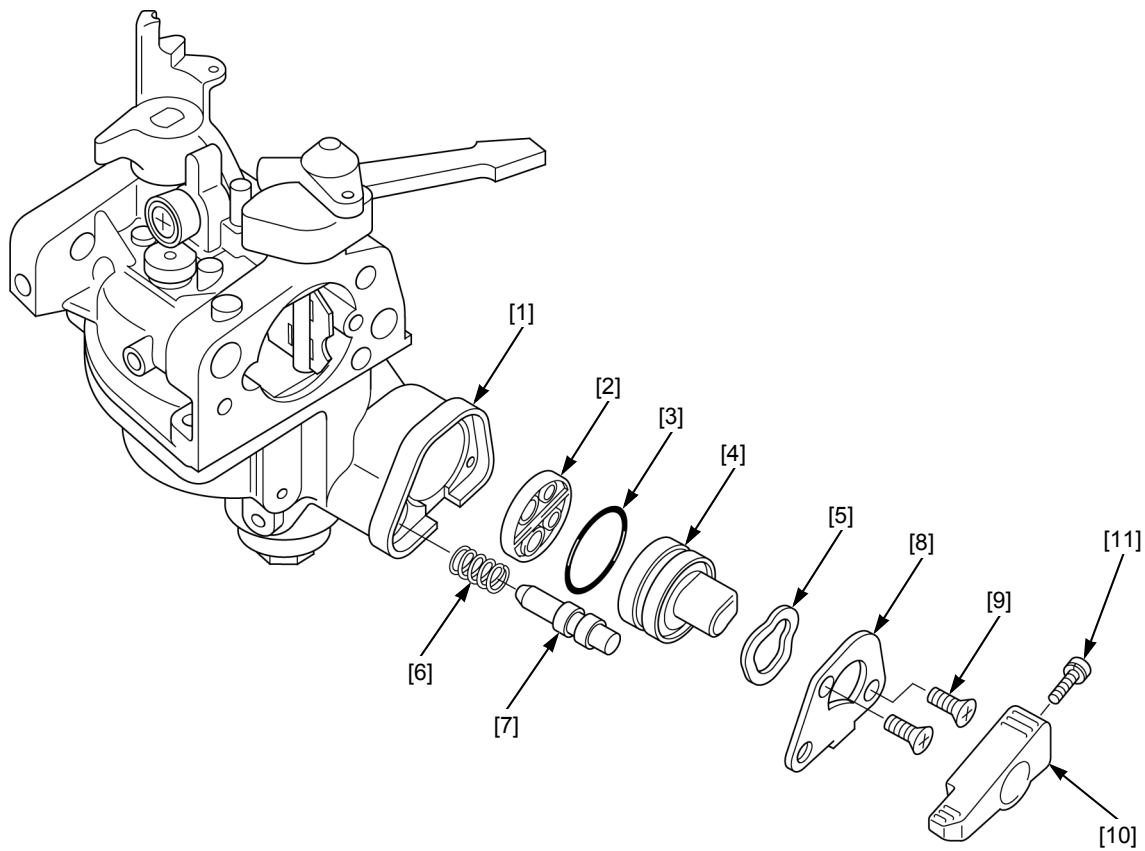

**FUNCTION**

**"ON" POSITION**

When the fuel valve lever [1] is turned to "ON" position, the fuel passed the fuel tube [2] from the fuel tank flows in the float chamber [3], through the groove [4] in the fuel valve [5].

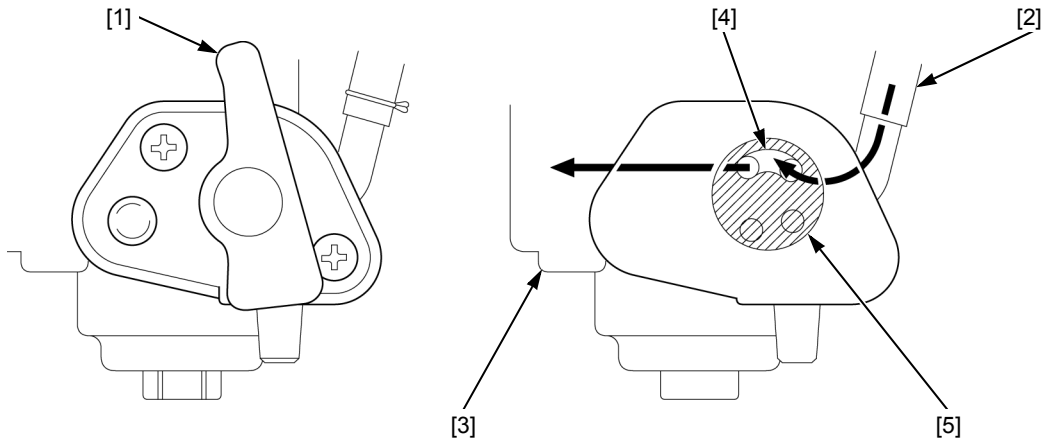

**"OFF" POSITION**

When the fuel valve lever [1] is turned to "OFF" position, the fuel passed the fuel tube [2] from the fuel tank is stopped with the fuel valve [3].

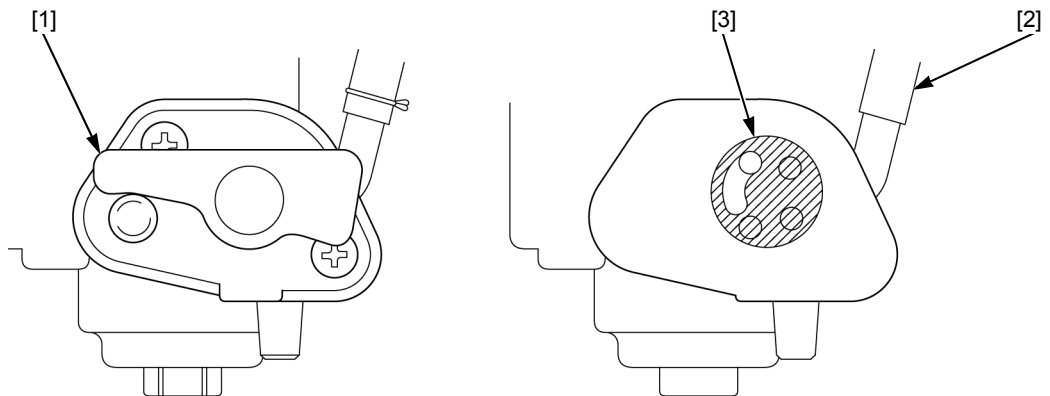

**"DRAIN" POSITION**

When the fuel valve lever [1] is turned to "DRAIN" position, the fuel in the float chamber [2] is drained from the drain joint [3] to the outside through the groove [4] in the fuel valve [5].

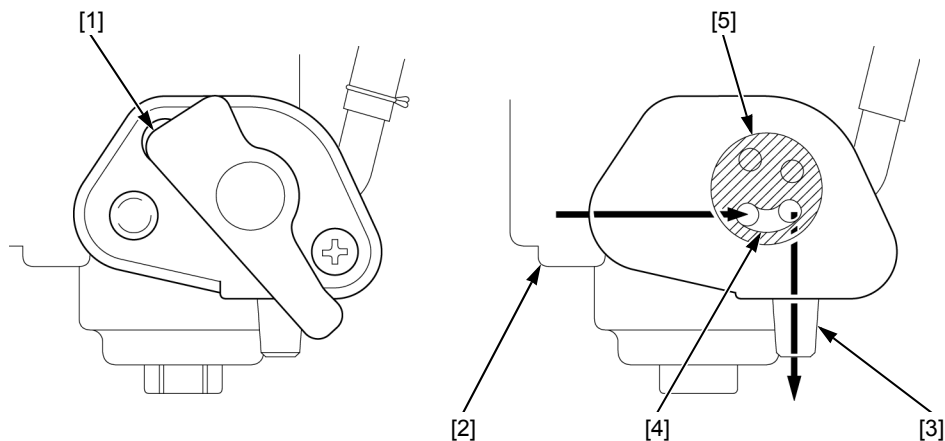

---

**MEMO**

---

# INDEX

AIR CLEANER CHECK/CLEANING/REPLACEMENT	3-5
AIR CLEANER REMOVAL/INSTALLATION	5-4
BEFORE TROUBLESHOOTING	
IGNITION SYSTEM	7-2
TROUBLESHOOTING	4-2
BELT CHECK/ADJUSTMENT	3-7
CABLE/HARNESS ROUTING	2-7
CARBURETOR DISASSEMBLY/ASSEMBLY	5-6
CARBURETOR REMOVAL/INSTALLATION	5-5
CLUTCH CABLE CHECK/ADJUSTMENT	3-6
CLUTCH LEVER DISASSEMBLY/ASSEMBLY	14-4
COMBUSTION CHAMBER CLEANING	3-14
CONTROL BASE/GOVERNOR ARM REMOVAL/ INSTALLATION	6-2
CRANKCASE COVER/CRANKSHAFT/CAMSHAFT/ PISTON REMOVAL/INSTALLATION	13-3
CRANKCASE COVER/CYLINDER BLOCK/PISTON/ CONNECTING ROD/CRANKSHAFT/CAMSHAFT INSPECTION	13-7
CRANKSHAFT BEARING/OIL SEAL REPLACEMENT	13-13
CYLINDER HEAD DISASSEMBLY/ASSEMBLY	12-4
CYLINDER HEAD REMOVAL/INSTALLATION	12-3
CYLINDER HEAD/VALVES INSPECTION	12-5
DIMENSIONAL DRAWINGS	1-5
ENGINE IDLE SPEED CHECK/ADJUSTMENT	3-11
ENGINE OIL CHANGE	3-4
ENGINE OIL LEVEL CHECK	3-3
ENGINE REMOVAL/INSTALLATION	10-2
ENGINE STOP SWITCH REMOVAL/INSTALLATION	7-7
ENGINE TROUBLESHOOTING	4-3
FLYWHEEL/IGNITION COIL REMOVAL/ INSTALLATION	7-3
FRAME TROUBLESHOOTING	4-3
FUEL TANK AND FILTER CLEANING	3-15
FUEL TANK REMOVAL/INSTALLATION	5-3
FUEL TUBE INSPECTION	3-15
GENERAL SYMPTOMS AND POSSIBLE CAUSES	4-2
GOVERNOR ADJUSTMENT	6-3
GOVERNOR REMOVAL/INSTALLATION	6-4
HANDLE COLUMN ASSEMBLY REMOVAL/ INSTALLATION	14-2
HANDLE COLUMN DISASSEMBLY/ASSEMBLY	14-3
IGNITION SYSTEM TROUBLESHOOTING	7-2
LUBRICATION	3-11
LUBRICATION & SEAL POINT	2-4
MAINTENANCE SCHEDULE	3-2
MAINTENANCE STANDARDS	2-2
MUFFLER REMOVAL/INSTALLATION	9-2
NUTS, BOLTS, FASTENERS	3-6
ONE TOUCH DRAIN SYSTEM	16-2
PISTON DISASSEMBLY/ASSEMBLY	13-5
PULLEY/V-BELT REMOVAL/INSTALLATION	11-2
RECOIL STARTER DISASSEMBLY/ASSEMBLY	8-3
RECOIL STARTER INSPECTION	8-2
RECOIL STARTER REMOVAL/INSTALLATION	8-2
ROTOR ASSEMBLY CHECK	15-6
ROTOR DISASSEMBLY/ASSEMBLY	15-4
ROTOR REMOVAL/INSTALLATION	15-3
SEDIMENT CUP CLEANING	3-10
SERIAL NUMBER LOCATION	1-2
SPARK PLUG INSPECTION/ADJUSTMENT/ REPLACEMENT	3-12
SPARK TEST	7-6
SPECIFICATIONS	1-3
THROTTLE CABLE CHECK/ADJUSTMENT	3-13
THROTTLE LEVER DISASSEMBLY/ASSEMBLY	14-5
TOOL	5-2
TOOLS	
CYLINDER BLOCK	13-2
CYLINDER HEAD	12-2
ROTOR/TRANSMISSION	15-2
SERVICE INFORMATION	2-5
TORQUE VALUES	2-3
TRANSMISSION DISASSEMBLY/ASSEMBLY	15-8
TRANSMISSION OIL LEVEL CHECK	3-9
TRANSMISSION REMOVAL/INSTALLATION	15-7
TUBE ROUTING	2-8
VALVE CLEARANCE CHECK/ADJUSTMENT	3-13
VALVE GUIDE REAMING	12-9
VALVE GUIDE REPLACEMENT	12-8
VALVE SEAT RECONDITIONING	12-10
WIRING DIAGRAM	1-6