

How to use this manual

A Few Words About Safety

Service Information

The service and repair information contained in this manual is intended for use by qualified, professional technicians. Attempting service or repairs without the proper training, tools, and equipment could cause injury to you and/or others. It could also damage this Honda product or create an unsafe condition.

This manual describes the proper methods and procedures for performing service, maintenance, and repairs. Some procedures require the use of special tools. Any person who intends to use a replacement part, service procedure, or a tool that is not recommended by Honda must determine the risks to their personal safety and the safe operation of this product.

If you need to replace any parts, use Honda Genuine parts with the correct part number or an equivalent part. We strongly recommend that you do not use replacement parts of inferior quality.

For Your Customer's Safety

Proper service and maintenance are essential to the customer's safety and the reliability of this product. Any error or oversight while servicing this product can result in faulty operation, damage to the product, or injury to others.

⚠ WARNING

Improper service or repairs can create an unsafe condition that can cause your customer or others to be seriously hurt or killed.

Follow the procedures and precautions in this manual and other service materials carefully.

For Your Safety

Because this manual is intended for the professional service technician, we do not provide warnings about many basic shop safety practices (e.g., Hot parts-wear gloves). If you have not received shop safety training or do not feel confident about your knowledge of safe servicing practices, we recommend that you do not attempt to perform the procedures described in this manual.

Some of the most important general service safety precautions are given below. However, we cannot warn you of every conceivable hazard that can arise in performing service and repair procedures. Only you can decide whether or not you should perform a given task.

⚠ WARNING

Failure to properly follow instructions and precautions can cause you to be seriously hurt or killed.

Follow the procedures and precautions in this manual carefully.

Important Safety Precautions

Make sure you have a clear understanding of all basic shop safety practices and that you are wearing appropriate clothing and using safety equipment. When performing any service task, be especially careful of the following:

- Read all of the instructions before you begin, and make sure you have the tools, the replacement or repair parts, and the skills required to perform the tasks safely and completely.
- Protect your eyes by using proper safety glasses, goggles, or face shields anytime you hammer, drill, grind, or work around pressurized air, pressurized liquids, springs, or other stored-energy components. If there is any doubt, put on eye protection.
- Use other protective wear when necessary, for example gloves or safety shoes. Handling hot or sharp parts can cause severe burns or cuts. Before you grab something that looks like it can hurt you, stop and put on gloves.
- Protect yourself and others whenever you have equipment hoisted in the air. Anytime you lift this product with a hoist, make sure that the hoist hook is securely attached to the product.

Make sure the engine is off before you begin any servicing procedures, unless the instruction tells you to do otherwise. This will help eliminate several potential hazards:

- Carbon monoxide poisoning from engine exhaust. Be sure there is adequate ventilation whenever you run the engine.
- Burns from hot parts. Let the engine and exhaust system cool before working in those areas.
- Injury from moving parts. If the instruction tells you to run the engine, be sure your hands, fingers, and clothing are out of the way.

Gasoline vapors and hydrogen gases from batteries are explosive. To reduce the possibility of a fire or explosion, be careful when working around gasoline or batteries.

- Use only a nonflammable solvent, not gasoline, to clean parts.
- Never store gasoline in an open container.
- Keep all cigarettes, sparks, and flames away from the battery and all fuel-related parts.

CONTENTS

SPECIFICATIONS	1
SERVICE INFORMATION	2
MAINTENANCE	3
TROUBLESHOOTING	4
FUEL SYSTEM	5
GOVERNOR SYSTEM	6
IGNITION SYSTEM	7
STARTING SYSTEM	8
MUFFLER	9
ENGINE REMOVAL/INSTALLATION	10
CLUTCH	11
CYLINDER HEAD	12
CYLINDER BLOCK	13
HANDLE	14
ROTOR/TRANSMISSION	15
WHEEL/FRONT WEIGHT	16
INDEX	

How to use this manual

INTRODUCTION

This manual covers the service and repair procedures for the Honda F300 tiller.

All information contained in this manual is based on the latest product information available at the time of printing. We reserve the right to make changes at anytime without notice.

No part of this publication may be reproduced, stored in a retrieval system, or transmitted, in any form, by any means, electronic, mechanical, photocopying, recording, or otherwise, without prior written permission of the publisher. This includes text, figures, and tables.

As you read this manual, you will find information that is preceded by a **NOTICE** symbol. The purpose of this message is to help prevent damage to this Honda product, other property, or the environment.

SAFETY MESSAGES

Your safety and the safety of others are very important. To help you make informed decisions, we have provided safety messages and other safety information throughout this manual. Of course, it is not practical or possible to warn you about all the hazards associated with servicing these products. You must use your own good judgement.

You will find important safety information in a variety of forms, including:

- Safety Labels – on the product.
- Safety Messages – preceded by a safety alert symbol  and one of three signal words, DANGER, WARNING, or CAUTION. These signal words mean:

 DANGER You WILL be KILLED or SERIOUSLY HURT if you don't follow instructions.

 WARNING You CAN be KILLED or SERIOUSLY HURT if you don't follow instructions.

 CAUTION You CAN be HURT if you don't follow instructions.

- Instructions – how to service these products correctly and safely.

© Honda Motor Co., Ltd.
SERVICE PUBLICATION OFFICE

Date of Issue: April 2016

How to use this manual









SERVICE RULES

- Use Honda Genuine or Honda-recommended parts and lubricants or their equivalents. Parts that do not meet Honda's design specifications may damage the unit.
- Use the special tools designed for the product.
- Install new gaskets, O-rings, etc. when reassembling.
- When torquing bolts or nuts, begin with larger-diameter or inner bolts first and tighten to the specified torque diagonally, unless a particular sequence is specified.
- Clean parts in cleaning solvent upon disassembly. Lubricate any sliding surfaces before reassembly.
- After reassembly, check all parts for proper installation and operation.
- Many screws used in this machine are self-tapping. Be aware that cross-threading or overtightening these screws will strip the threads and ruin the hole.

Use only metric tools when servicing this unit. Metric bolts, nuts, and screws are not interchangeable with non-metric fasteners. The use of incorrect tools and fasteners will damage the unit.

SYMBOLS

The symbols used throughout this manual show specific service procedures. If supplementary information is required pertaining to these symbols, it will be explained specifically in the text without the use of the symbols.

	Replace the part(s) with new one(s) before assembly.
	Use the recommend engine oil, unless otherwise specified.
	Use molybdenum oil solution (mixture of the engine oil and molybdenum grease in a ratio of 1:1).
	Use multi-purpose grease (lithium based multi-purpose grease NLGI #2 or equivalent).
	Use marine grease (water resistant urea based grease).
	Apply a locking agent. Use a medium strength locking agent unless otherwise specified.
	Apply sealant.
	Use automatic transmission fluid.
(O x O) (O)	Indicates the diameter, length, and quantity of metric bolts used.
page 1-1	Indicates the reference page.

How to use this manual

ABBREVIATIONS

Throughout this manual, the following abbreviations are used to identify the respective parts or systems.

Abbreviated term	Full term
ACG	Alternator
A/F	Air Fuel Ratio
API	American Petroleum Institute
Approx.	Approximately
Assy.	Assembly
ATDC	After Top Dead Center
ATF	Automatic Transmission Fluid
ATT	Attachment
BAT	Battery
BDC	Bottom Dead Center
BTDC	Before Top Dead Center
BARO	Barometric Pressure
CKP	Crankshaft Position
Comp.	Complete
CMP	Camshaft Position
CYL	Cylinder
DLC	Data Link Connector
EBT	Engine Block Temperature
ECT	Engine Coolant Temperature
ECM	Engine Control Module
EMT	Exhaust Manifold Temperature
EOP	Engine Oil Pressure
EX	Exhaust
F	Front or Forward
GND	Ground
HO ₂ S	Heated Oxygen sensor
HST	Hydrostatic Transmission
IAB	Intake Air Bypass
IAC	Idle Air Control
IAT	Intake Air Temperature
I.D.	Inside diameter
IG or IGN	Ignition
IN	Intake
INJ	Injection
L.	Left
MAP	Manifold Absolute Pressure
MIL	Malfunction Indicator Lamp
O.D.	Outside Diameter
OP	Optional Part
PGM-FI	Programmed-Fuel Injection
P/N	Part Number
Qty	Quantity
R.	Right
SAE	Society of Automotive Engineers
SCS	Service Check Signal
STD	Standard
SW	Switch
TDC	Top Dead Center
TP	Throttle Position
VST	Variable Speed Transmission
VTEC	Variable Valve Timing & Valve Lift Electronic Control

Bl	Black	G	Green	Br	Brown	Lg	Light green
Y	Yellow	R	Red	O	Orange	P	Pink
Bu	Blue	W	White	Lb	Light blue	Gr	Gray

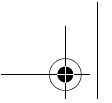

1. SPECIFICATIONS

SERIAL NUMBER LOCATION	1-2	DIMENSIONAL DRAWINGS.....	1-5
SPECIFICATIONS	1-3	WIRING DIAGRAM	1-7

SPECIFICATIONS

SERIAL NUMBER LOCATION

The engine serial number [1] is located on the cylinder block.
The frame serial number [2] is located on the handle column.
Refer to these numbers when ordering parts and when making technical inquiries.

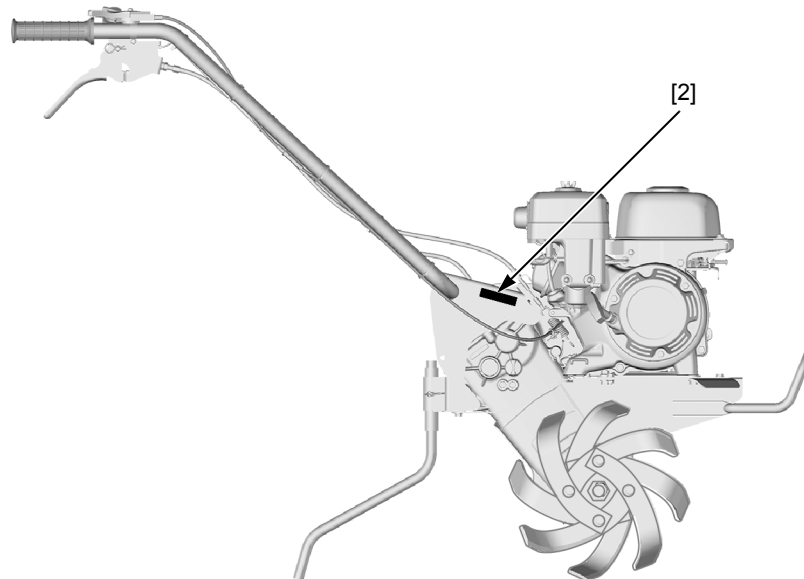
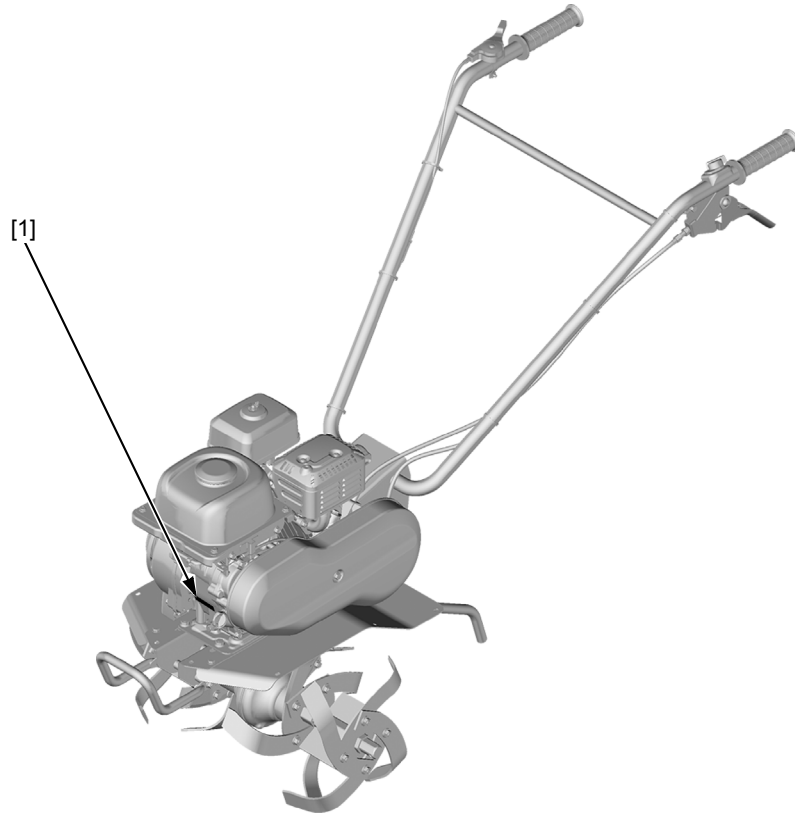

SPECIFICATIONS

SPECIFICATIONS

DIMENSIONS AND WEIGHTS

Model	F300		
Description code	FAAD		
Type code	IN	T	KW
Overall length*	1,320 mm (51.97 in)		
Overall width	550 mm (21.65 in)		
Tillage width	450 mm (17.72 in)	550 mm (21.65 in)	
Overall height*	945 mm (37.20 in)		
Minimum ground clearance	85 mm (3.35 in)		
Dry weight**	38 kg (84 lbs)		
Operating weight***	40 kg (88 lbs)		

The dimensions above are determined when tines of each rotor are put on a level surface and an engine bed is parallel to the surface.

Each mass value when french rotor is installed is given.

*: The overall length and height above are determined when the tightening position of a handle pipe is set in the middle of a vertical movable range.

** : Without oil and fuel.

***: With oil (specified upper level) and fuel (fuel tank upper level).

ENGINE

Model	GX80D
Description code	GCADD
Type	4-stroke, OHV, single cylinder, inclined by 25°
Total displacement	79.7 cm ³ (4.86 cu-in)
Bore and stroke	46.0 x 48.0 mm (1.81 x 1.89 in)
Max. horsepower	1.5 kW (2.0 PS)/3,600 min ⁻¹ (rpm)
Max. torque	4.5 N·m (0.46 kgf·m, 3.3 lbf·ft)/2,500 min ⁻¹ (rpm)
Compression ratio	9.0 : 1
Cooling system	Forced-air
Ignition system	Transistorized magneto ignition
Ignition timing	20° ± 2° B.T.D.C.
Spark plug	C4HSB (NGK)
Carburetor	Horizontal type, butterfly valve
Air cleaner	Dual element type
Lubricating system	Splash
Engine oil capacity	0.36 liter (0.38 US qt, 0.32 Imp qt)
Recommended engine oil	SAE 10W-30 API service classification SE or higher
Starting system	Recoil
Stopping system	Ignition primary circuit ground
Fuel used	Unleaded gasoline with a pump octane rating 86 or higher
Fuel tank capacity	1.4 liter (1.5 US qt, 1.2 Imp qt)

SPECIFICATIONS

FRAME

Model	F300		
Type code	IN	T	KW
Rotor type	French rotor		
Standard handle height (with rotor operation position)	905 mm (35.63 in)		
Handle height adjustment	780 – 1,020 mm (30.71 – 40.16 in)		
Tillage depth adjustment	Move drag bar up and down (3 height positions)		
Tillage width	2 strand	305 mm (12.01 in)	
	4 strand	450 mm (17.72 in)	550 mm (21.65 in)
Number of tines	2 strand	4 tines per rotor	
	4 strand	8 tines per rotor	
Rotor assembly	O.D. 300 mm		
Engine to transmission mechanism	V-belt		
V-belt	W400 SA-33		
Clutch	Belt tension type		
Clutch operation	Manual lever		
Transmission lubrication	Splash		
Transmission oil capacity	1.0 liter (1.1 US qt, 0.9 Imp qt)		
Recommended transmission oil	SAE 10W-30 API service classification SE or higher		
Transmission final gear ratio	40		
Rotor shaft speed *	99.0 min ⁻¹ (rpm)		

*: at engine speed 4,000 min⁻¹ (rpm)

SPECIFICATIONS

DIMENSIONAL DRAWINGS
IN TYPE

Unit: mm (in)

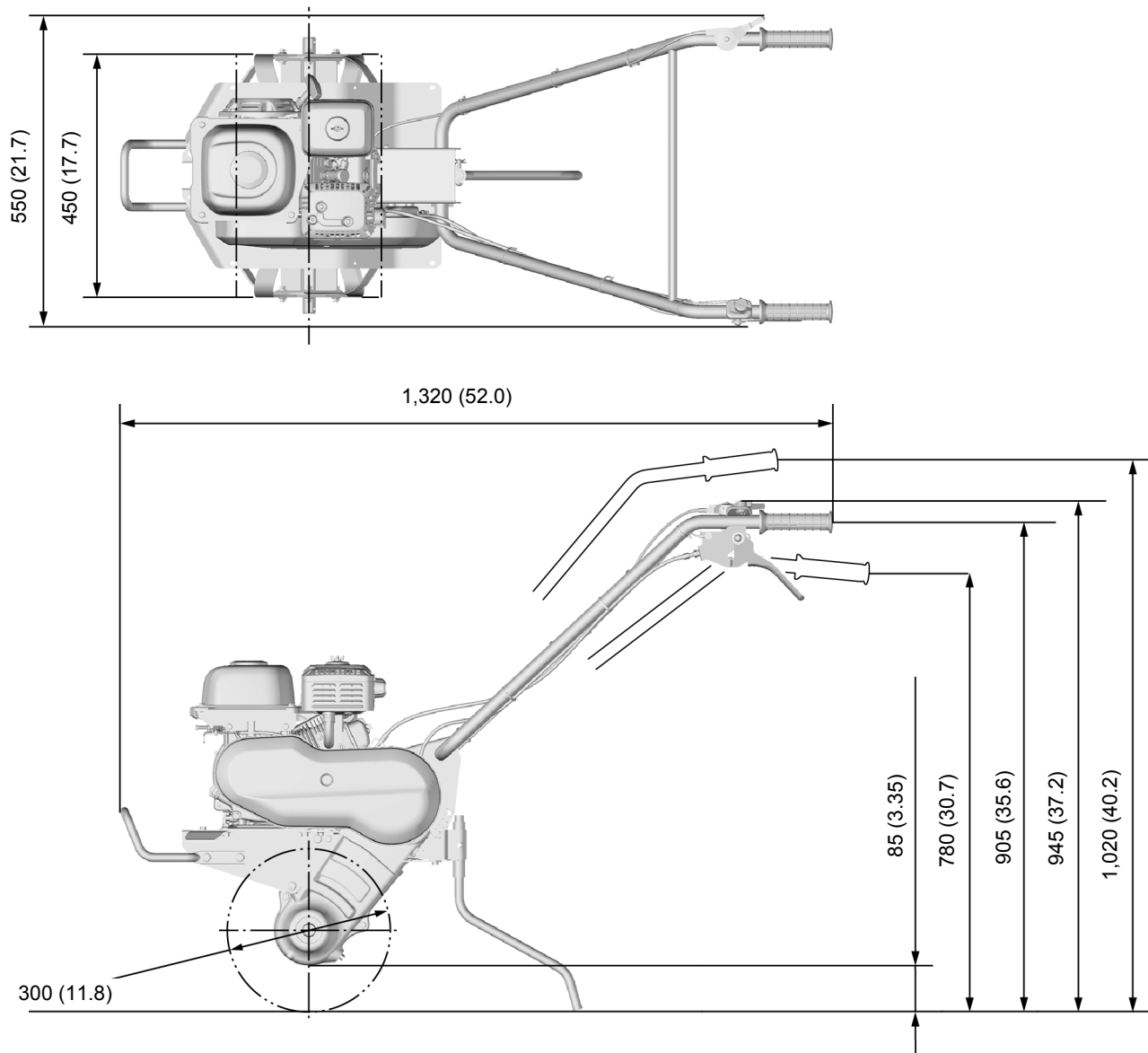

The dimensions above are determined when tines of each rotor are put on a level surface and an engine bed is parallel to the surface.

*: The overall length and height above are determined when the tightening position of a handle pipe is set in the middle of a vertical movable range.

SPECIFICATIONS

T, KW TYPE

Unit: mm (in)

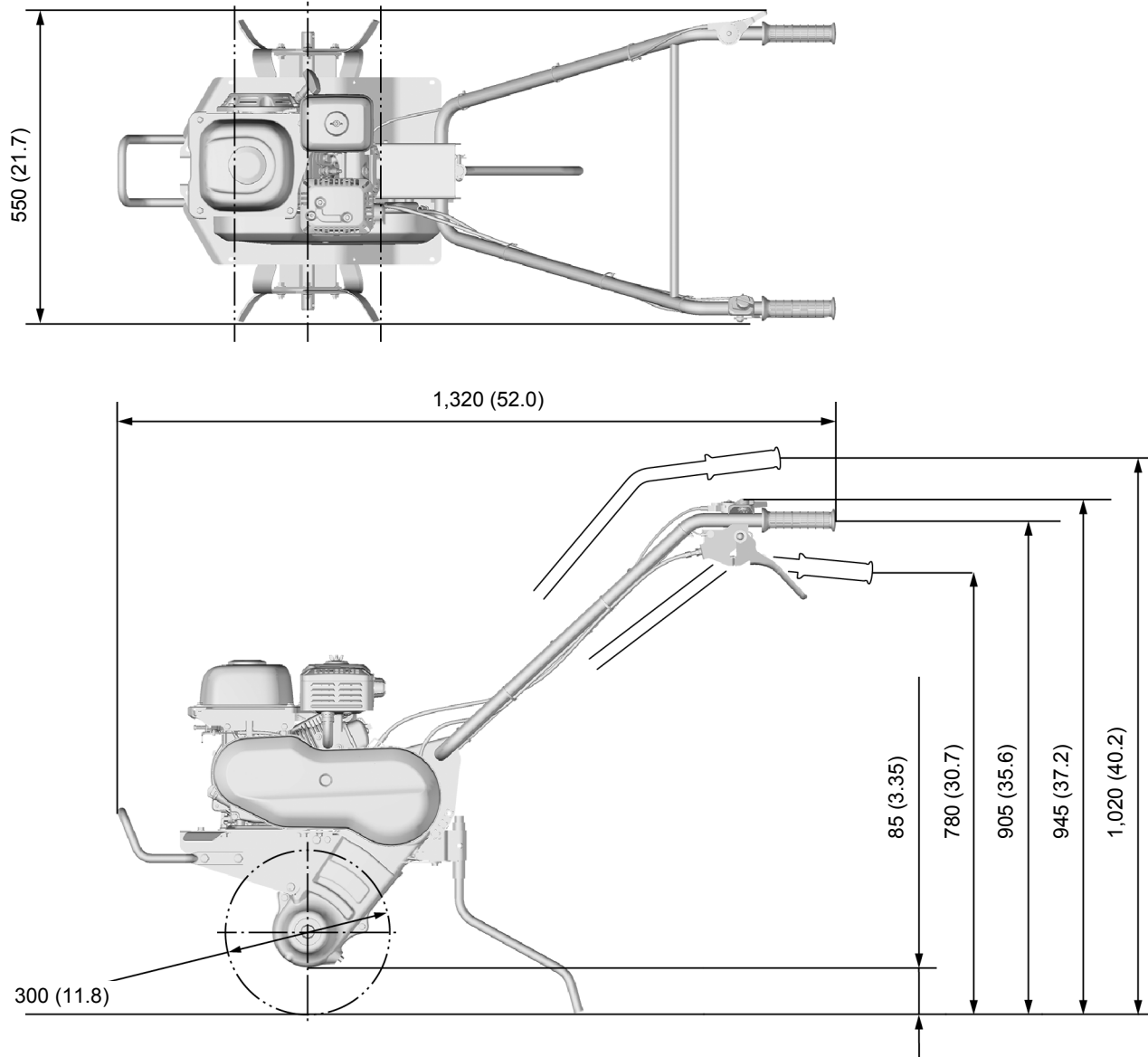

The dimensions above are determined when tines of each rotor are put on a level surface and an engine bed is parallel to the surface.

*: The overall length and height above are determined when the tightening position of a handle pipe is set in the middle of a vertical movable range.

SPECIFICATIONS

WIRING DIAGRAM

BI: BLACK
G: GREEN

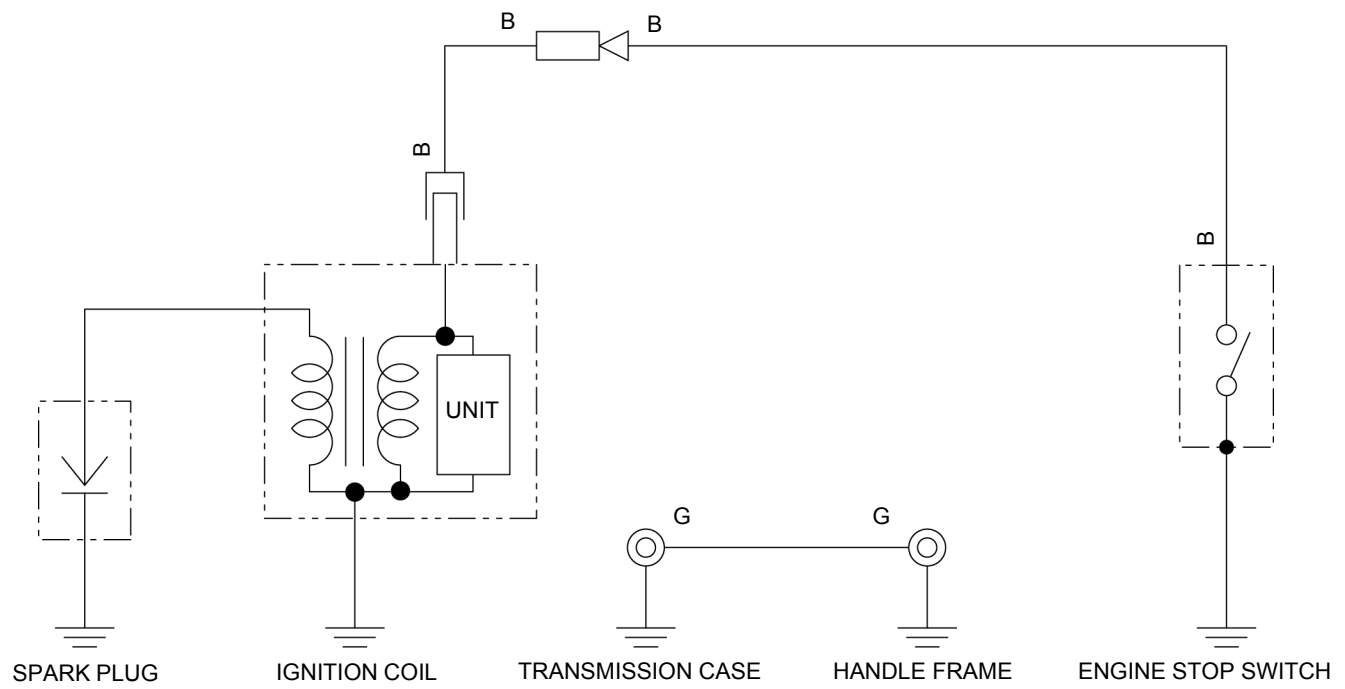

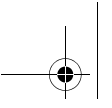

MEMO

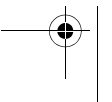
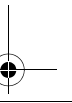
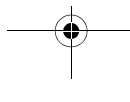
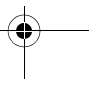
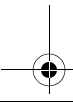
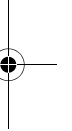
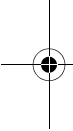

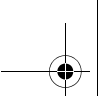

2. SERVICE INFORMATION

2

MAINTENANCE STANDARDS	2-2	TOOLS	2-5
TORQUE VALUES	2-3	CABLE/HARNESS ROUTING	2-7
LUBRICATION & SEAL POINT	2-4	TUBE ROUTING	2-8

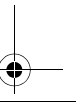
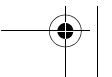
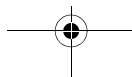
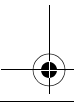
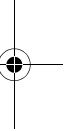
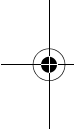

2-1

SERVICE INFORMATION

MAINTENANCE STANDARDS

ENGINE

Unit: mm (in)

Part	Item	Standard	Service limit	
Engine	Idle speed	1,850 – 2,150 min ⁻¹ (rpm)	–	
	Maximum engine speed (at no load)	3,800 – 4,000 min ⁻¹ (rpm)	–	
	Cylinder compression	0.50 MPa (51 kgf/cm ² , 72.5 psi)/600 min ⁻¹ (rpm)	–	
Cylinder	Sleeve I.D.	46.000 – 46.015 (1.8100 – 1.8116)	46.15 (1.8169)	
Cylinder head	Warpage	–	0.10 (0.004)	
Piston	Skirt O.D. at 10 mm (0.4 in) from bottom	45.965 – 45.985 (1.8096 – 1.8104)	45.87 (1.8059)	
	Piston-to-cylinder clearance	0.015 – 0.050 (0.0006 – 0.0019)	0.12 (0.0047)	
	Piston pin bore I.D.	12.002 – 12.008 (0.4725 – 0.4727)	12.04 (0.474)	
Piston pin	Pin O.D.	11.994 – 12.000 (0.4722 – 0.47)	11.97 (0.4713)	
	Piston pin-to-piston pin bore clearance	0.002 – 0.014 (0.0001 – 0.0006)	0.07 (0.0028)	
Piston rings	Ring side clearance	Top	0.035 – 0.070 (0.0014 – 0.0028)	0.20 (0.008)
		Second	0.045 – 0.080 (0.0018 – 0.0032)	0.20 (0.008)
	Ring end gap	Top	0.15 – 0.35 (0.0059 – 0.0138)	1.0 (0.04)
		Second	0.15 – 0.45 (0.0059 – 0.177)	1.0 (0.04)
		Oil (side rail)	0.10 – 0.70 (0.004 – 0.0276)	2.0 (0.08)
	Ring width	Top	0.970 – 0.995 (0.0382 – 0.0392)	0.968 (0.0381)
Second		0.940 – 0.960 (0.037 – 0.0378)	0.938 (0.0369)	
Connecting rod	Small end I.D.	12.005 – 12.020 (0.4726 – 0.4732)	12.07 (0.4752)	
	Big end I.D.	20.016 – 20.027 (0.7880 – 0.7885)	20.07 (0.7902)	
	Big end oil clearance	0.036 – 0.057 (0.0014 – 0.0022)	0.10 (0.004)	
	Big end side clearance	0.10 – 0.40 (0.004 – 0.016)	0.60 (0.024)	
Crankshaft	Crankpin O.D.	19.970 – 19.980 (0.7862 – 0.7866)	19.93 (0.7846)	
Valves	Valve clearance	IN	0.10 ± 0.02 (0.004 ± 0.001)	–
		EX	0.15 ± 0.02 (0.006 ± 0.001)	–
	Valve stem O.D.	IN	4.975 – 4.990 (0.1959 – 0.1965)	4.97 (0.1957)
		EX	4.960 – 4.970 (0.1953 – 0.1957)	4.95 (0.1949)
	Guide-to-stem clearance	IN	0.010 – 0.037 (0.004 – 0.0015)	0.060 (0.0024)
		EX	0.030 – 0.057 (0.0012 – 0.0022)	0.080 (0.0032)
	Valve guide I.D.	IN/EX	5.000 – 5.012 (0.1969 – 0.1973)	5.03 (0.198)
	Valve guide installation height	IN	5.8 – 6.2 (0.23 – 0.24)	–
		EX	3.3 – 3.7 (0.13 – 0.15)	–
	Valve seat width		0.7 – 0.9 (0.028 – 0.035)	2.0 (0.08)
	Valve spring free length		29.5 (1.161)	28.3 (1.114)
	Valve spring perpendicularity		–	2° max.
	Valve lifter I.D. (cylinder block)		6.500 – 6.515 (0.256 – 0.2565)	6.53 (0.2571)
Valve lifter shaft O.D.		6.475 – 6.495 (0.2549 – 0.2557)	6.46 (0.2543)	
Camshaft	Camshaft O.D.	9.972 – 9.987 (0.3926 – 0.3932)	9.95 (0.3917)	
	Cam height	IN	19.599 – 19.999 (0.7716 – 0.7874)	19.40 (0.764)
		EX	19.641 – 20.041 (0.7733 – 0.789)	19.44 (0.7654)
Rocker arm Rocker shaft	Rocker arm I.D.	6.000 – 6.030 (0.24 – 0.2374)	6.04 (0.2378)	
	Rocker arm shaft O.D.	5.952 – 6.000 (0.2343 – 0.24)	5.94 (0.234)	
	Rocker arm shaft bearing I.D. (cylinder head)	6.010 – 6.022 (0.2366 – 0.2371)	6.04 (0.2378)	
Cylinder block	Camshaft holder I.D.	10.000 – 10.015 (0.39 – 0.3943)	10.05 (0.3957)	
Crankcase cover	Camshaft holder I.D.	10.000 – 10.015 (0.39 – 0.3943)	10.05 (0.3957)	
Spark plug	Gap	0.6 – 0.7 (0.024 – 0.028)	–	
Spark plug cap	Resistance	7.5 – 12.5 kΩ	–	
Ignition coil	Resistance	Primary side	0.8 – 1.2 Ω	–
		Secondary side	5.6 – 11.8 kΩ	–
	Air gap		0.2 – 0.6 (0.008 – 0.024)	–
Carburetor	Main jet	#55	–	
	Float level height	20.2 (0.795)	–	
	Pilot screw opening	1 3/8	–	

SERVICE INFORMATION

FRAME

Unit: mm (in)

Part	Item	Standard	Service limit	
V-belt	Distance L between upper and lower belt runs	55 – 62 (2.17 – 2.44)	–	
	Belt stopper clearance	A	1 – 2 (0.04 – 0.08)	–
		B	3 – 5 (0.12 – 0.20)	–
		C	6 – 8 (0.24 – 0.31)	–
		D	2 – 4 (0.08 – 0.16)	–
E		2 – 4 (0.08 – 0.16)	–	
Throttle	Lever freeplay	5.0 – 10 (0.2 – 0.39)	–	
Clutch	Lever freeplay	5.0 – 15.0 (0.2 – 0.59)	–	

TORQUE VALUES

ENGINE TORQUE VALUES

Item	Tread Dia.	Torque values			Remarks
	mm	N·m	kgf·m	lbf·ft	
Cylinder head bolt	M6 x 1.0	9.5	0.97	7.0	Apply engine oil to the bolt threads and seating surface.
Rocker arm pivot lock nut	M5 x 0.5	7	0.71	5.2	
Crankcase cover bolt	M6 x 1.0	12	1.2	9	
Engine oil drain bolt	M10 x 1.25	17.5	1.78	12.9	
Connecting rod bolt	M5 x 0.8	5	0.51	3.7	Apply engine oil to the bolt threads and seating surface.
Spark plug	M10 x 1.0	12	1.2	9	
Flywheel nut	M12 x 1.25	60	6.1	44	Apply engine oil to the bolt threads and seating surface.
Head cover bolt	M6 x 1.0	10	1.0	7	
Fuel cock screw	M5 x 0.8	2.3	0.23	1.7	
Carburetor	M6 x 1.0	8.5	0.87	6.3	

FRAME TORQUE VALUES

Item	Tread Dia.	Torque values			Remarks
	mm	N·m	kgf·m	lbf·ft	
Transmission oil drain bolt	M10 x 1.25	17.5	1.78	12.9	
Tension arm shaft	M8 x 1.25	27	2.8	20	

SERVICE INFORMATION**STANDARD TORQUE VALUES****ENGINE**

Item	Tread Dia.	Torque values			Remarks
		N·m	kgf·m	lbf·ft	
Flange bolt and nut	5 mm	5.2	0.53	3.8	
	6 mm	12	1.2	9	
	8 mm	23	2.3	17	
	10 mm	40	4.1	30	
SH (Small head) flange bolt	6 mm	9	0.92	6.6	
CT (Cutting threads) flange bolt (Retightening)	5 mm	5.4	0.55	4	
	6 mm	12	1.2	9	

FRAME

Item	Tread Dia.	Torque values			Remarks
		N·m	kgf·m	lbf·ft	
Screw	5 mm	4.2	0.43	3.1	
Flange bolt and nut	5 mm	5.5	0.56	4.1	
	6 mm	11.9	1.2	8.8	
	8 mm	26.5	2.7	19.5	
	10 mm	39	4	29	
CT (Cutting threads) flange bolt (Retightening)	6 mm	9.9	1	7.3	

LUBRICATION & SEAL POINT**ENGINE**









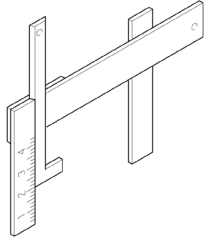

Material	Location	Remarks
Engine oil	Crankshaft pin and gear teeth	
	Piston outer surface, ring groove and piston pin hole	
	Piston ring whole surface	
	Cylinder inner surface	
	Connecting rod big and small end bearing	
	Connecting rod bolt threads and seating surface	
	Camshaft cam profile and journal	
	Valve lifter stem, stem end and slipper surface	
	Valve stem sliding surface and stem end	
	Rocker arm tappet surface and pivot	
	Rocker arm pivot threads and seating surface	
	Flywheel nut threads and seating surface	
	Cylinder head bolt threads and seating surface	
	Governor weight holder gear and sliding surface	
	Governor shaft journal	
	Governor arm shaft journal	
Multi-purpose grease	Recoil starter case starter pulley sliding surface	
	Ratchet sliding surface	
	Spring retainer inside	
	O-ring whole surface	
	Oil seal lips	

FRAME

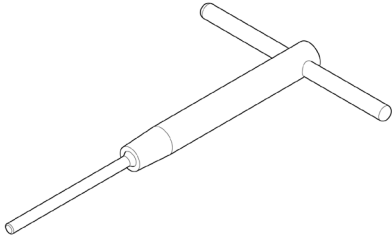
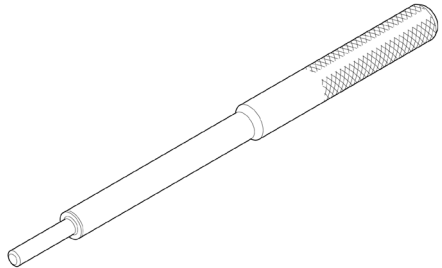
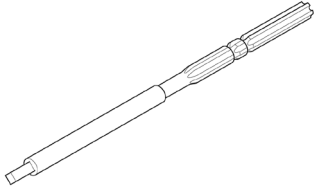
Material	Location	Remarks
Transmission oil	Transmission oil filler cap and O-ring whole surface	
Shell Alvania grease RA or equivalent	Clutch lever pin and sliding surface	
	Tension arm shaft and tension arm sliding surface	
	Throttle lever control plate and sliding surface	
CEMEDINE #540 or equivalent	Handle grip inside	

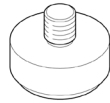
SERVICE INFORMATION

TOOLS

<p>Float level gauge 07401-0010000</p> 	<p>Seat cutter, 20.5 mm (45° IN/EX) 07780-0011000</p> 	<p>Flat cutter, 20 mm (32° IN/EX) 07780-0013200</p> 
<p>Interior cutter, 20.5 mm (60° IN/EX) 07780-0014300</p> 	<p>Cutter holder, 5.0 mm 07781-0010400</p> 	<p>Valve guide driver, 5 mm 07492-MA600000</p> 
<p>Valve guide reamer 5.010 mm 07984-MA60001</p> 	<p>Pilot, 17 mm 07746-0040400</p> 	<p>Pilot, 28 mm 07746-0041100</p> 
<p>Attachment 37 × 40 mm 07746-0010200</p> 	<p>Attachment 27 × 30 mm 07946-1870100</p> 	<p>Inner bearing drive attachment 17 mm 07746-0020300</p> 

SERVICE INFORMATION

Driver
07749-0010000

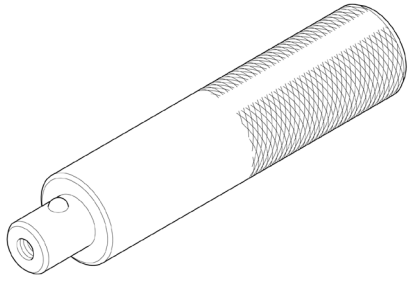

Driver, 22 mm I.D.
07746-0020100

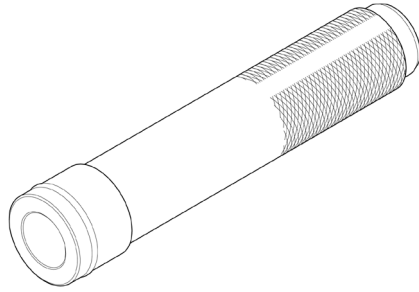

SERVICE INFORMATION

CABLE/HARNESS ROUTING

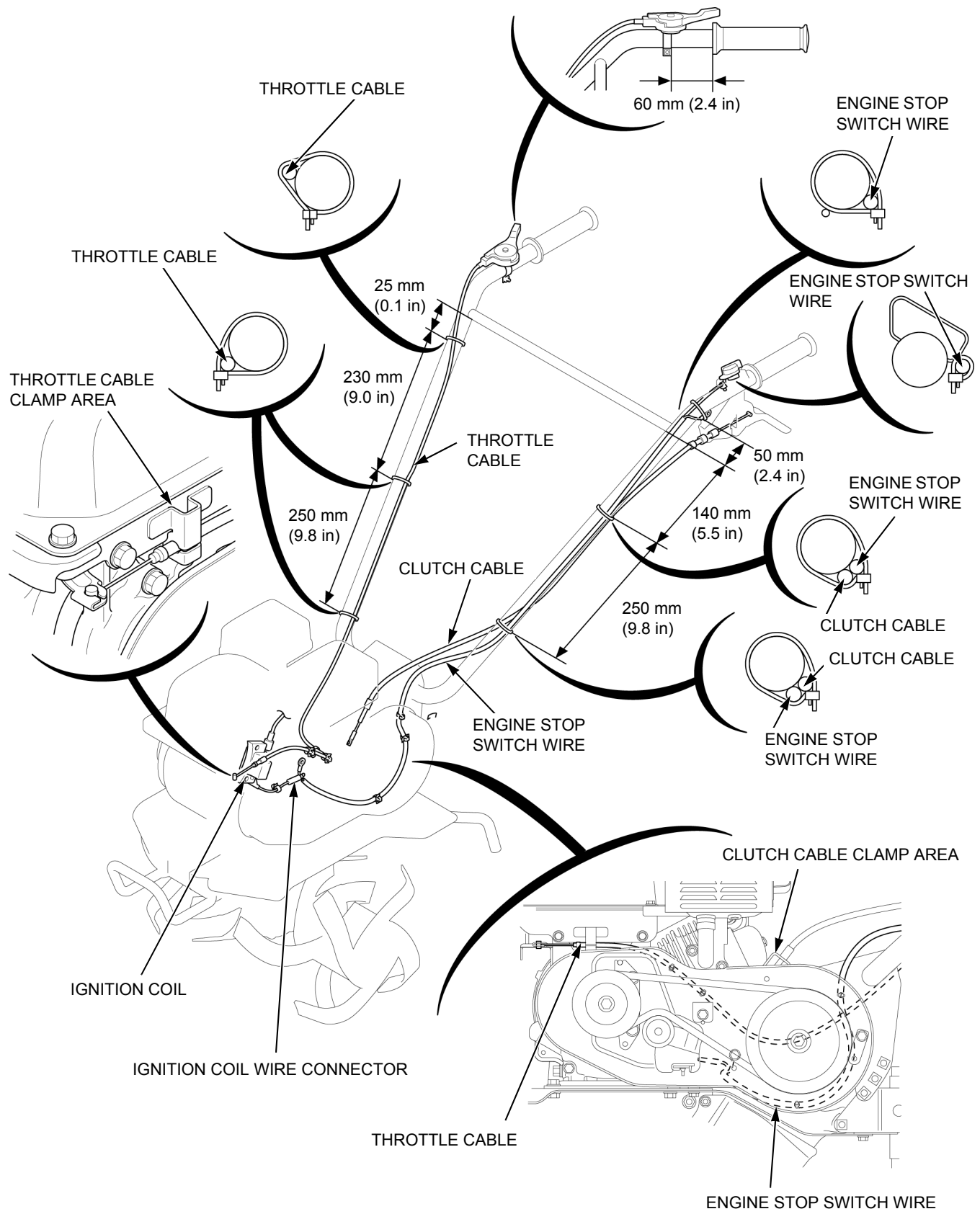

SERVICE INFORMATION

TUBE ROUTING

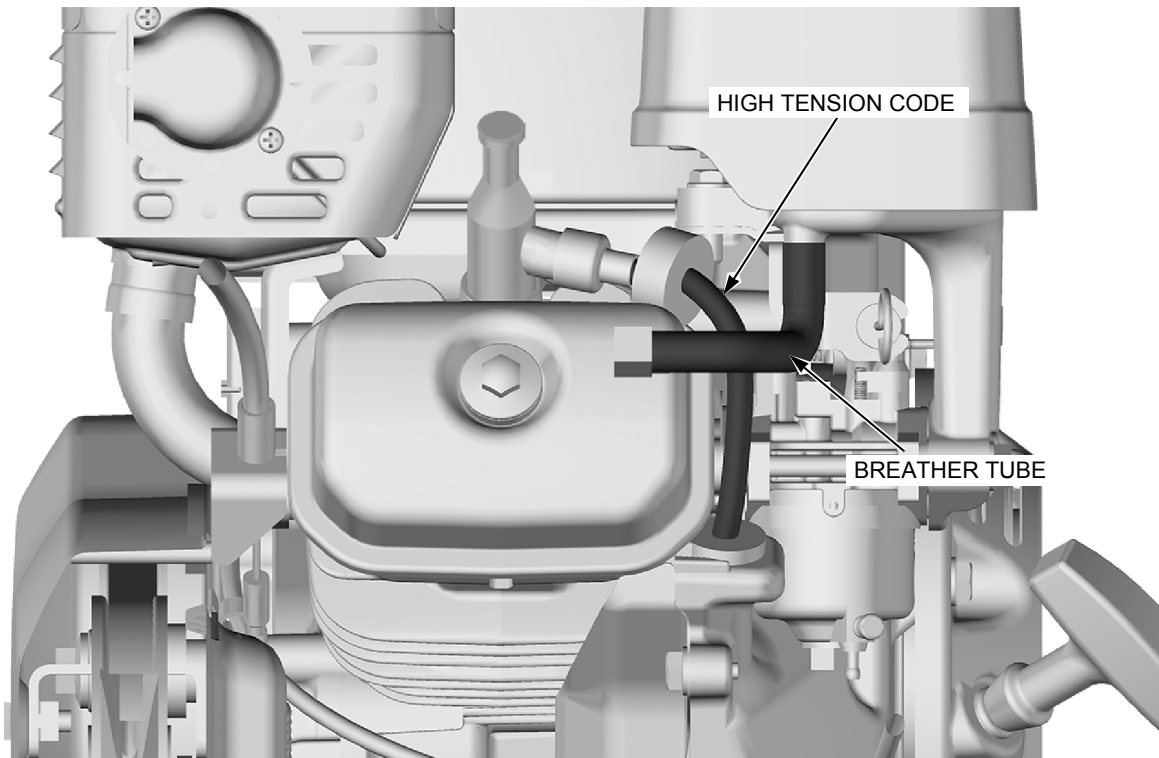
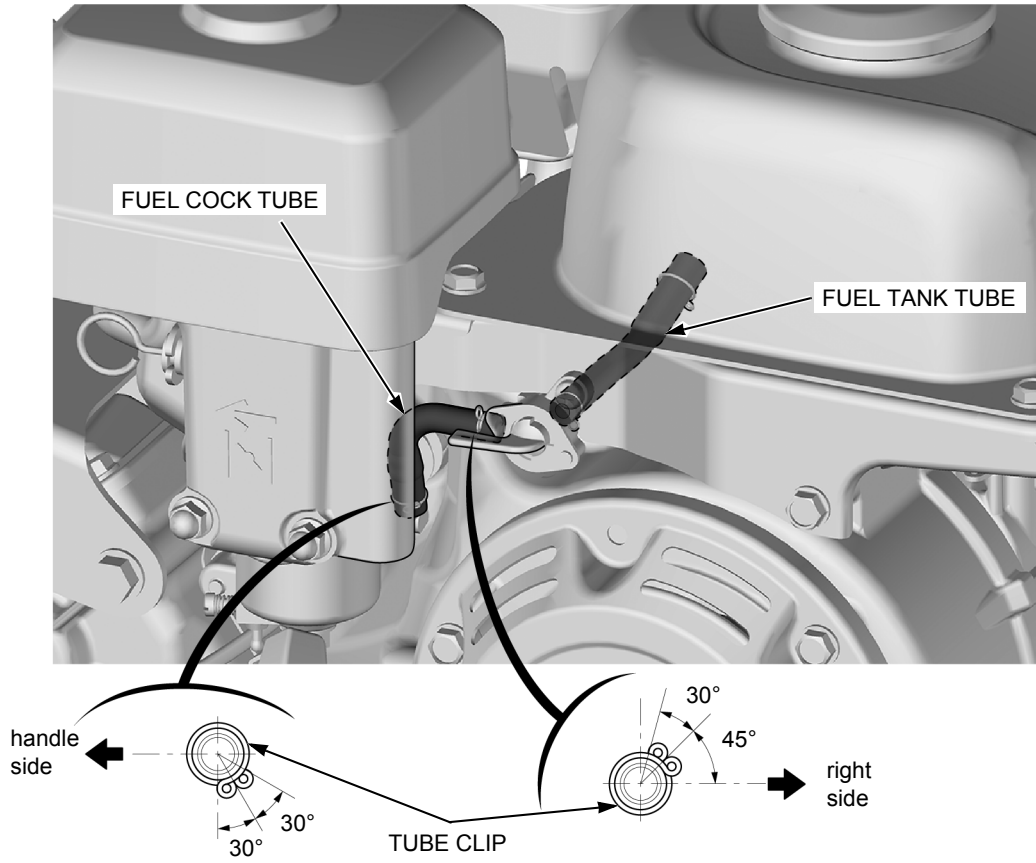

3. MAINTENANCE

3

MAINTENANCE SCHEDULE.....	3-2	THROTTLE CABLE CHECK/ ADJUSTMENT	3-10
ENGINE OIL LEVEL CHECK.....	3-3	ENGINE IDLE SPEED CHECK/ ADJUSTMENT	3-10
ENGINE OIL CHANGE.....	3-4	CLUTCH CABLE CHECK/ ADJUSTMENT	3-10
AIR CLEANER CHECK/CLEANING/ REPLACEMENT.....	3-5	BELT TENSION CHECK/ADJUSTMENT ...	3-11
BOLTS AND NUTS TIGHTNESS.....	3-6	VALVE CLEARANCE CHECK/ ADJUSTMENT	3-14
TRANSMISSION OIL LEVEL CHECK	3-6	COMBUSTION CHAMBER CLEANING	3-15
TRANSMISSION OIL CHANGE	3-7	FUEL TANK AND STRAINER CLEANING	3-15
GREASE APPLICATION.....	3-8	FUEL TUBE CHECK.....	3-15
SPARK PLUG CHECK/ADJUSTMENT/ REPLACEMENT.....	3-9		

3-1

MAINTENANCE**MAINTENANCE SCHEDULE**

ITEM	REGULAR SERVICE PERIOD (1)						Refer to page	
	After storage	○ Each use	First month or 20 hrs.	Every 3 months or 50 hrs.	Every 6 months or 100 hrs.	Every year or 300 hrs.		
Engine oil	Check-Level		○				3-3	
	Change	○		○		○	3-4	
Air cleaner	Check		○				3-5	
	Clean				○ (2)		3-5	
	Replace					○	3-5	
Tiller outside	Check		○				-	
Throttle lever function	Check		○				-	
Bolts and nuts tightness	Check		○				3-6	
Wiring and cables	Check		○				2-7	
Engine operation	Check		○				-	
Recoil starter cover	Check-Clean		○				-	
Clutch lever function	Check-Clean			○			-	
	Grease lubricate	○ (3)					3-8	
Transmission oil	Check-Level	○		○		○	3-6	
Grease application	Grease lubricate	○					3-8	
Spark plug	Check-Adjust					○	3-9	
	Replace					○	3-9	
Throttle cable	Check-Adjust					○	3-10	
Idle speed	Check-Adjust					○	3-10	
Clutch cable	Check-Adjust			○		○	3-10	
Belt tension	Check-Adjust			○ (4)		○ (4)	3-11	
Valve clearance	Check-Adjust					○	3-14	
Combustion chamber	Clean	After every 500 hrs (3)						3-15
Fuel tank and filter	Clean	○				○	3-15	
Governor arm	Clean	○				○	6-2	
Fuel tube	Check	Every 2 years (Replace if necessary)						3-15

(1) For commercial use, log hours of operation to determine proper maintenance intervals.

(2) Service every 10 operating hours or every day when used in dusty areas.

(3) Apply grease to the pin part of the clutch lever fulcrum and so on for prevention of rust when you keep it for a long time (more than 30 days).

(4) Check that there are no cracks and abnormal wear in the belt, and replace it if necessary.

ENGINE OIL LEVEL CHECK

NOTICE

- Check the engine oil level with the engine stopped.

Put the tiller horizontally on a firm level surface.

Remove the oil filler cap/dipstick [1] and wipe the dipstick clean.

Insert the oil filler cap/dipstick in the oil filler neck, but do not screw it in.

Remove the oil filler cap/dipstick and check the oil level.

If the oil level is near or below the lower level [2] on the dipstick, fill with the recommended engine oil to the upper level (top of the oil filler neck) [3].

RECOMMENDED ENGINE OIL:

SAE 10W-30

API service classification SE or higher

Oil is a major factor affecting performance and service life. Use 4-stroke automotive detergent oil.

SAE 10W-30 is recommended for general use. Other viscosities shown in the chart may be used when the average temperature in your area is within the recommended range.

Check that the O-ring [4] is in good condition, replace it if necessary.

Apply engine oil to the O-ring whole surface.

Install the oil filler cap/dipstick securely.

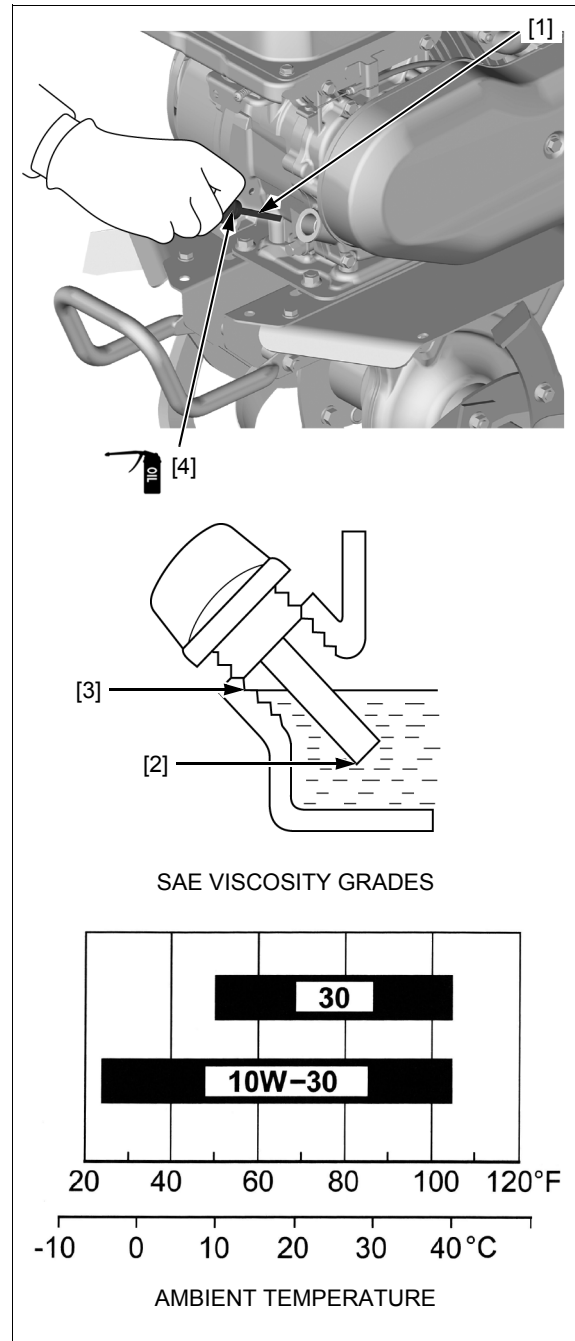

MAINTENANCE

ENGINE OIL CHANGE

NOTE:

- Drain the used engine oil while the engine is warm.
Warm oil drains quickly and completely.

Place the tiller on a firm level surface, and place a suitable container [1] under the engine oil drain bolt (10 x 15 mm) [2].

Remove the oil filler cap/dipstick [3], drain bolt and sealing washer (10 mm) [4] and drain the engine oil into the suitable container.

Please dispose of used engine oil in a manner that is compatible with the environment. We suggest you take used oil in a sealed container to your local recycling center or service station for reclamation. Do not throw it in the trash, pour it on the ground, or pour it down a drain.

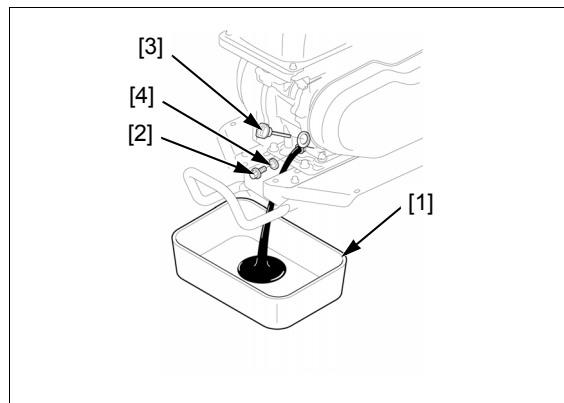

CAUTION

Used engine oil contains substances that have been identified as carcinogenic. If repeatedly left in contact with the skin for prolonged periods, it may cause skin cancer. Wash your hands thoroughly with soap and water as soon as possible after contact with used engine oil.

Install the drain bolt and new sealing washer. Tighten the drain bolt to the specified torque.

TORQUE: 17.5 N·m (1.78 kgf·m, 12.9 lbf·ft)

Fill the recommended engine oil (page 3-3).

ENGINE OIL CAPACITY:

0.36 liter (0.38 US qt, 0.32 Imp qt)

Install the oil filler cap/dipstick securely.

Recheck the engine oil level (page 3-3).

Make sure there are no engine oil leaks.

AIR CLEANER CHECK/CLEANING/ REPLACEMENT

NOTE:

- A dirty air cleaner element will restrict air flow to the carburetor, reducing engine performance. If the engine is operated in dusty areas, clean the air cleaner element more often than specified in the "MAINTENANCE SCHEDULE" (page 3-2).

NOTICE

- *Operating the engine without an air cleaner element or with a damaged air cleaner element, will allow dirt to enter the engine, causing rapid engine wear.*

Remove the air cleaner cover wing nut [1] and the air cleaner cover [2].

Remove the element wing nut [3].

Remove the air filter element [4] and the air cleaner undercover [5] together. Be careful not to let any dust fall into the air cleaner elbow intake hole [6].

Detach the grommet [7], the foam element [8], the paper element [9], and the air cleaner undercover.

Remove the elbow packing [10] from the air cleaner elbow [11].

Check both the elements for holes or tears thoroughly and replace them if they are damaged.

Check the air cleaner elbow packing for deterioration or damage.

Wipe dirt from the inside of the air cleaner cover, the elbow packing, the air cleaner undercover, and the air cleaner elbow with a moist rag.

Be careful to prevent dirt from entering the air cleaner elbow that leads to the carburetor.

Install the air filter elements and the grommet, and then tighten the element wing nut until its seating surface reaches the grommet. Then, turn the element wing nut twice (720 degrees).

Install the air cleaner cover, and then tighten the air cleaner cover wing nut until its seating surface reaches the cover. Then, turn the air cleaner cover wing nut once (360 degrees).

Clean the foam element [1] in warm soapy water, rinse and dry it thoroughly, or clean it with a high flash point solvent [2] and dry it thoroughly.

Dip the form element in clean engine oil [3] and squeeze out all the excess oil.

Excess oil will restrict the air flow through the form element and may cause the engine to smoke at startup.

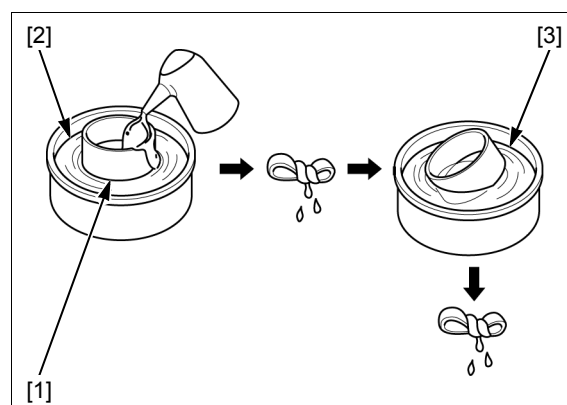
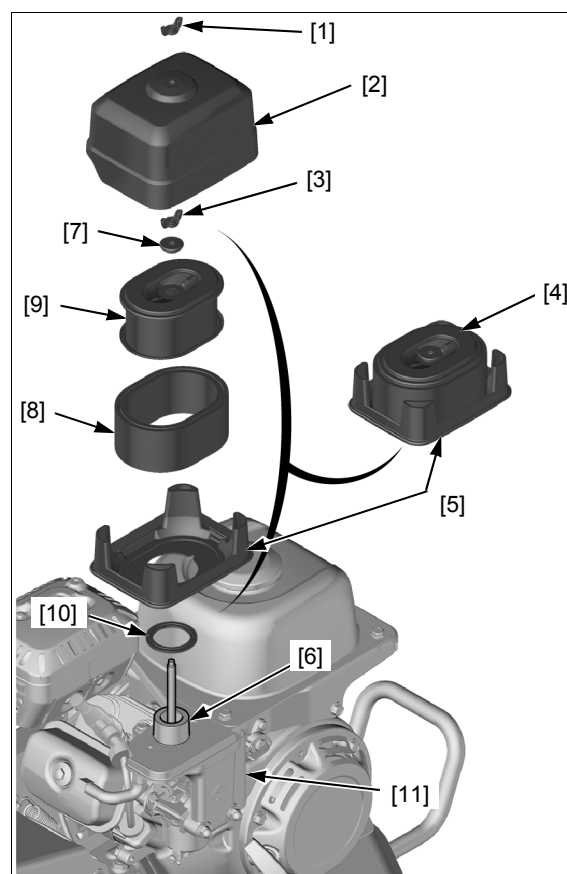

MAINTENANCE

Tap the paper element [1] several times on a hard surface to remove dirt, or blow it from the inside with compressed air (not exceeding 207 kPa, 2.1 kgf/cm², 30 psi).

Never try to brush off dirt; dirt may be mixed in the paper fibers.

Assemble the air cleaner in the reverse order of disassembly.

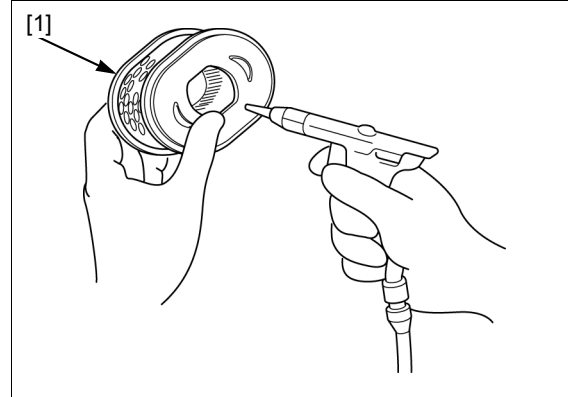

BOLTS AND NUTS TIGHTNESS

Check that all chassis nuts and bolts are tight to their correct torque values (page 2-3).

Check that all split pins, safety clips, hose clamps and cable stays are in place and properly secured.

TRANSMISSION OIL LEVEL CHECK

NOTICE

- Check the transmission oil level with the engine stopped.

Place the tiller on a firm level surface with the rotor set on the ground so that the engine becomes level.

Remove the oil filler cap [1] and check that the oil level is up to the lower edge [2] of the oil filler hole.

If the level is low, fill it with the recommended transmission oil to the upper level (up to the lower edge of the oil filler hole).

RECOMMENDED TRANSMISSION OIL:
SAE 10W-30
API service classification SE or higher

Check that the O-ring [3] is in good condition.

Replace it if necessary.

Apply transmission oil to the O-ring whole surface.

Install the oil filler cap securely.

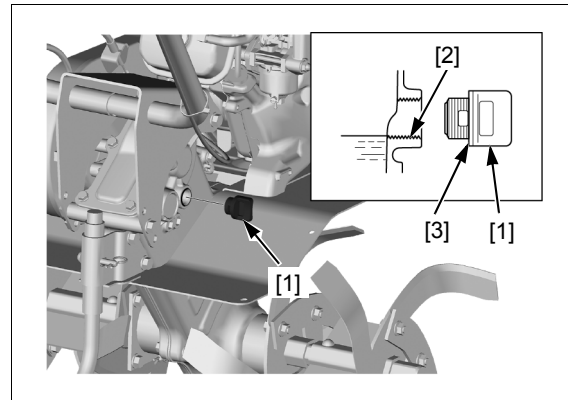

TRANSMISSION OIL CHANGE

NOTE:

- The transmission oil is the same as engine oil.
- Drain the used engine oil while the engine is warm.
Warm oil drains quickly and completely.

Place the tiller on a firm level surface, and place a suitable container [1] under the mission oil drain bolt (10 x 15 mm) [2].

Remove the oil filler cap [3], drain bolt and sealing washer (10 mm) [4] and drain the transmission oil into the suitable container.

Please dispose of used transmission oil in a manner that is compatible with the environment. We suggest you take used oil in a sealed container to your local recycling center or service station for reclamation. Do not throw it in the trash, pour it on the ground, or pour it down a drain.

⚠ CAUTION

Used engine oil contains substances that have been identified as carcinogenic. If repeatedly left in contact with the skin for prolonged periods, it may cause skin cancer. Wash your hands thoroughly with soap and water as soon as possible after contact with used engine oil.

Install the drain bolt and new sealing washer. Tighten the drain bolt to the specified torque.

TORQUE: 17.5 N·m (1.78 kgf·m, 12.9 lbf·ft)

Fill the recommended engine oil (page 3-6).

ENGINE OIL CAPACITY:

1.0 liter (1.1 US qt, 0.9 Imp qt)

Install the oil filler cap securely.

Recheck the mission oil level (page 3-6).

Make sure there are no engine oil leaks.

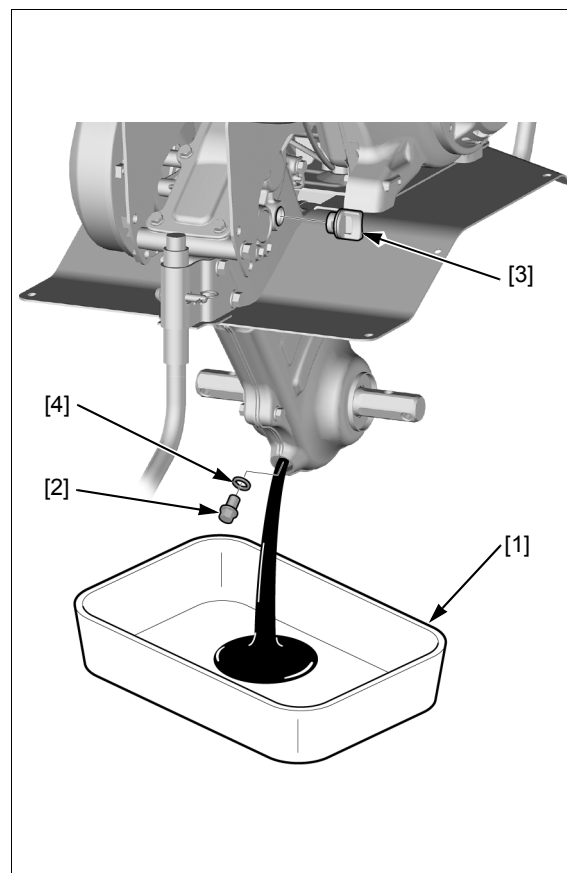

MAINTENANCE

GREASE APPLICATION

Apply grease to the following parts:

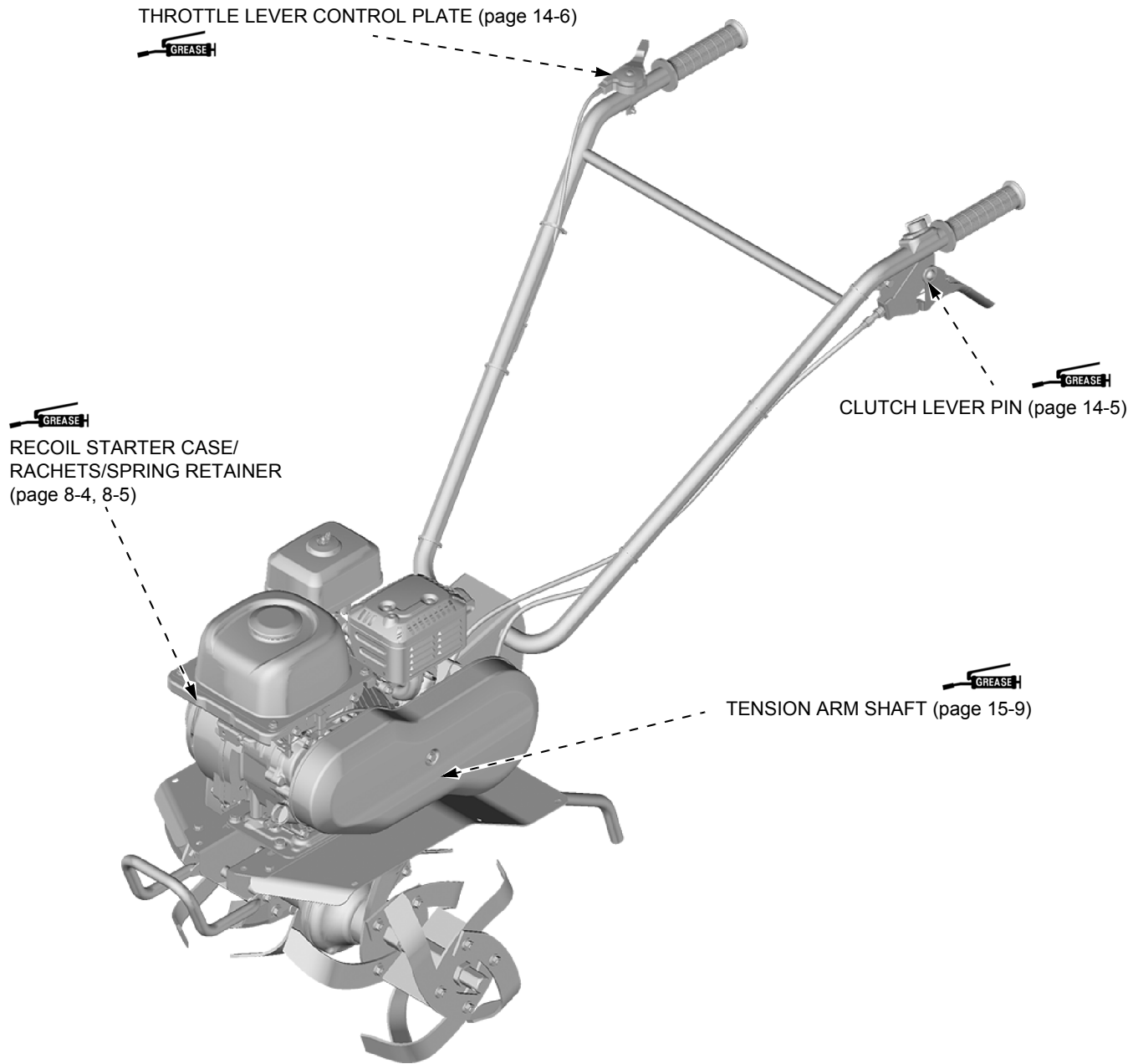

MAINTENANCE

SPARK PLUG CHECK/ADJUSTMENT/REPLACEMENT**⚠ CAUTION**

If the engine has been running, the engine will be very hot. Allow it to cool before proceeding.

- Clean any dirt from around the spark plug [1].
- Disconnect the spark plug cap [2].
- Remove the spark plug with a spark plug wrench.

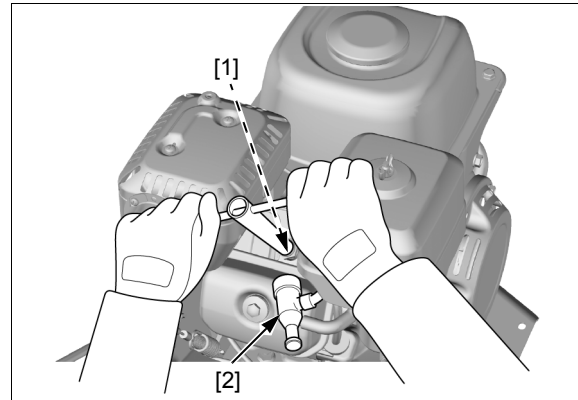

Visually inspect the spark plug. Replace the plug if the insulator [1] is cracked or chipped.

Remove carbon or other deposits using a wire brush.

Check the sealing washer [2], center electrode [3] and side electrode [4] for damage.

NOTICE

- *An incorrect spark plug can cause engine damage. Use the recommended spark plug or an exact equivalent.*
- *Replace the spark plug if the sealing washer is damaged.*

RECOMMENDED SPARK PLUG: C4HSB (NGK)

Measure the plug gap with a thickness gauge. If the measurement is out of the specification, adjust the gap by bending the side electrode.

SPARK PLUG GAP: 0.60 – 0.70 mm (0.024 – 0.028 in)

Loosely install the spark plug by hands, and then tighten it to the specified torque.

TORQUE: 12 N·m (1.2 kgf·m, 9 lbf·ft)

NOTICE

- *A loose spark plug turns very hot and can damage the engine. Overtightening can damage the threads in the cylinder head.*

Connect the spark plug cap.

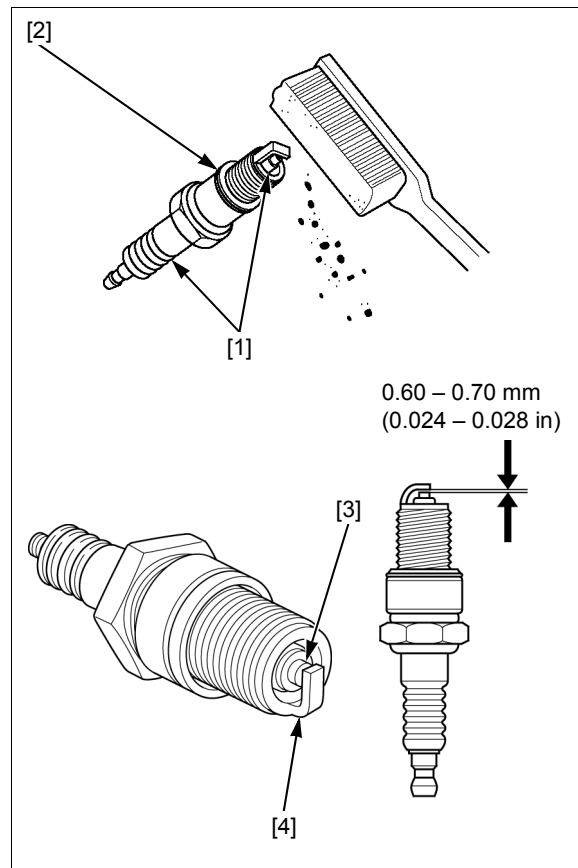

MAINTENANCE

THROTTLE CABLE CHECK/ADJUSTMENT

Check for any deterioration or damage to the throttle cable [1].

Check the throttle lever [2] for smooth operation.

Measure the throttle lever freeplay at the lever tip.

FREEPLAY: 5.0 – 10 mm (0.20 – 0.4 in)

If the throttle lever freeplay is out of specification, loosen the lock nut [3] and turn the adjusting nut [4] in or out as required.

After adjustment, tighten the lock nut securely.

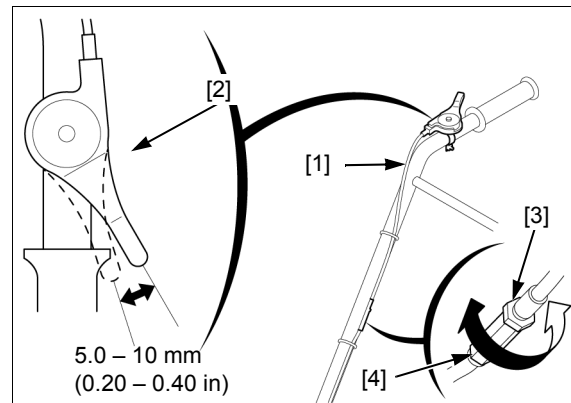

ENGINE IDLE SPEED CHECK/ADJUSTMENT

NOTE:

- Use a tachometer with graduations of 50 min^{-1} (rpm) or smaller that will accurately indicate a 50 min^{-1} (rpm) change.

Warm up the engine.

Stop the engine and connect a tachometer according to manufacturer's operating instruction.

Start the engine and check the idle speed.

LOW IDLE SPEED: 1,900 – 2,100 min^{-1} (rpm)

HIGH IDLE SPEED: 3,800 – 4,000 min^{-1} (rpm)

If the low idle speed is out of the specification, turn the throttle stop screw [1] to obtain the specified standard idle speed.

If the high idle speed is out of the specification, turn the throttle stop screw [2] to obtain the specified standard idle speed.

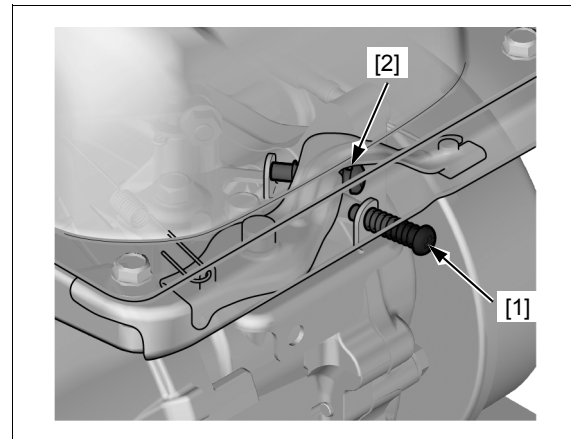

CLUTCH CABLE CHECK/ADJUSTMENT

CHECK

Check for any deterioration or damage to the clutch cable [1].

Squeeze the clutch lever [2] several times.

If there is a problem, adjust the clutch cable (page 3-11).

After that If there is still a problem, disassemble the clutch lever and clean the parts (page 14-5).

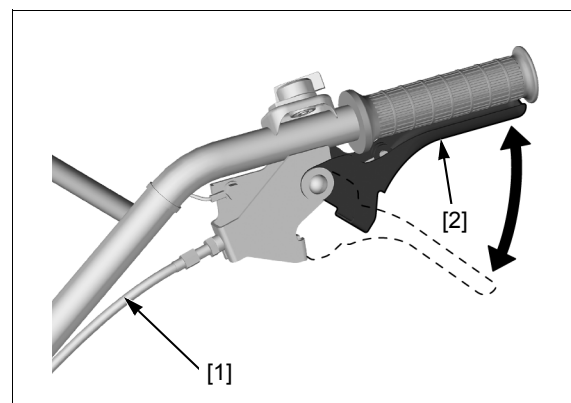

MAINTENANCE**ADJUSTMENT**

Measure the freeplay of the clutch lever [1].

FREEPLAY: 5.0 – 15.0 mm (0.20 – 0.59 in)

If adjustment is necessary, loosen the lock nut [2] and turn the adjusting bolt [3] in or out as required. After adjustment, tighten the lock nut.

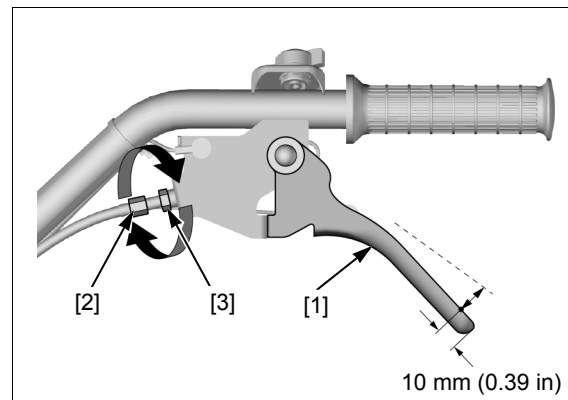
**BELT TENSION CHECK/ADJUSTMENT****CHECK**

Remove the belt cover (page 11-2).

Check that there is no crack and abnormal wear-out in the belt, and replace if it is abnormal (page 11-2).

Set the V-belt [1] so that the V-belt joint area [2] is not located between the drive pulley [3] and driven pulley [4].

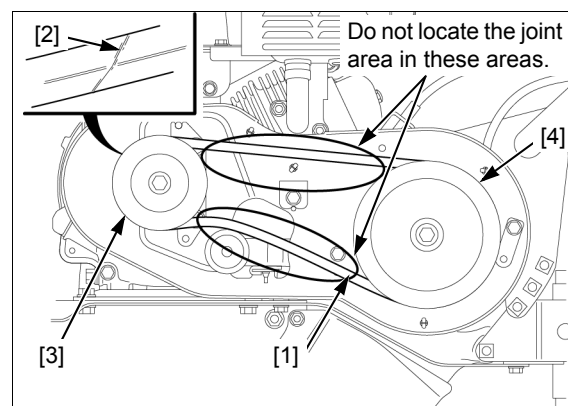

Squeeze the V-belt [1] by hands more than six times as shown.

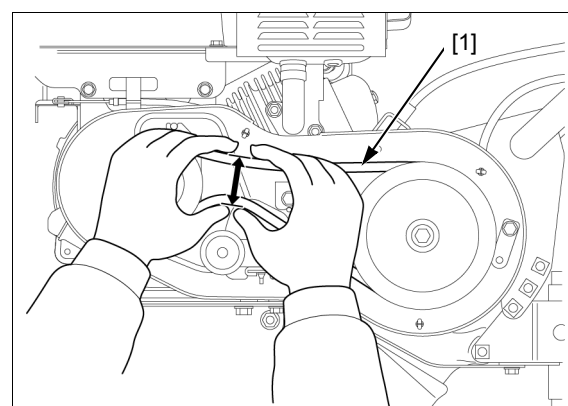

With the clutch engaged, measure the distance L [1] between the upper and lower belt that run at the belt tensioner.

SPECIFIED DISTANCE L: 55 – 62 mm (2.17 – 2.44 in)

If the measured distance L is within the specification, go to the belt stopper adjustment (page 3-13).

If the measured distance L is out of the specification, go to the belt tension adjustment (page 3-12).

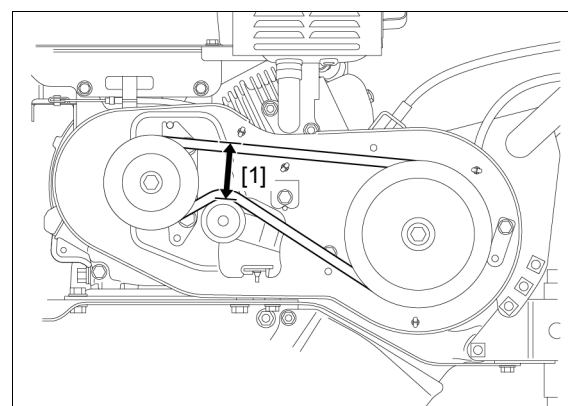

MAINTENANCE

BELT TENSION ADJUSTMENT

Loosen four engine mounting bolts (8 x 18 mm) [1] and nuts (8 mm) [2].

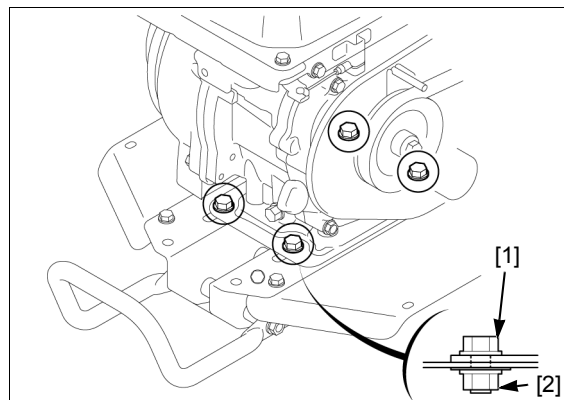

Referring to the chart below, adjust the distance ℓ [1] so that the distance L [2] is within the specification.

SPECIFIED DISTANCE L: 55 – 62 mm (2.17 – 2.44 in)

Distance L	Distance ℓ
-3.0 mm (0.12 in)	-2.0 mm (0.08 in)
-1.5 mm (0.06 in)	-1.0 mm (0.04 in)
+1.5 mm (0.06 in)	+1.0 mm (0.04 in)
+3.0 mm (0.12 in)	+2.0 mm (0.08 in)

Loosen the engine stay bolts (8 x 16 mm) [3] and adjust the distance ℓ by moving the engine back or forward.

After adjustment, tighten the engine stay bolts (8 x 16 mm) and four engine mounting bolts (8 x 18 mm), nuts (8 mm) and recheck the distance L.

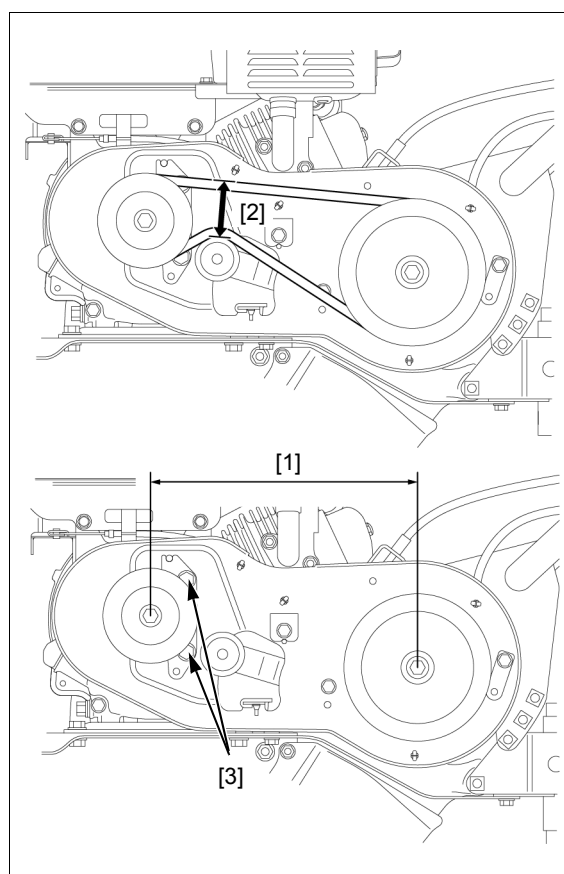

After adjusting the belt tension, check the drive pulley [1] and driven pulley [2] for proper alignment as shown.

NOTICE

- *Incorrect V-belt adjustment can cause belt damage and/or abnormal noise from the belt or pulleys.*

If the pulleys are not aligned, check the pulley bolts for tightness and the pulleys for possible distortion.

Tighten the engine stay bolt and engine mounting bolts securely.

Go to the belt stopper adjustment (page 3-13).

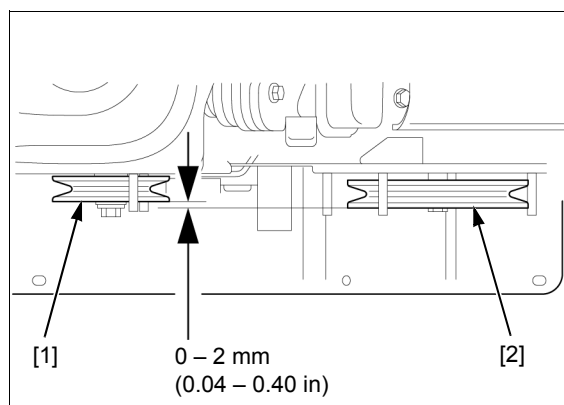

MAINTENANCE**BELT STOPPER ADJUSTMENT**

With the clutch engaged, measure the clearance between the V-belt [1] and belt stopper [2].

Movable mold stopper**STANDARD CLEARANCE:**

A: 1.0 – 2.0 mm (0.04 – 0.08 in)

To adjust the clearance, loosen belt stopper bolt (6 x 10 mm) [3], then move the stopper slide as necessary and tighten the stopper bolt securely.

After adjusting the clearance, start the engine and then disengage the clutch. Make sure that the V-belt is not being pulled by the drive pulley.

After adjustment, go to the clutch cable adjustment.

Fixed stopper**STANDARD CLEARANCE:**

B: 3.0 – 5.0 mm (0.12 – 0.20 in)

C: 6.0 – 8.0 mm (0.24 – 0.31 in)

D: 2.0 – 4.0 mm (0.08 – 0.16 in)

E: 2.0 – 4.0 mm (0.08 – 0.16 in)

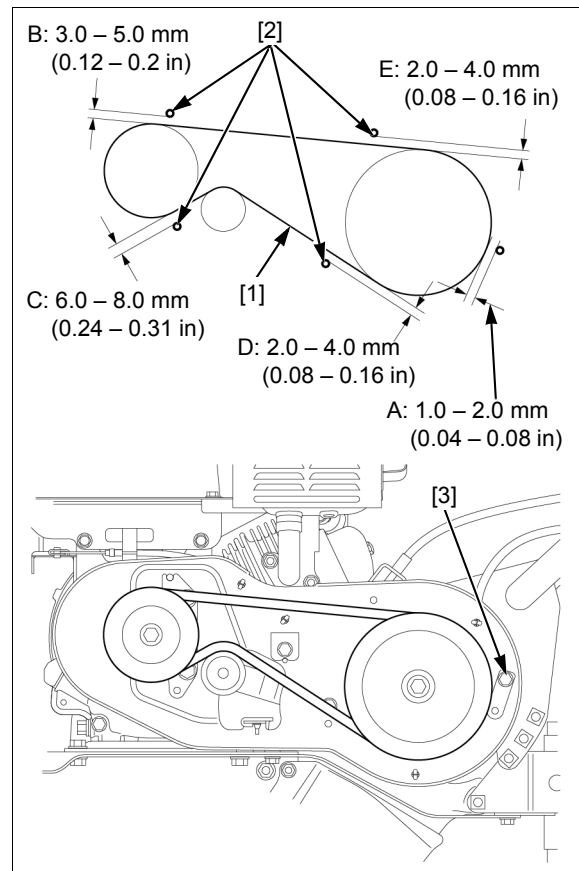

MAINTENANCE

VALVE CLEARANCE CHECK/ADJUSTMENT

NOTICE

- *Valve clearance inspection and adjustment must be performed with the engine cold.*

Disconnect the spark plug cap [1].

Remove the cylinder head cover bolt [2] and rubber mount [3] from the cylinder head cover [4].

Remove the breather tube [5] from the cylinder head cover.

Remove the cylinder head cover and packing [6].

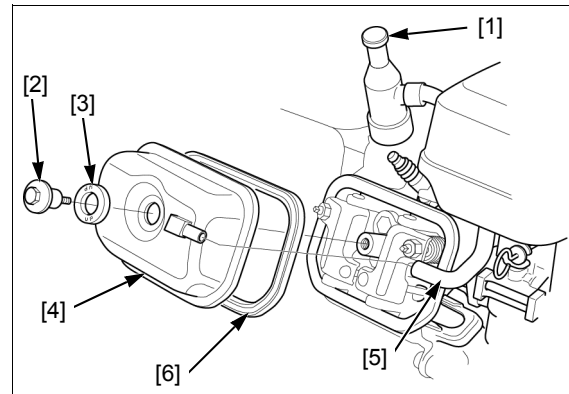

Remove the recoil starter (page 8-2).

Turn the crankshaft until the piston is at top dead center on its compression stroke (both valves fully closed) by turning the starter pulley [1].

Align the alignment mark [2] of the starter pulley and projection [3] on the fan cover.

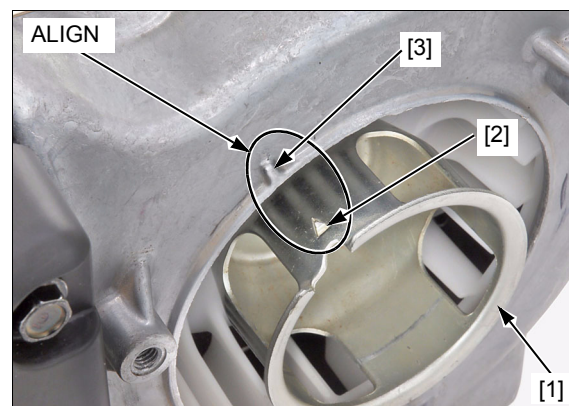

Insert a thickness gauge [1] between the tappet adjusting screw [2] and valve stem end [3] to measure the valve clearance.

VALVE CLEARANCE:

IN: 0.10 ± 0.02 mm (0.004 ± 0.001 in)

EX: 0.15 ± 0.02 mm (0.006 ± 0.001 in)

If adjustment is necessary, proceed as follows:

Hold the tappet adjusting screw and loosen the tappet adjusting nut [4].

Turn the tappet adjusting screw to obtain the specified clearance.

Hold the tappet adjusting screw and retighten the tappet adjusting nut to the specified torque.

TORQUE: 7.0 N·m (0.7 kgf·m, 5.2 lbf·ft)

Recheck the valve clearance, and if necessary, readjust the clearance.

Replace the head cover packing with a new one and install the removed parts in the reverse order of removal (page 12-3).

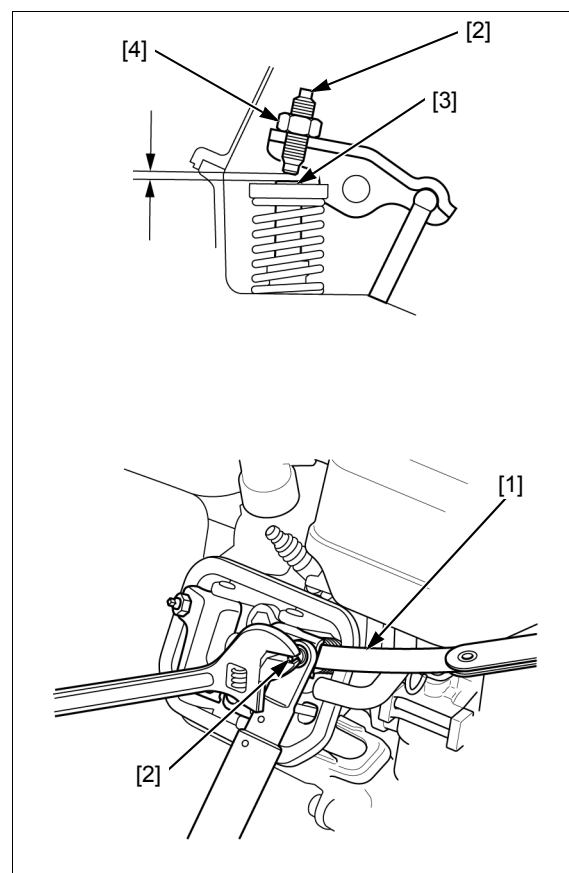

MAINTENANCE**COMBUSTION CHAMBER CLEANING**

Remove the cylinder head (page 12-3).

Clean any carbon deposits from the combustion chamber [1].

Install the cylinder head (page 12-3).

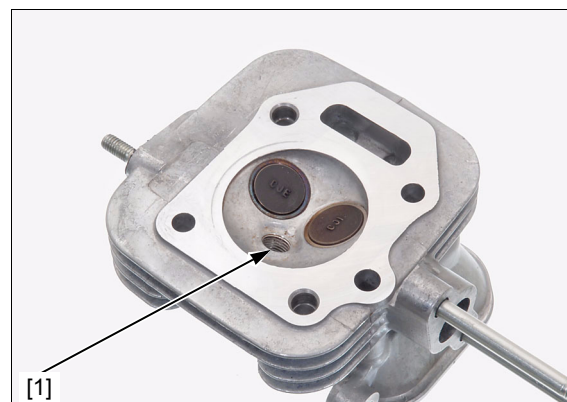
**FUEL TANK AND STRAINER CLEANING****⚠ WARNING**

Gasoline is highly flammable and explosive. You can be burned or seriously injured when handling fuel.

- Keep heat, sparks, and flame away.
- Handle fuel only outdoors.
- Wipe up spills immediately.

Remove the fuel tank (page 5-3).

Remove the fuel tank tube [1], and fuel strainer [2] from the fuel tank [3].

Clean the fuel strainer and fuel tank with non-flammable solvent, and allow it to dry thoroughly.

Check the screen of the fuel strainer for clogs or damage.

Replace if necessary.

Install the fuel strainer, and fuel tank tube to the fuel tank.

Install the fuel tank (page 5-3).

After installation, check for any signs of fuel leakage.

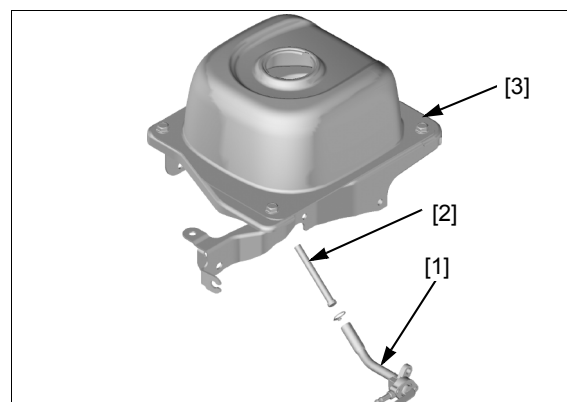
**FUEL TUBE CHECK****⚠ WARNING**

Gasoline is highly flammable and explosive. You can be burned or seriously injured when handling fuel.

- Keep heat, sparks, and flame away.
- Handle fuel only outdoors.
- Wipe up spills immediately.

Check the fuel tubes [1] for deterioration, cracks, or signs of leakage.

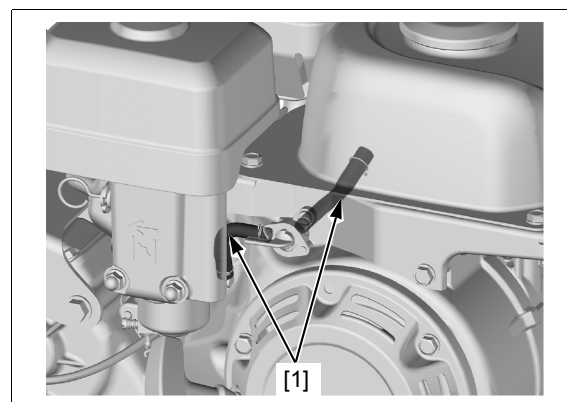



MEMO

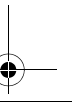
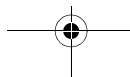
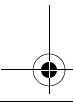
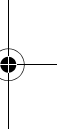
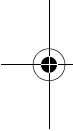

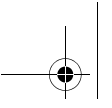

4. TROUBLESHOOTING

BEFORE TROUBLESHOOTING.....4-2

ENGINE TROUBLESHOOTING 4-3

GENERAL SYMPTOMS AND POSSIBLE
CAUSES4-2

FRAME TROUBLESHOOTING 4-3

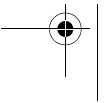
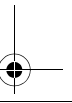
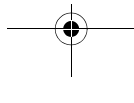
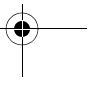
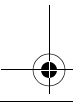
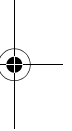
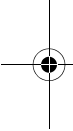

TROUBLESHOOTING

BEFORE TROUBLESHOOTING

- Check that the engine stop switch wire connector and ignition coil wire connector are connected securely.
- Check for sufficient fresh fuel in the fuel tank.

GENERAL SYMPTOMS AND POSSIBLE CAUSES

HARD STARTING

- Fuel tube or filter restricted
 - Clean (page 3-15)
- Carburetor out of adjustment
 - Disassemble and inspect (page 5-7)
- Ignition coil air gap misadjusted
 - Adjust (page 7-6)
- Ignition coil faulty
 - Inspect (page 7-6)
- Spark plug faulty
 - Inspect (page 3-9)
- Governor misadjusted
 - Adjust (page 6-2)
- Valve clearance incorrect
 - Adjust (page 3-14)

ENGINE LACKS POWER

- Spark plug faulty
 - Inspect (page 3-9)
- Governor misadjusted
 - Adjust (page 6-2)
- Valve clearance incorrect
 - Adjust (page 3-14)
- Valve seat worn or damaged
 - Inspect and correct (page 12-11)
- Cylinder, piston or piston rings worn
 - Disassemble and inspect (page 13-3)

ENGINE WILL NOT REV SUFFICIENTLY

- Carburetor out of adjustment
 - Disassemble and inspect (page 5-7)

POOR PERFORMANCE AT LOW SPEED

- Carburetor out of adjustment
 - Disassemble and inspect (page 5-7)
- Governor misadjusted
 - Adjust (page 6-2)
- Valve clearance incorrect
 - Adjust (page 3-14)

POOR PERFORMANCE AT HIGH SPEED

- Spark plug faulty
 - Inspect (page 3-9)
- Governor misadjusted
 - Adjust (page 6-2)

ENGINE TROUBLESHOOTING

HARD STARTING

1. Spark Plug Inspection

Inspect the spark plug (page 3-9).

Is the spark plug in good condition?

YES – GO TO STEP 2.

- NO** –
- Faulty spark plug
 - Incorrect spark plug gap
 - Faulty carburetor float valve and/or float (If the spark plug is wet severely)
 - Inspection (page 5-7)
 - Clogged fuel filter
 - Inspection (page 3-15)
 - Clogged fuel tube
 - Inspection (page 3-15)
 - Clogged carburetor port, nozzle
 - Inspection (page 5-7)

2. Ignition System Inspection

Check the ignition system (page 7-2).

Is the ignition system normal?

YES – GO TO STEP 3.

NO – Faulty ignition system

3. Cylinder Compression Inspection

Test the cylinder compression (page 12-5).

Is the compression normal?

- NO** –
- Carbon deposits in the combustion chamber
 - Cleaning (page 3-15)
 - Valve clearance incorrect
 - Adjustment (page 3-14)
 - Defective cylinder head gasket, valves, valve seats
 - Disassembly and inspection (page 12-4)
 - Loosen cylinder head bolts
 - Retightening (page 12-3)
 - Worn cylinder, piston, piston rings
 - Disassembly and inspection (page 13-3)
 - Worn valves
 - Inspection (page 12-5)

FRAME TROUBLESHOOTING

CLUTCH CAN NOT BE DISENGAGED

- Clutch cable misadjusted
 - Adjust (page 3-10)
- Tension arm return spring defective
 - Replace (page 15-9)
- V-belt misadjusted
 - Adjust (page 3-11)
- Tension arm binding on tension arm shaft
 - Clean and lubricate (page 15-9)

CLUTCH CAN NOT BE ENGAGED

- Clutch cable misadjusted
 - Adjust (page 3-10)
- V-belt misadjusted
 - Adjust (page 3-11)
- Tension arm binding on tension arm shaft
 - Clean and lubricate (page 15-9)

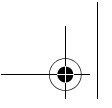

MEMO

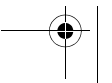
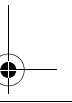
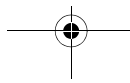
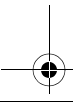
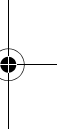
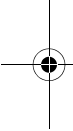

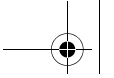

5. FUEL SYSTEM

5

TOOL	5-2	CARBURETOR BODY CLEANING	5-8
FUEL TANK REMOVAL/INSTALLATION	5-3	CARBURETOR INSPECTION	5-8
AIR CLEANER REMOVAL/ INSTALLATION	5-4	CHOKE REPLACEMENT	5-9
CARBURETOR REMOVAL/ INSTALLATION	5-5	FLOAT VALVE INSPECTION	5-9
CARBURETOR DISASSEMBLY/ ASSEMBLY	5-7	FLOAT CHAMBER INSPECTION	5-10



5-1



FUEL SYSTEM

TOOL

Float level gauge
07401-0010000

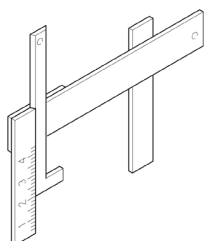

FUEL TANK REMOVAL/INSTALLATION

⚠ WARNING

Gasoline is highly flammable and explosive. You can be burned or seriously injured when handling fuel.

- Keep heat, sparks and flame away.
- Handle fuel only outdoors.
- Wipe up spills immediately.

Remove the air cleaner (page 5-4).

NOTE:

- After installation, route the fuel tube to the carburetor insulator properly (page 2-8).

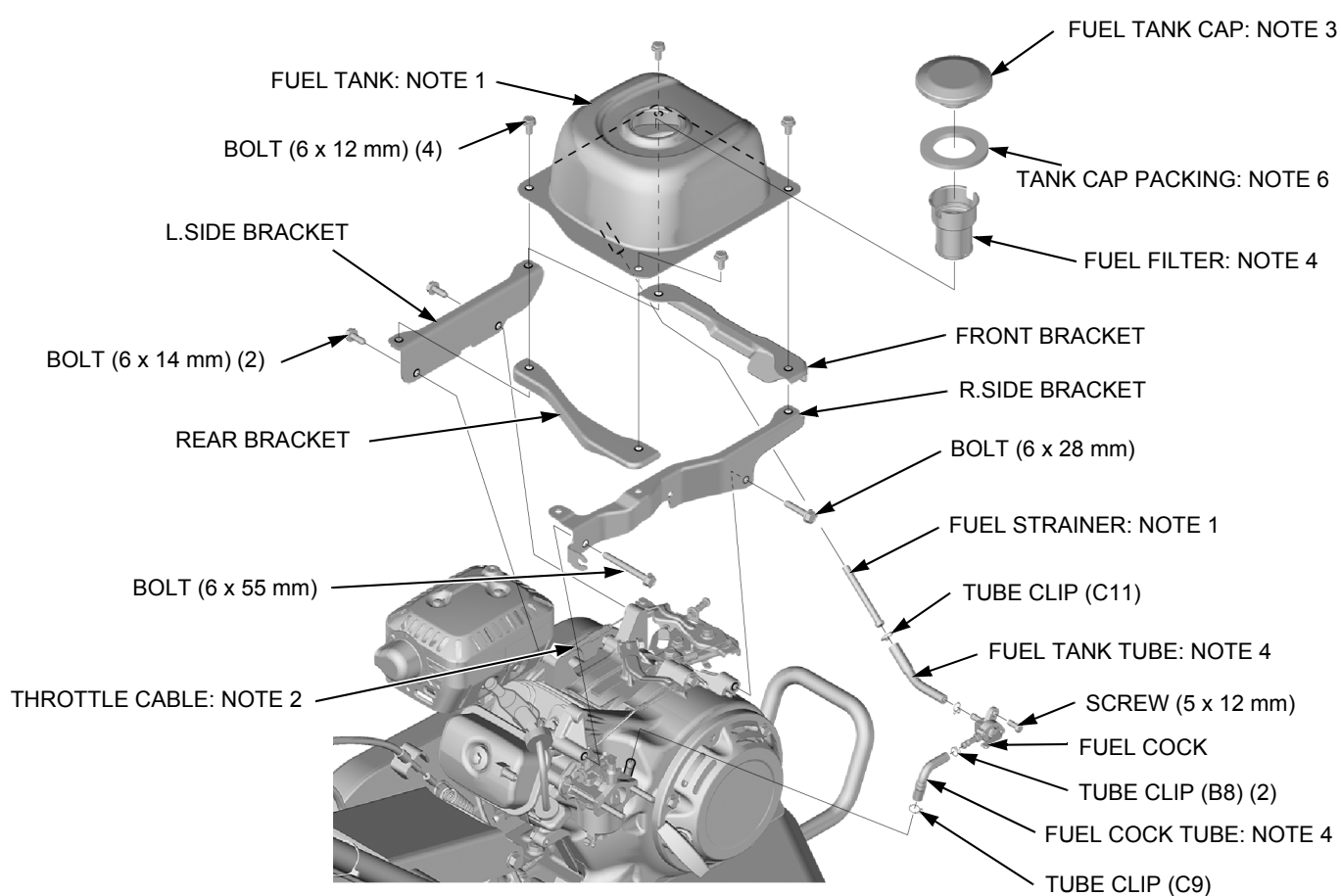

NOTE 1	FUEL TANK AND STRAINER CLEANING	page 3-15
NOTE 2	THROTTLE CABLE REMOVAL/INSTALLATION	page 14-2
NOTE 3	Before reassembly, make sure that the air vent hole is clean and unclogged. Blow with compressed air if necessary.	—
NOTE 4	Before reassembly, make sure that the strainer is clean and undamaged.	—
NOTE 5	Check for crack or deterioration before installation and replace it if necessary.	—
NOTE 6	Check the tank cap packing for wear or damage. Replace it if necessary.	—

FUEL SYSTEM

AIR CLEANER REMOVAL/INSTALLATION

NOTE:

- Before installation, route the breather tube properly (page 2-8).

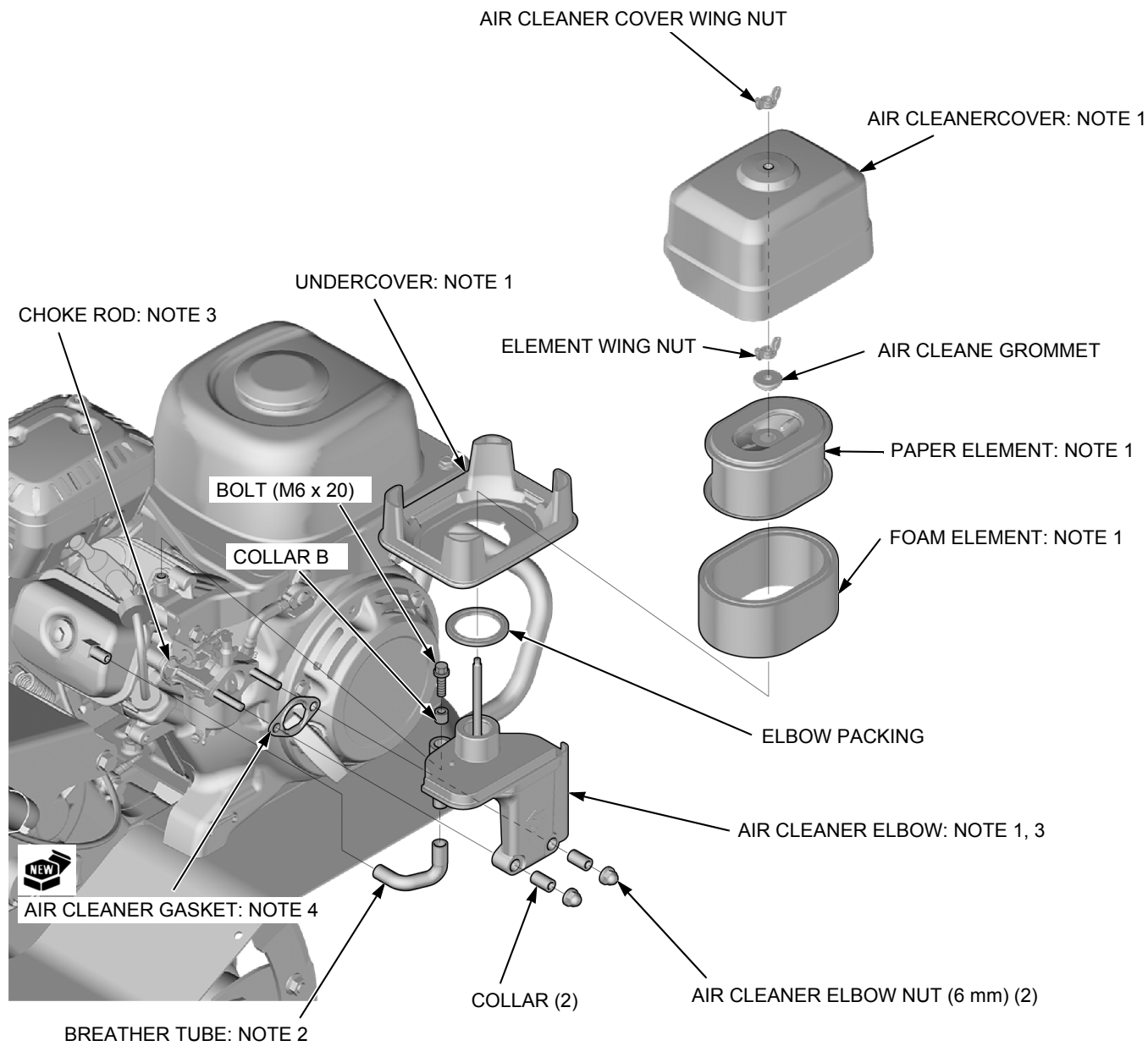

NOTE 1	AIR CLEANER CHECK/CLEANING/REPLACEMENT	page 3-5
NOTE 2	Before installation, check for cracks or deterioration.	-
NOTE 3	Note the installation direction.	-

CARBURETOR REMOVAL/INSTALLATION

⚠ WARNING

Gasoline is highly flammable and explosive. You can be burned or seriously injured when handling fuel.

- Keep heat, sparks and flame away.
- Handle fuel only outdoors.
- Wipe up spills immediately.

Remove the air cleaner (page 5-4).

Remove the fuel tank (page 5-3)

When installing, route the tubes properly (page 2-8).

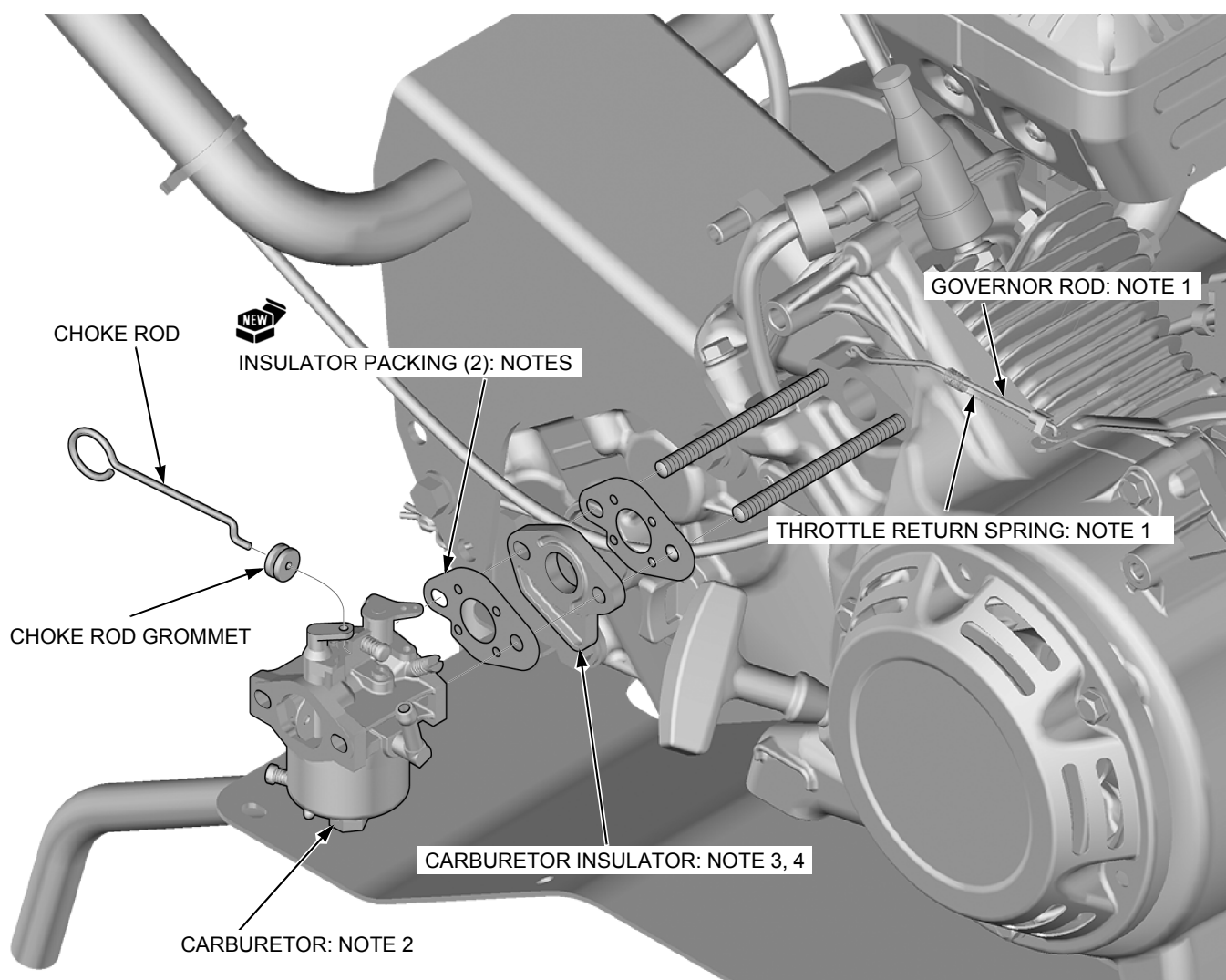

NOTE 1	GOVERNOR ROD REMOVAL/INSTALLATION	page 5-6
NOTE 2	CARBURETOR DISASSEMBLY/ASSEMBLY	page 5-7
NOTE 3	Before installation, blow the passages with compressed air.	-
NOTE 4	After installation, connect the fuel tube securely.	-
NOTE 5	Note the installation direction.	-

FUEL SYSTEM

GOVERNOR ROD REMOVAL/INSTALLATION

Pull the carburetor toward a point where the groove [1] in the throttle arm [2] lines up with the governor rod [3], and lift the rod out of its hole and unhook the throttle return spring [4].

Install the governor rod in the reverse order of removal.

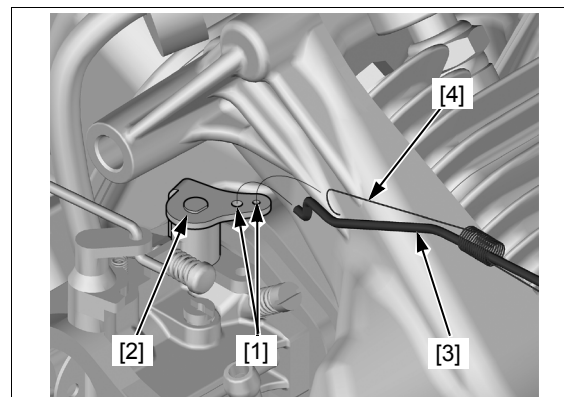

CARBURETOR DISASSEMBLY/ASSEMBLY

⚠ WARNING

Gasoline is highly flammable and explosive. You can be burned or seriously injured when handling fuel.

- Keep heat, sparks, and flame away.
- Handle fuel only outdoors.
- Wipe up spills immediately.

⚠ CAUTION

To prevent serious eye injury, always wear safety goggles or other eye protection when using compressed air.

Remove the carburetor (page 5-5).

Before disassembly, clean the outside of the carburetor.

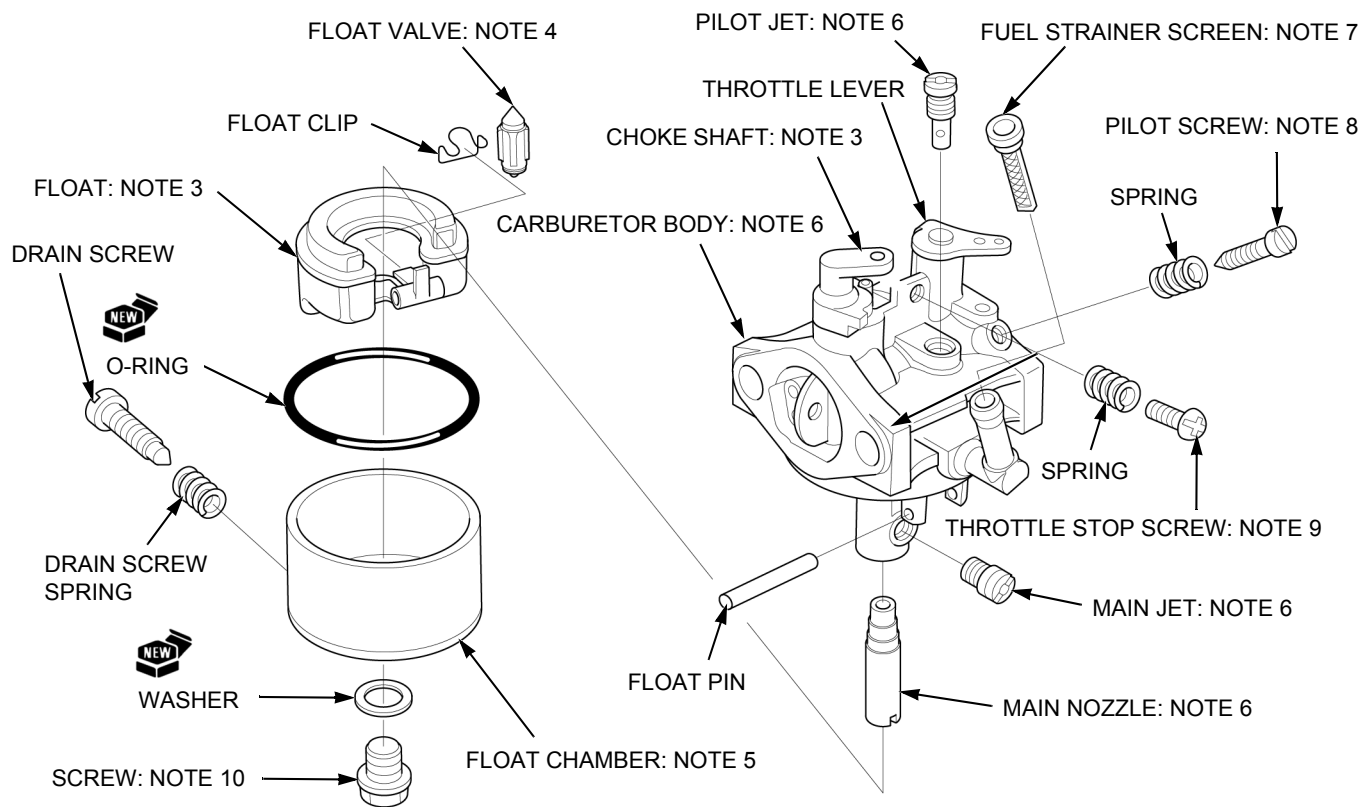

NOTE 1	CARBURETOR BODY CLEANING	page 5-8
NOTE 2	CABRURETOR INSPECTION	page 5-8
NOTE 3	CHOKE REPLACEMENT	page 5-9
NOTE 4	FLOAT VALVE INSPECTION	page 5-9
NOTE 5	FLOAT CHAMBER INSTALLATION	page 5-10
NOTE 6	Before installation, clean thoroughly with low pressure compressed air.	-
NOTE 7	Before installation, clean the screen and check for damage.	-
NOTE 8	Turn the pilot screw in until it is lightly seated, and then turn the screw out the required number of turns. PILOT SCREW Opening: 1 3/8 turn out	-
NOTE 9	Turn the throttle stop screw in until it is touched to throttle lever (closed position), and then turn the clockwise two turns.	-
NOTE 10	After assembly, check for any sign of fuel leakage.	-

FUEL SYSTEM

CARBURETOR BODY CLEANING

⚠ CAUTION

To prevent serious eye injury, always wear safety goggles or other eye protection when using compressed air.

NOTICE

- Some commercially available chemical cleaners are very caustic. These cleaners may damage plastic parts such as the O-ring, the float, and the float valve of the carburetor. Check the container for instructions. If you are in doubt, do not use these products to clean a Honda carburetor.
- High air pressure may damage the carburetor. Use low air pressure (0.2 MPa (30 psi) or less) when cleaning passages and ports.

Clean the carburetor body [1] with high flash point solvent.

Clean thoroughly the following passages and ports with low pressure compressed air.

- Pilot screw hole [2]
- Pilot jet hole [3]
- Pilot air jet [4]
- Main air jet [5]
- Bypass hole [6]
- Main nozzle holder [7]
- External vent port [8]

INTAKE SIDE:

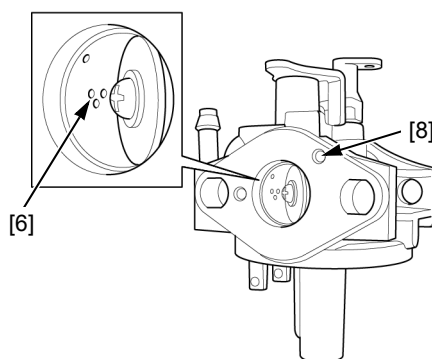
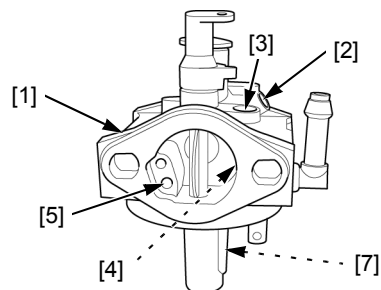

ENGINE SIDE:

CARBURETOR INSPECTION

FLOAT LEVEL HEIGHT

Place the carburetor in the position as shown, and measure the distance between the float top [1] and carburetor body [2] when the float just contacts the valve seat [3].

STANDARD FLOAT HEIGHT: 20.2 mm (0.80 in)

If the height is outside the specification, replace the float and float valve and recheck the height.

Check for smooth movement after installation.

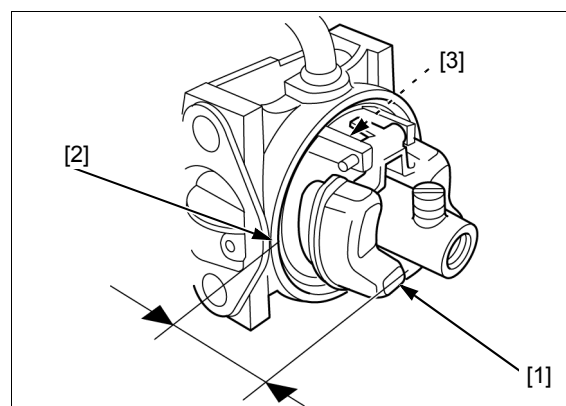

FUEL SYSTEM

CHOKE REPLACEMENT

Remove the carburetor (page 5-5).

Pull out the choke valve plate [1].

Remove the choke shaft [2] and install a new choke shaft.

Insert a new choke valve plate into the slit [3] of the choke shaft.

Be sure the choke shaft is in the position between the projections [4] of the choke valve plate.

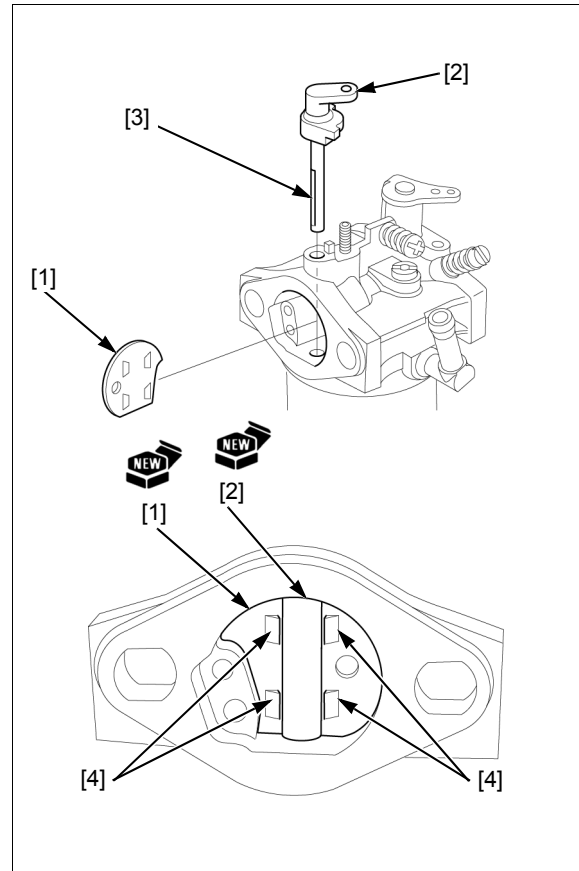

FLOAT VALVE INSPECTION

Before installation, check for worn float valve seat [1], float valve [2].

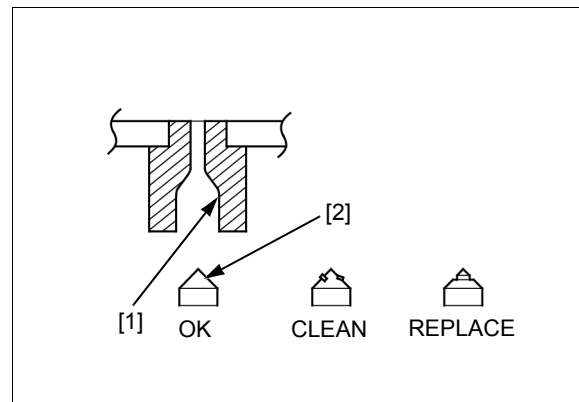

FUEL SYSTEM

FLOAT CHAMBER INSPECTION

Install the float chamber to the carburetor body at an angle as shown.

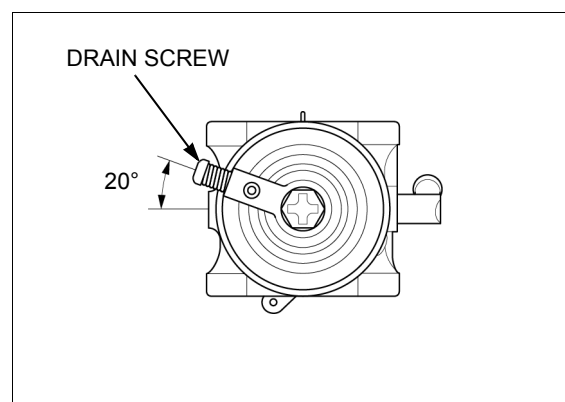

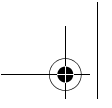

6. GOVERNOR SYSTEM

6

GOVERNOR ARM/CONTROL BASE
REMOVAL/INSTALLATION6-2

GOVERNOR DISASSEMBLY/
ASSEMBLY6-4

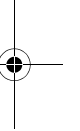
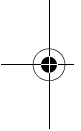

6-1

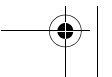
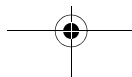

GOVERNOR SYSTEM

GOVERNOR ARM/CONTROL BASE REMOVAL/INSTALLATION

Remove the fuel tank (page 5-3).

Remove the throttle cable (page 14-2).

After installation, adjust the engine speed (page 3-10).

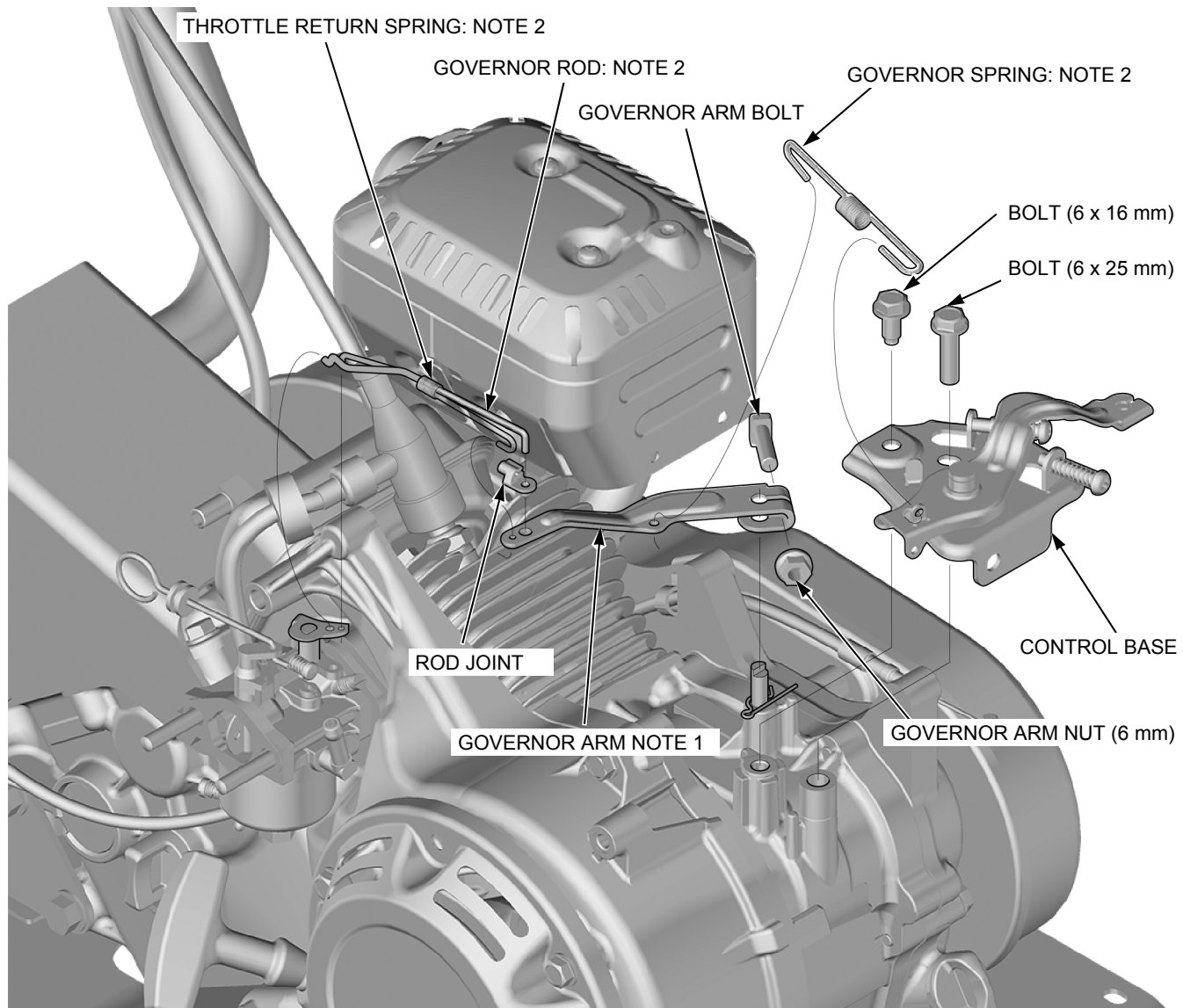

NOTE 1	GOVERNOR ARM INSTALLATION	page 6-3
NOTE 2	GOVERNOR ROD/THROTTLE RETURN SPRING REMOVAL/INSTALLATION	page 5-6
NOTE 3	Install it with the longer end side toward the governor arm.	-

GOVERNOR SYSTEM

GOVERNOR ARM INSTALLATION

The clearance must be ensured between the governor arm bolt head and the lock pin on the governor shaft, or interfering them could cause incomplete alignment

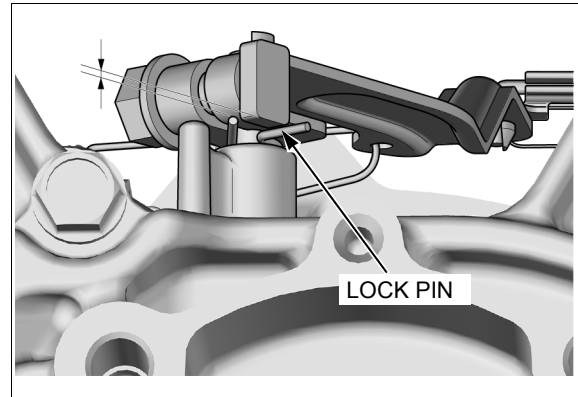

GOVERNOR ARM ALIGNMENT

Install the air cleaner gasket [1] and the air cleaner elbow [2], then tighten the nuts [3].

Loosen the nut (6 mm) [4] of the governor arm.

Turn the governor arm [5] counterclockwise to fully open the carburetor throttle valve [6].

Insert 1mm shim [7] between throttle arm [8] and carburetor body [9].

Rotate the governor arm shaft [10] as far as it will go in the same direction where the governor arm moved to open the throttle valve.

Make sure the carburetor throttle valve is fully open. Tighten torque shall be 5 N·m (0.5 kgf·m, 3.7 lbf·ft) at minimum and 0.5 mm (0.02 in) minimum for the clearance should be needed.

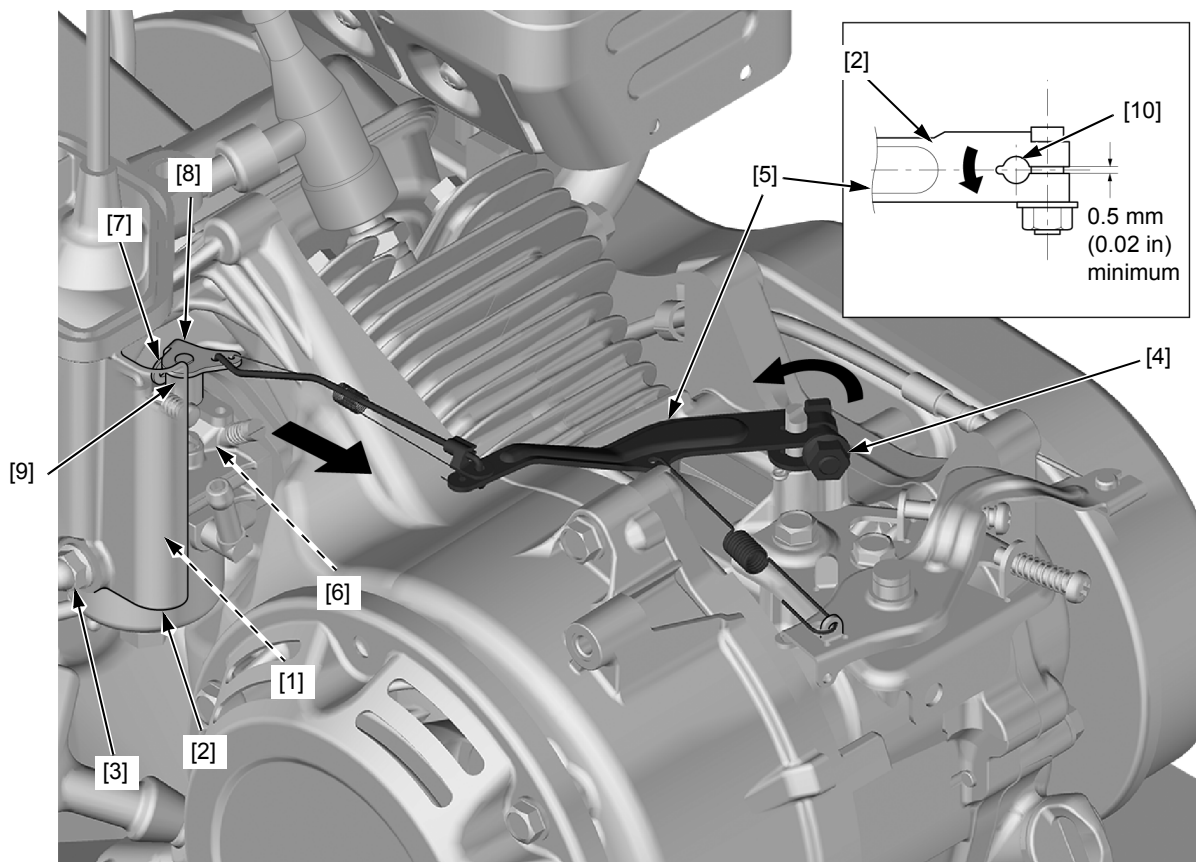

GOVERNOR SYSTEM

GOVERNOR DISASSEMBLY/ASSEMBLY

Remove the crankcase cover (page 13-3).

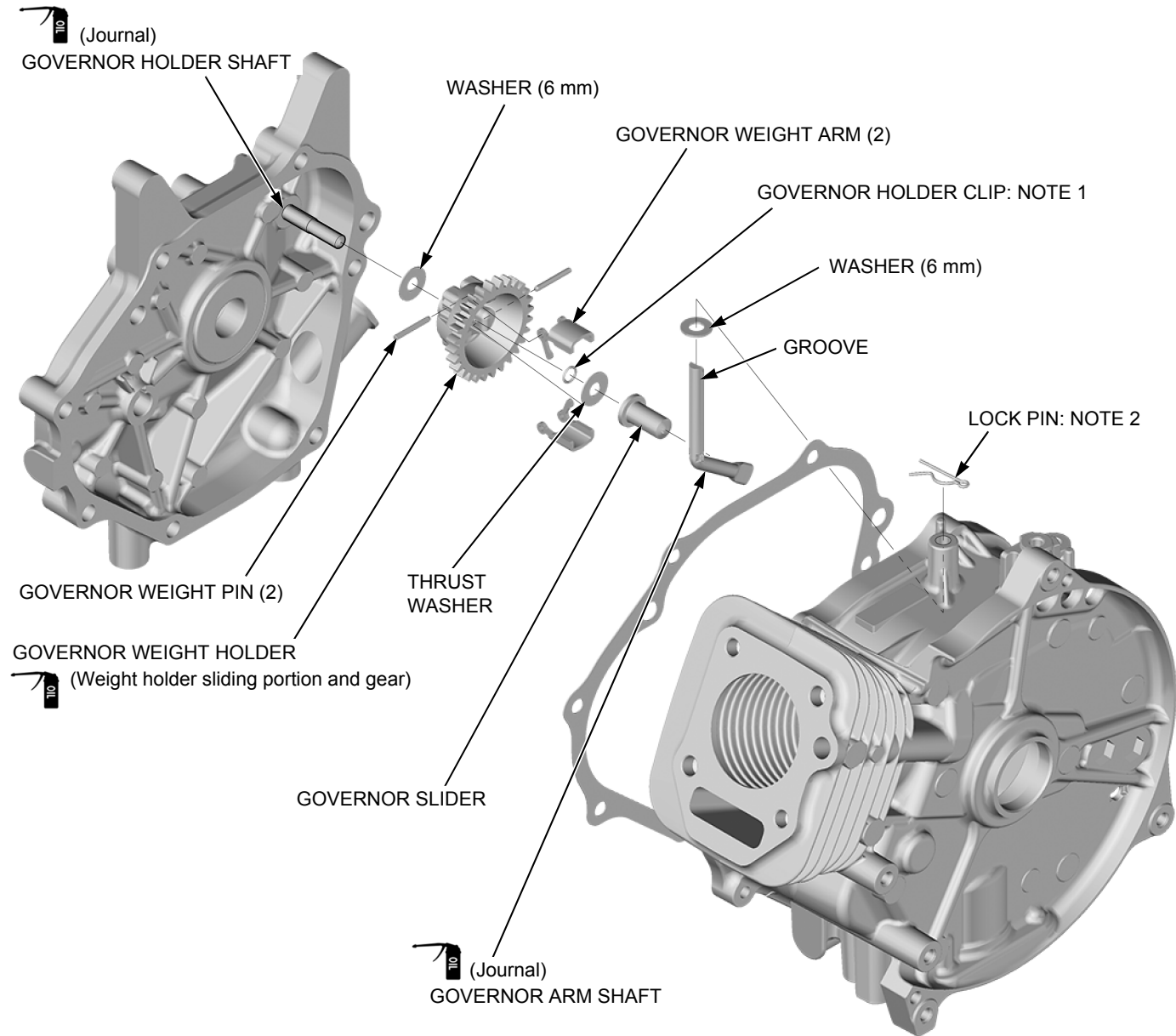

NOTE 1	GOVERNOR HOLDER CLIP INSTALLATION	page 6-5
NOTE 2	Install it firmly into the groove of the governor arm shaft.	-

GOVERNOR SYSTEM

GOVERNOR HOLDER CLIP INSTALLATION

Set the governor holder clip [1] as shown.

Pull up the governor [2] and install the thrust washer [3] and governor slider [4] through the gap between the governor weight arms [5].

Push the governor slider to press the clip into the groove [6].

Check that they are moved.

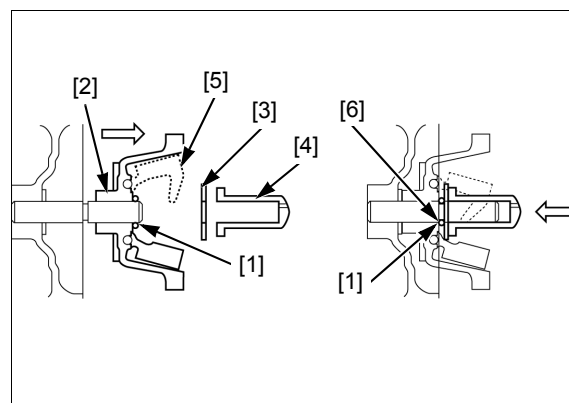

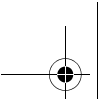

MEMO

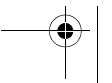
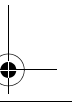
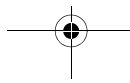
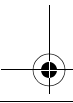
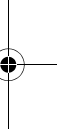
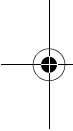

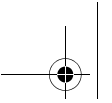

7. IGNITION SYSTEM

BEFORE TROUBLESHOOTING.....7-2	IGNITION COIL AIR GAP CHECK/ ADJUSTMENT 7-6	7
IGNITION SYSTEM TROUBLESHOOTING.....7-2	IGNITION COIL INSPECTION 7-6	
IGNITION COIL REMOVAL/ INSTALLATION7-3	SPARK PLUG CAP INSPECTION..... 7-7	
FLYWHEEL REMOVAL/INSTALLATION7-4	SPARK TEST 7-7	
	ENGINE STOP SWITCH REMOVAL/ INSTALLATION 7-8	

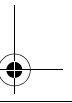
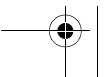
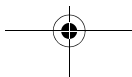
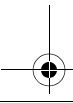
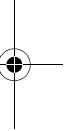
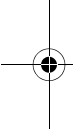

IGNITION SYSTEM

BEFORE TROUBLESHOOTING

- Check that the engine stop switch wire connector and ignition coil wire connector are connected securely.
- Check that the engine stop switch is in "ON" position.

IGNITION SYSTEM TROUBLESHOOTING

HARD STARTING

1. Spark Plug Inspection

Inspect the spark plug (page 3-9).

Is the spark plug normal?

YES – GO TO STEP 2.

NO – • Faulty spark plug
• Incorrect spark plug gap

2. Spark Test

Clean the spark plug and adjust the spark plug gap (page 3-9)
Perform the spark test (page 7-7).

Is there weak or no spark?

YES – • Faulty spark plug
• Incorrect spark plug gap

NO – GO TO STEP 3.

3. Spark Test

Perform the spark test again with a new spark plug (page 7-7).

Is there weak or no spark?

YES – Faulty spark plug

NO – GO TO STEP 4.

4. Spark Plug Cap Inspection

Inspect the spark plug cap (page 7-7).

Is the spark plug cap normal?

YES – GO TO STEP 5.

NO – Faulty spark plug cap

5. Engine stop switch Inspection

Inspect the engine stop switch (page 7-8).

Is the engine stop switch normal?

YES – GO TO STEP 6.

NO – Faulty engine stop switch

6. Ignition Coil Air Gap Inspection

Inspect the ignition coil air gap (page 7-6).

Is the ignition coil air gap normal?

YES – GO TO STEP 7.

NO – Ignition coil air gap misadjusted

7. Ignition Coil Inspection

Inspect the ignition coil (page 7-6).

Is the ignition coil normal?

NO – Ignition coil defective

IGNITION SYSTEM

IGNITION COIL REMOVAL/INSTALLATION

Remove the following:

- Engine (page 10-2)
- Air cleaner (page 5-4)
- Fuel tank (page 5-3)
- Carburetor (page 5-5)

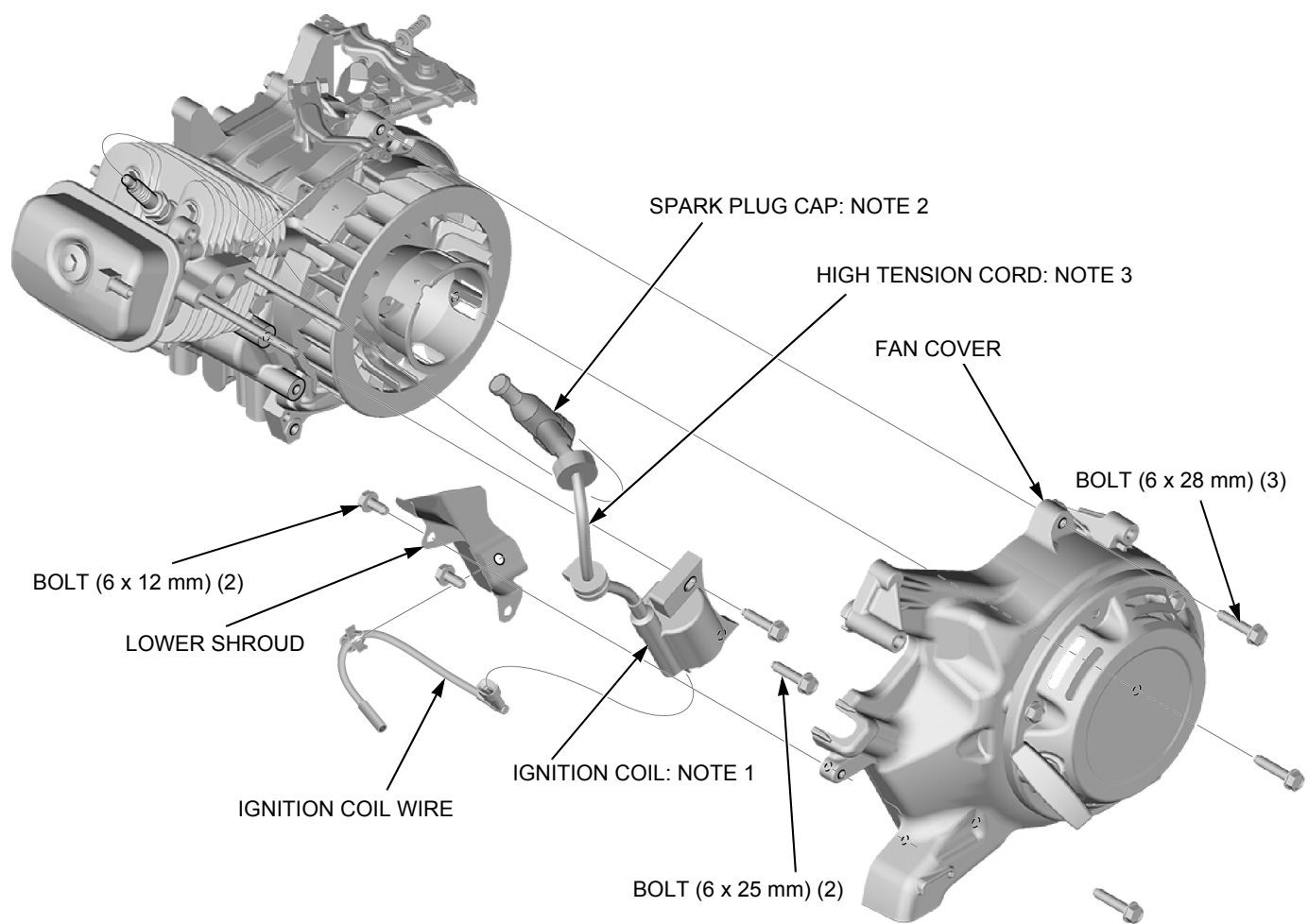

NOTE 1	IGNITION COIL INSPECTION	page 7-6
NOTE 2	SPARK PLUG CAP INSPECTION	page 7-7
NOTE 3	Check for cracked or damage insulation and replace the ignition coil if necessary.	-

IGNITION SYSTEM

FLYWHEEL REMOVAL/INSTALLATION

NOTICE

- When disassembling and reassembling, take care not to damage the fan blade.

Remove the ignition coil (page 7-3).

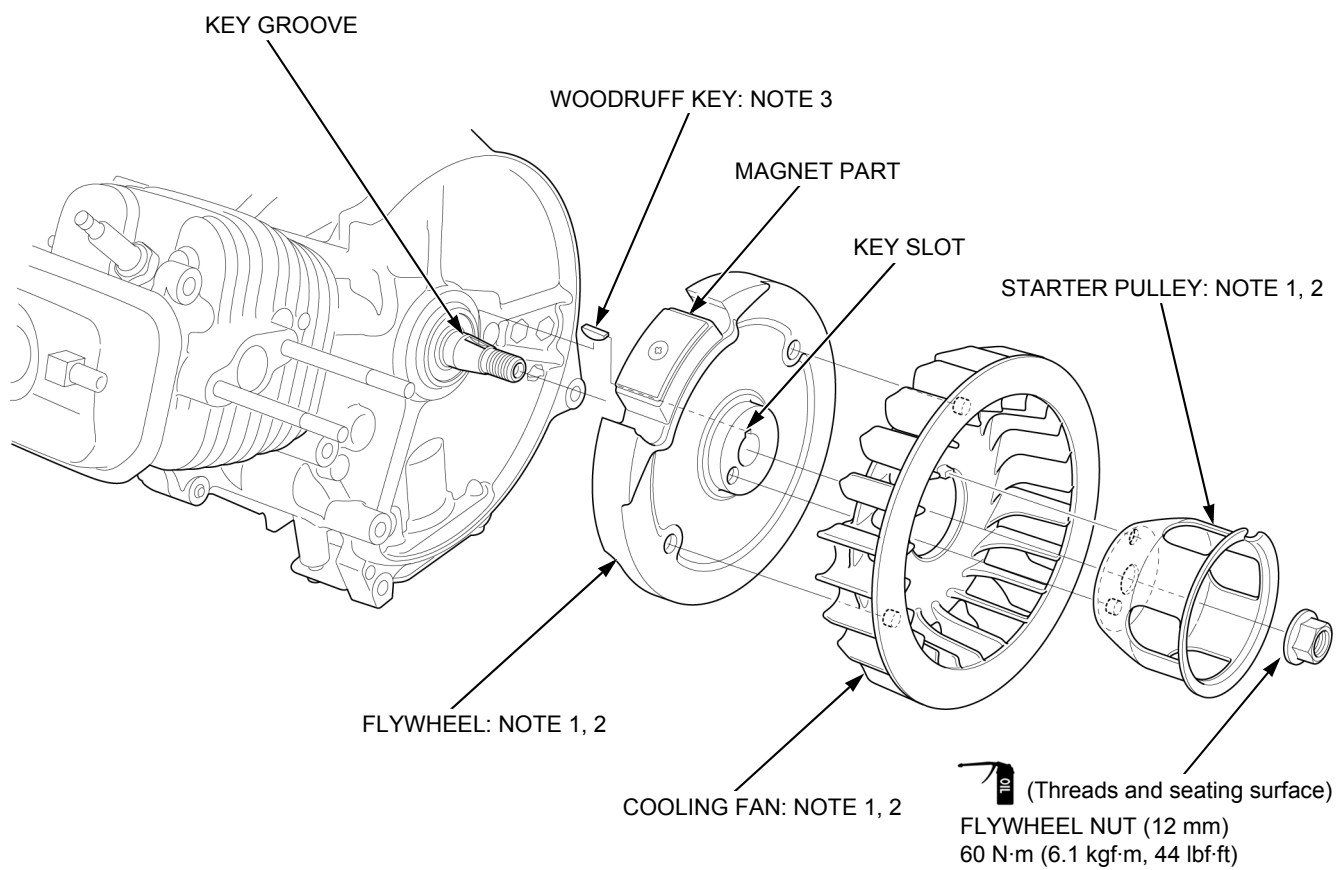

NOTE 1	FLYWHEEL REMOVAL	page 7-4
NOTE 2	FLYWHEEL INSTALLATION	page 7-5
NOTE 3	After installing the flywheel, check to be sure that the woodruff key is still in its slot on the crankshaft.	-

FLYWHEEL REMOVAL

Hold the flywheel [1] with a commercially available strap wrench [2] and remove the flywheel nut (12 mm) [3].

NOTICE

- Take care not to damage the cooling fan with the strap wrench.

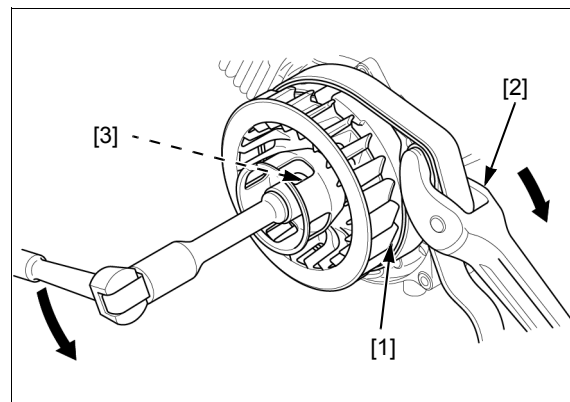

IGNITION SYSTEM

Remove the flywheel [1] with a commercially available flywheel puller [2].

NOTICE

- Do not hit the flywheel with a hammer.
- Avoid the magnet section when attaching the flywheel puller.

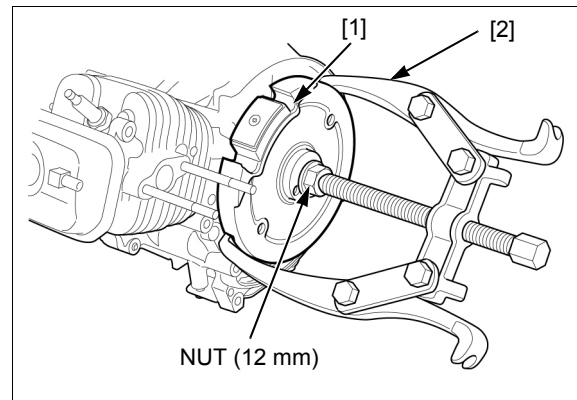

FLYWHEEL INSTALLATION

Clean the tapered parts [1] of dirt, oil, grease, and other foreign material before installation.

Be sure there are no metal parts or other foreign material on the magnet part [2] of the flywheel.

Set the woodruff key [3] in the key groove [4] of the crankshaft securely.

Install the flywheel [5] by aligning the key slot [6] with woodruff key on the crankshaft.

NOTICE

- The flywheel may push the woodruff key out of its slot; check after installation.

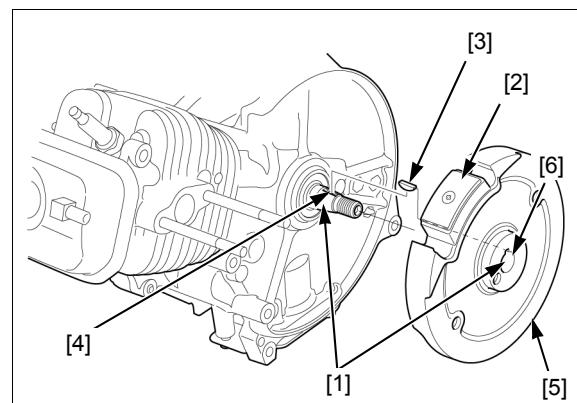

Attach the cooling fan [1] to the flywheel [2] by aligning the four projections of the cooling fan with the holes of the flywheel.

Attach the starter pulley [3] by aligning the hole of the pulley with the projection at the center of the cooling fan.

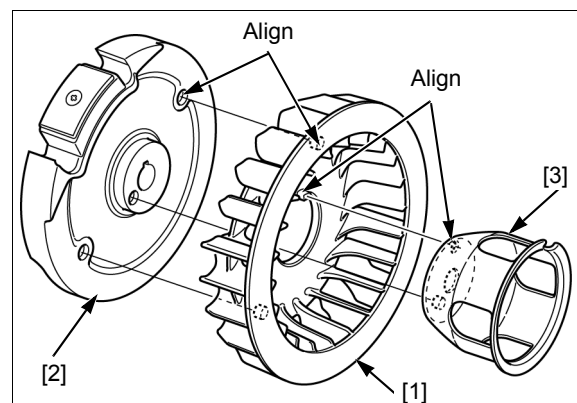

Apply engine oil to the threads and seating surface of the flywheel nut (12 mm) [1], and loosely tighten the nut.

Hold the flywheel [2] with a commercially available strap wrench [3], and tighten the nut (12 mm) to the specified torque.

TORQUE: 60 N·m (6.1 kgf·m, 44 lbf·ft)

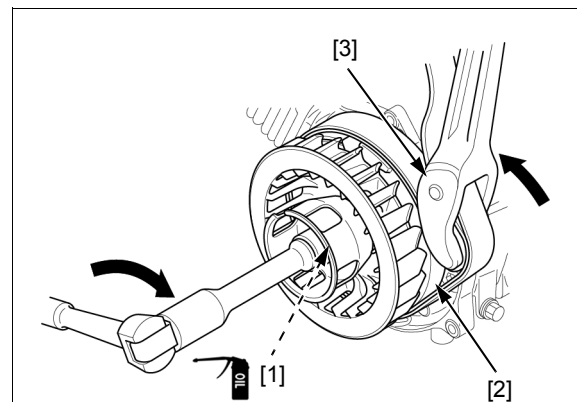

IGNITION SYSTEM

IGNITION COIL AIR GAP CHECK/ADJUSTMENT

Remove the fan cover (page 7-3).

Insert the proper thickness gauge between the ignition coil [1] and the flywheel [2].

NOTICE

- Keep the magnet part [3] of the flywheel away from the measured area when adjusting.
- Adjust the ignition coil air gap equally on both sides.

IGNITION COIL AIR GAP:

0.2 – 0.6 mm (0.01 – 0.02 in)

If measured clearance is out of specification, adjust the air gap.

Loosen the two bolts [4].

Both gaps should be adjusted simultaneously.

Insert the proper thickness gauge between the ignition coil and flywheel.

Push the ignition coil firmly against the flywheel and tighten the ignition coil bolts securely.

Remove the thickness gauge.

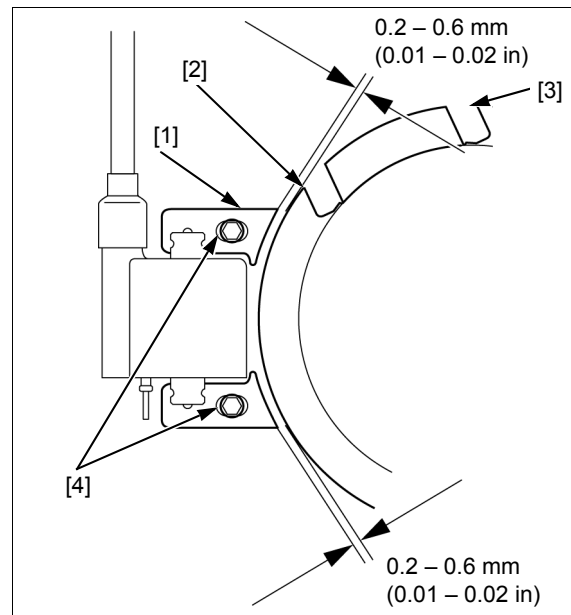

IGNITION COIL INSPECTION

PRIMARY SIDE

Measure the resistance of the primary coil by attaching an ohmmeter probe to the ignition coil wire terminal and the other to the iron core.

Use a recommended analog multi-tester.

- SP-15D (SANWA) or equivalent
- SP-18D (SANWA) or equivalent
- TH-5H (KOWA) or equivalent

RESISTANCE: 0.8 – 1.2 Ω

If the measured resistance is out of specification, replace the ignition coil (page 7-3).

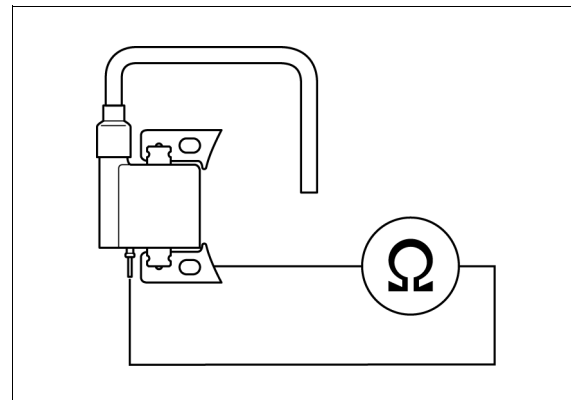

SECONDARY SIDE

Measure the resistance of the secondary coil by attaching an ohmmeter probe to the high tension cord and the other to the iron core.

Use a recommended analog multi-tester.

- SP-15D (SANWA) or equivalent
- SP-18D (SANWA) or equivalent
- TH-5H (KOWA) or equivalent

RESISTANCE: 5.6 – 11.8 k Ω

If the measured resistance is out of specification, replace the ignition coil (page 7-3).

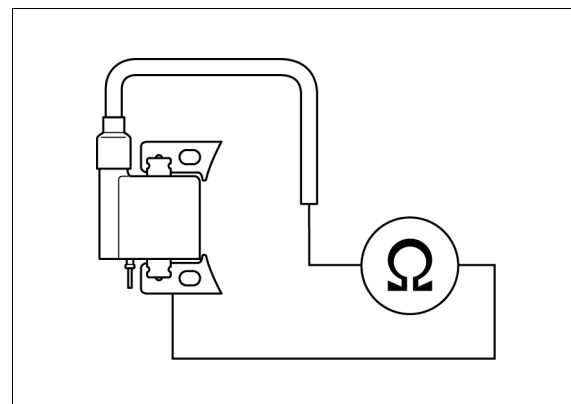

IGNITION SYSTEM

SPARK PLUG CAP INSPECTION

Check the continuity between the terminal in the spark plug cap and high tension cord terminal.

There should be continuity.

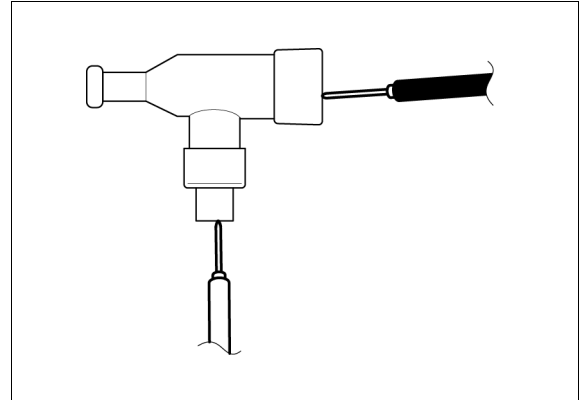

SPARK TEST

⚠ CAUTION

Never hold the high-tension cord with wet hands while performing this test.

Check for the following before conducting the spark test.

- Faulty spark plug
- Loose spark plug cap
- Water in the spark plug cap (leaking ignition coil secondary voltage)

Close the fuel valve.

Disconnect the spark plug cap [1] from the spark plug [2].

Connect a known-good spark plug [3] to the spark plug cap and ground the spark plug to the cylinder head cover bolt.

Turn the engine stop switch to the ON position.

Crank the engine by pulling the recoil starter and check whether sparks jump across the electrodes.

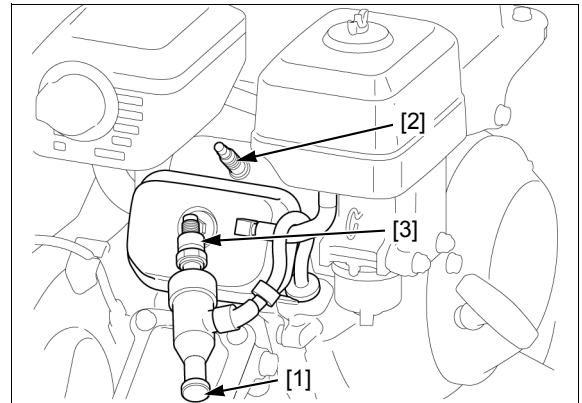

IGNITION SYSTEM

ENGINE STOP SWITCH REMOVAL/INSTALLATION

NOTE:

- Before installation, route the wire harness properly (page 2-7).

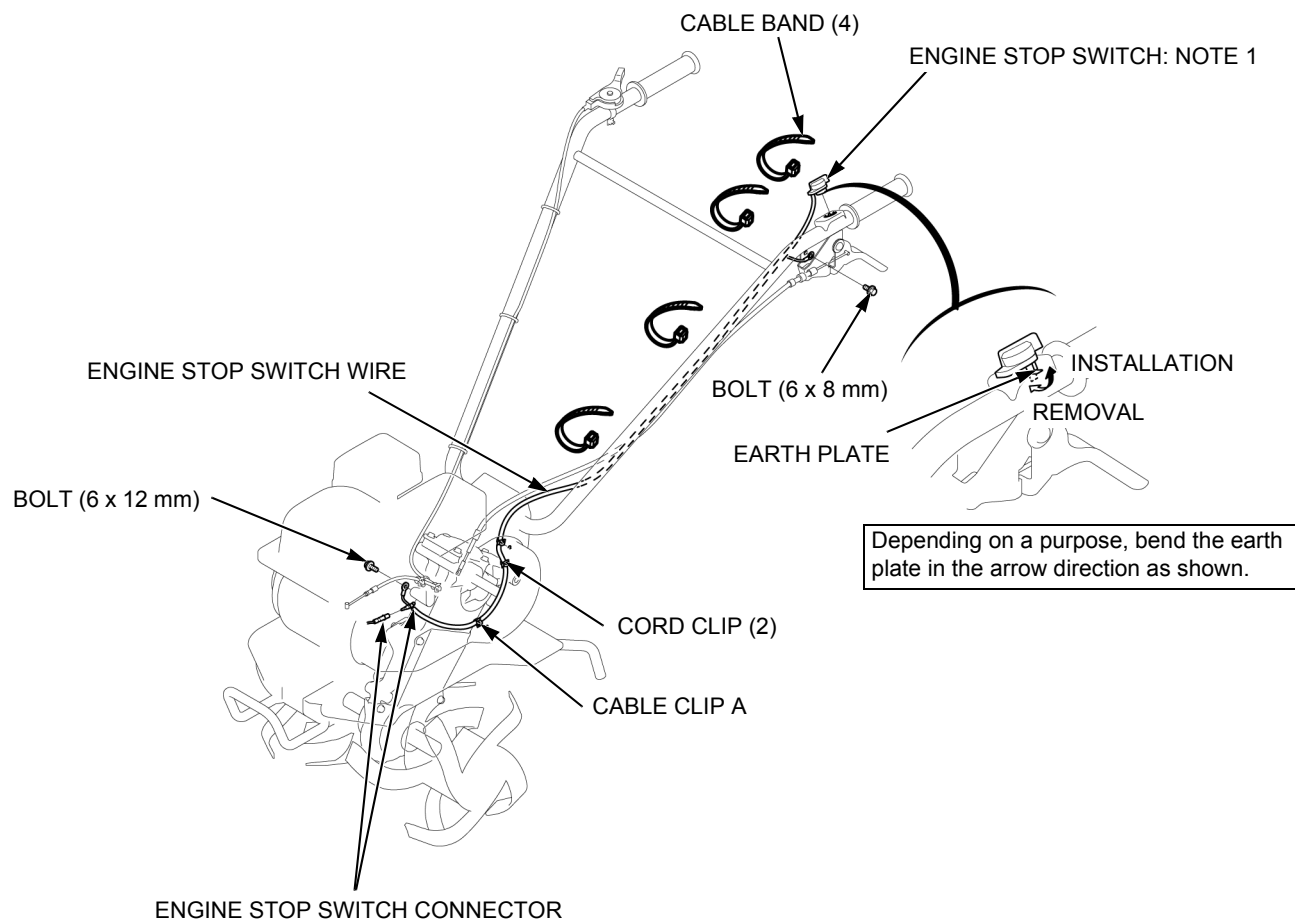

NOTE 1	ENGINE STOP SWITCH INSPECTION	page 7-8
--------	-------------------------------	----------

ENGINE STOP SWITCH INSPECTION

Check for continuity between the engine stop switch wire connector [1] and earth plate [2] in each switch position.

Switch position	Continuity
ON	No Continuity
OFF	Continuity

Make sure that there is continuity between the ground terminals [3].

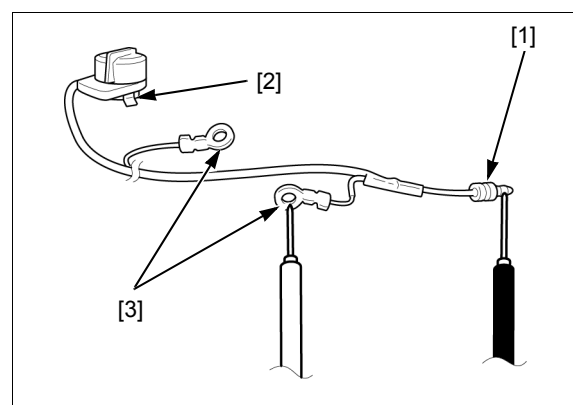

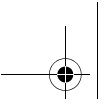

8. STARTING SYSTEM

RECOIL STARTER REMOVAL/
INSTALLATION8-2

RECOIL STARTER DISASSEMBLY/
ASSEMBLY8-3

RECOIL STARTER INSPECTION8-6

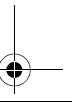
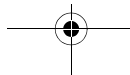
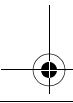
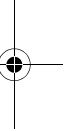
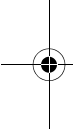

STARTING SYSTEM

RECOIL STARTER REMOVAL/INSTALLATION

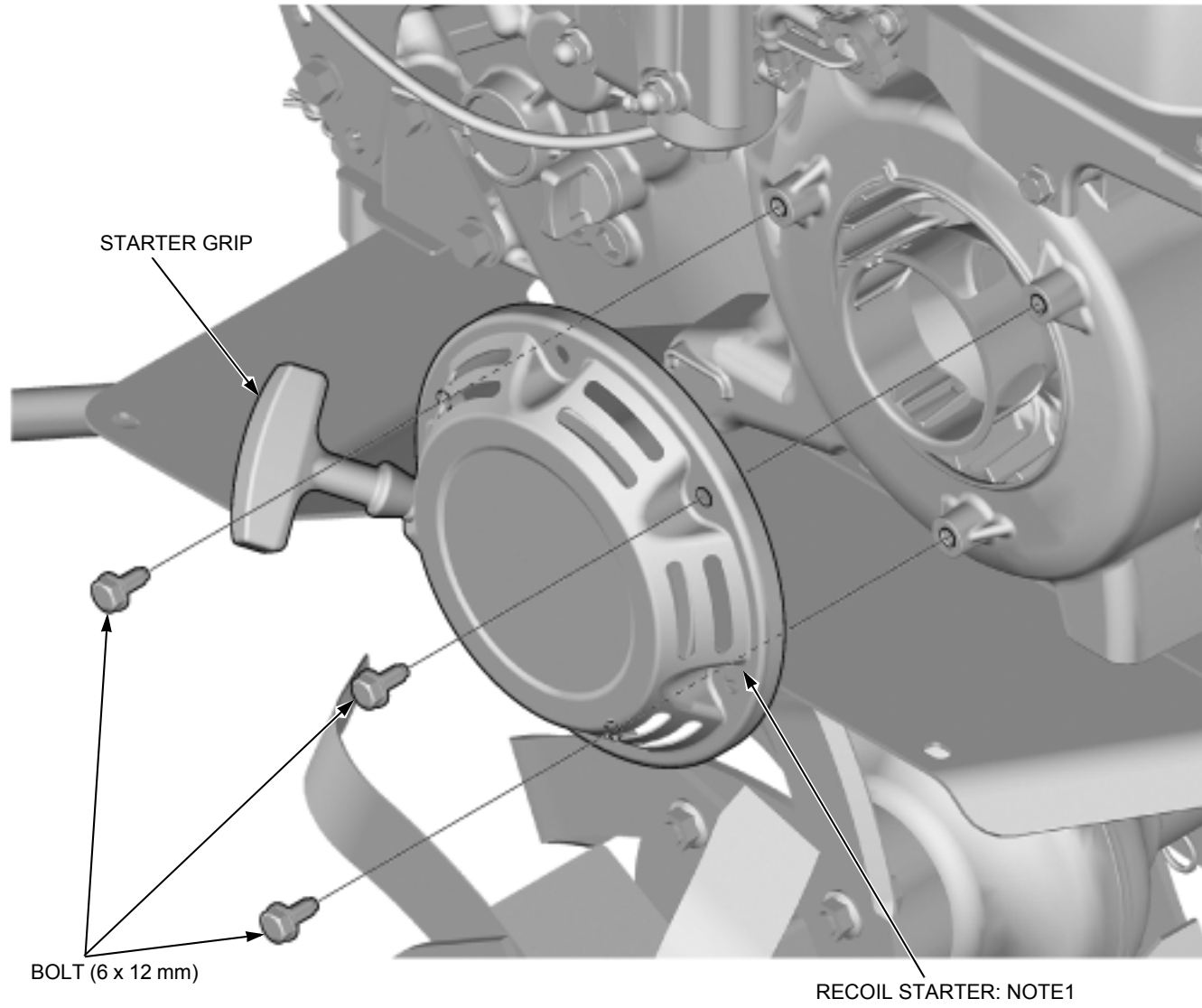

NOTE 1	Before installation, remove dirt and debris.	-
--------	--	---

STARTING SYSTEM

RECOIL STARTER DISASSEMBLY/ASSEMBLY

CAUTION

- Wear gloves and eye protection.
- During disassembly, take care not to allow the return spring to come out from the spring cover.

Remove the recoil starter (page 8-2).

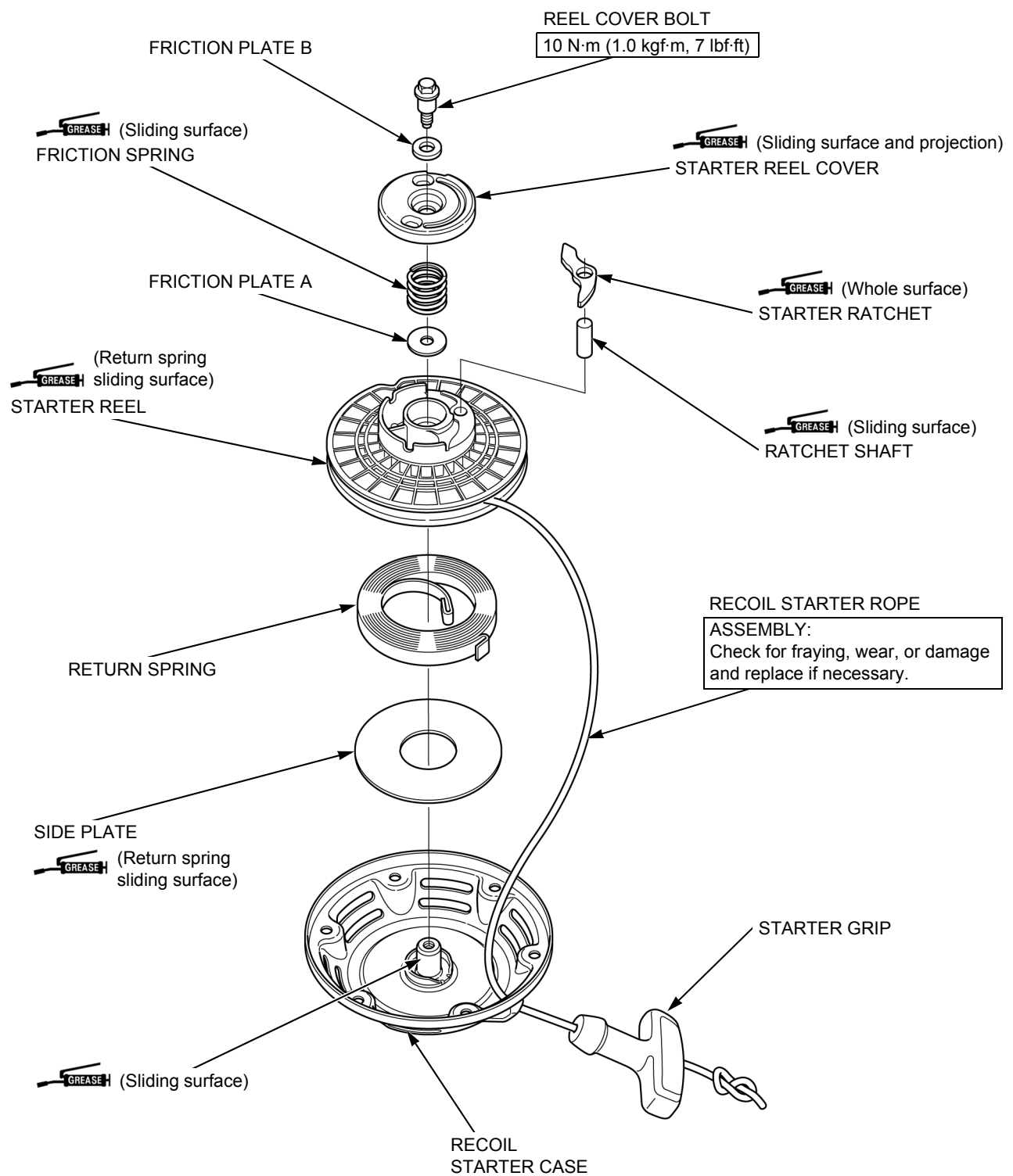

STARTING SYSTEM

RECOIL STARTER ASSEMBLY

Pass the recoil starter rope [1] through the hole [2] on the starter reel [3] and make a figure eight knot [4] at the end of the rope.
Wind the recoil starter rope onto the reel as shown.

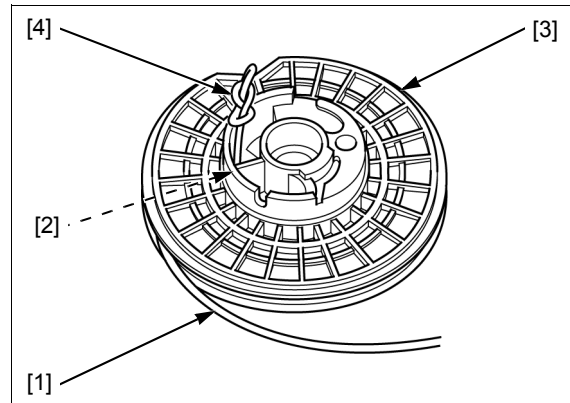

Hook the recoil starter rope [1] into the notch [2] on the recoil starter reel [3].

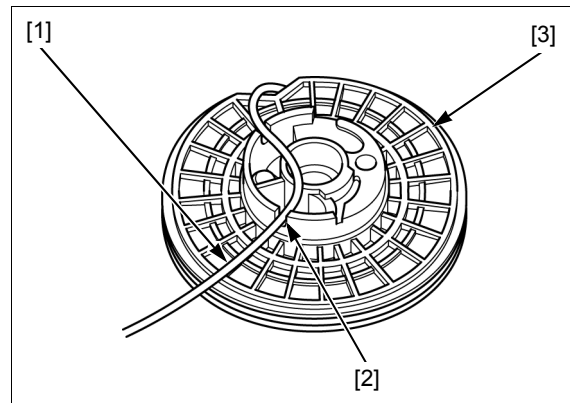

Apply grease to the return spring sliding surface of the starter reel [1].

Hook the outer hook [2] of the return spring [3] to the groove [4] of the starter reel and then install the return spring by winding it.

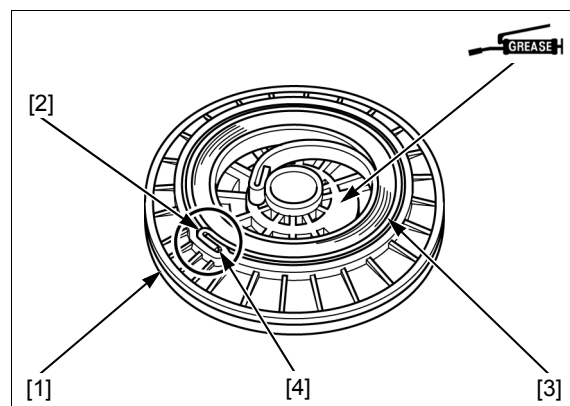

Install the side plate [1] to the recoil starter case [2].

Apply grease to the inside of the side plate and boss of the starter case.

Insert the reel [3] into the recoil starter case by aligning the return spring inner end hook [4] with the boss [5] on the recoil starter case.

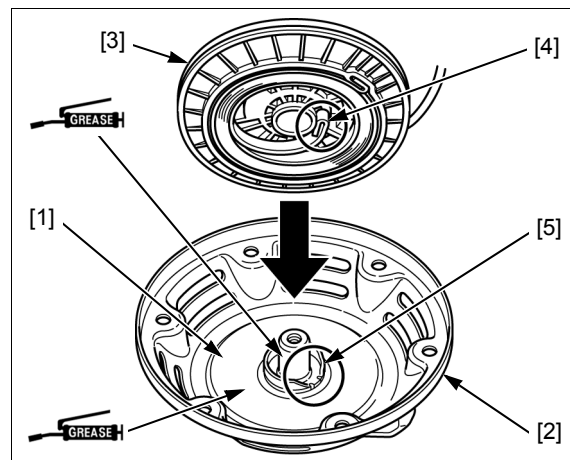

STARTING SYSTEM

Apply grease to the sliding surface of the ratchet shaft [1], starter ratchet [2], friction spring [3] and starter reel cover [4].

Install the ratchet shaft, starter ratchet, friction plate A [5], friction spring and starter reel cover to the starter reel [6] as shown.

Set the friction plate B [7] and reel cover bolt [8] in the starter reel cover.

Hold the starter reel cover and tighten the reel cover bolt to the specified torque.

TORQUE: 10 N·m (1.0 kgf·m, 7 lbf·ft)

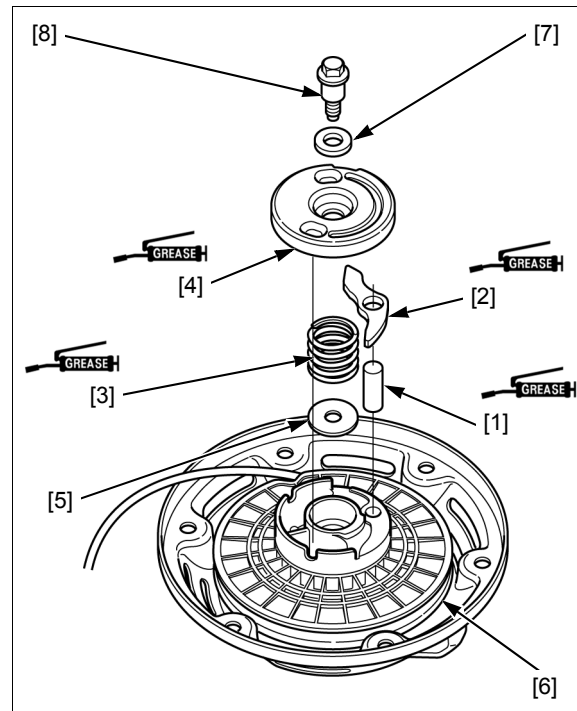

Turn the starter reel [1] counterclockwise twice to preload the return spring.
Be sure to hold the starter reel.

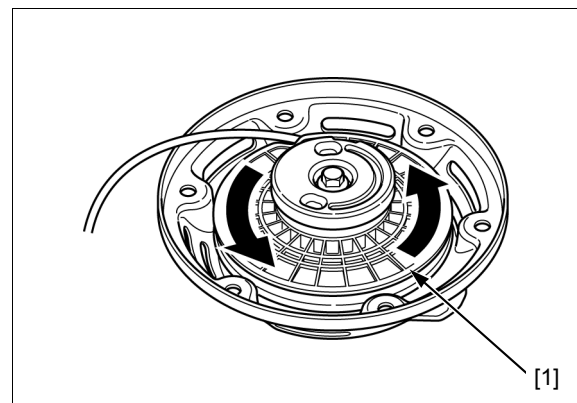

Pass the end of the recoil starter rope [1] through the rope hole [2] in the recoil starter case and install the recoil starter grip [3], and make a figure eight knot at the rope end.

Check the operation (page 8-6).

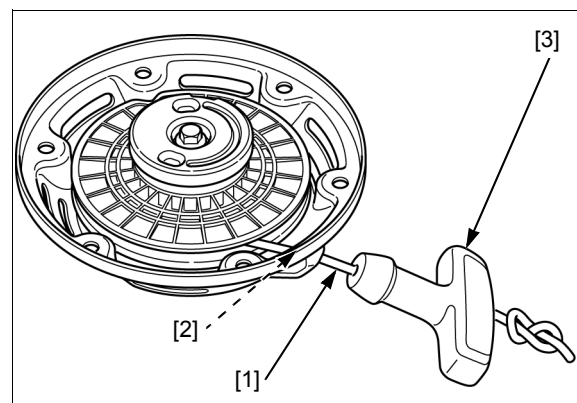

STARTING SYSTEM

RECOIL STARTER INSPECTION

Check the operation of the ratchet [1] by pulling the recoil starter rope out several times.

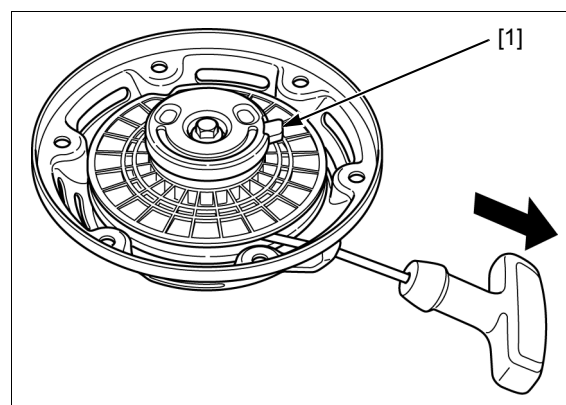

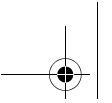

9. MUFFLER

MUFFLER REMOVAL/INSTALLATION.....9-2

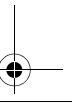
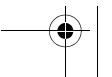
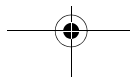
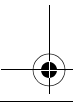
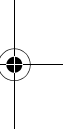
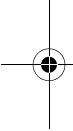

MUFFLER

MUFFLER REMOVAL/INSTALLATION

⚠ CAUTION

The engine and muffler become very hot during operation and they remain hot for a while after the operation.
The muffler removal must be done while the engine is cold.

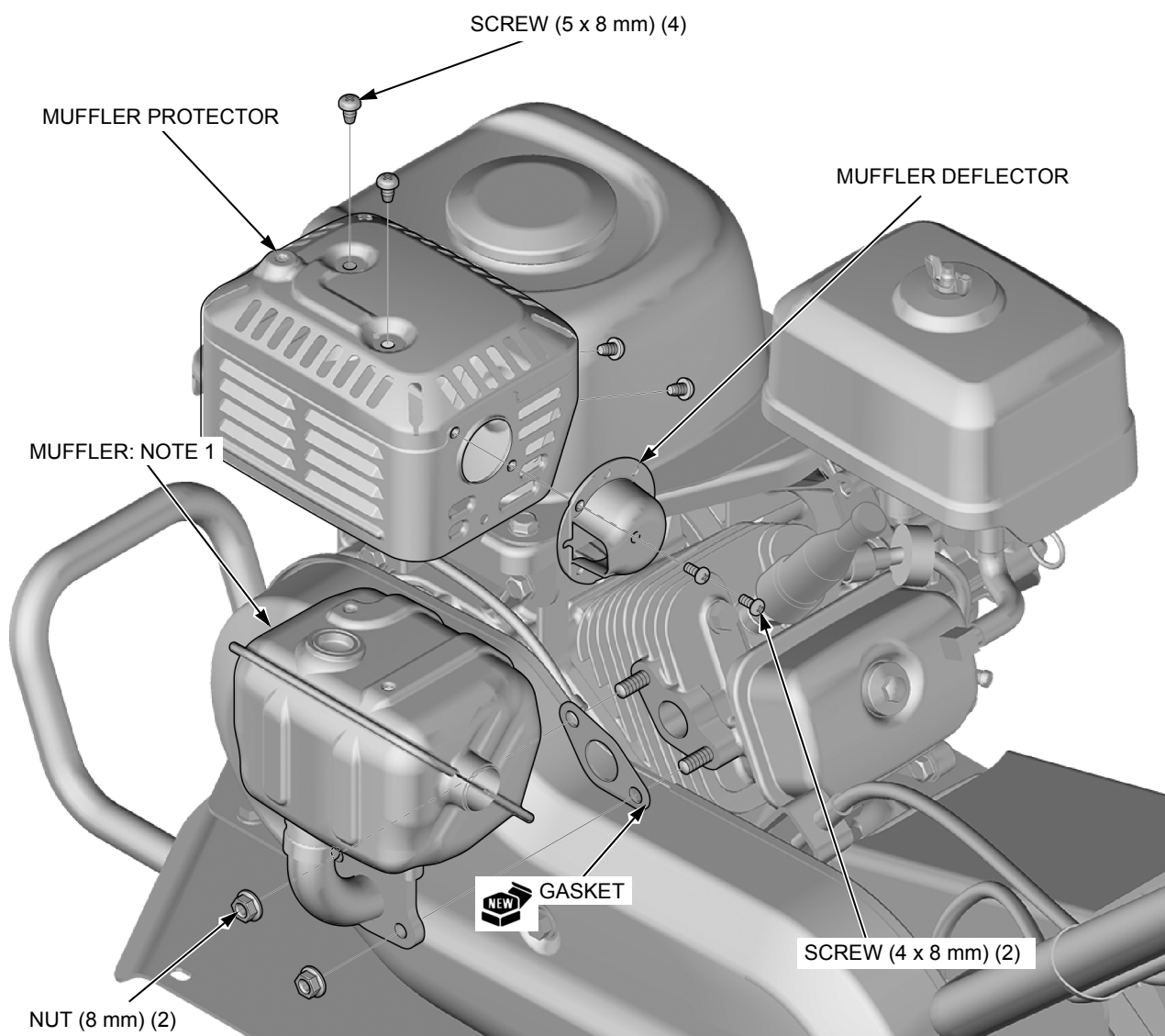

NOTE 1	Before installation, remove the carbon deposits with a plastic hammer.	-
--------	--	---

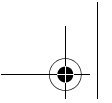

10. ENGINE REMOVAL/INSTALLATION

ENGINE REMOVAL/INSTALLATION10-2

ENGINE REMOVAL/INSTALLATION

ENGINE REMOVAL/INSTALLATION

NOTE:

- Before installation, route the wire harness properly (page 2-7)

Remove the following:

- Inner belt cover (page 11-2)
- Air cleaner (page 5-4)
- Fuel tank (page 5-3)

When installing the engine, adjust the distance between both axes to the following value:

For more detail, go to BELT TENSION ADJUSTMENT (page 3-12)

Default value: 245 – 246 mm (9.65 – 9.69 in)

After installation, adjust the V-belt tension (page 3-11).

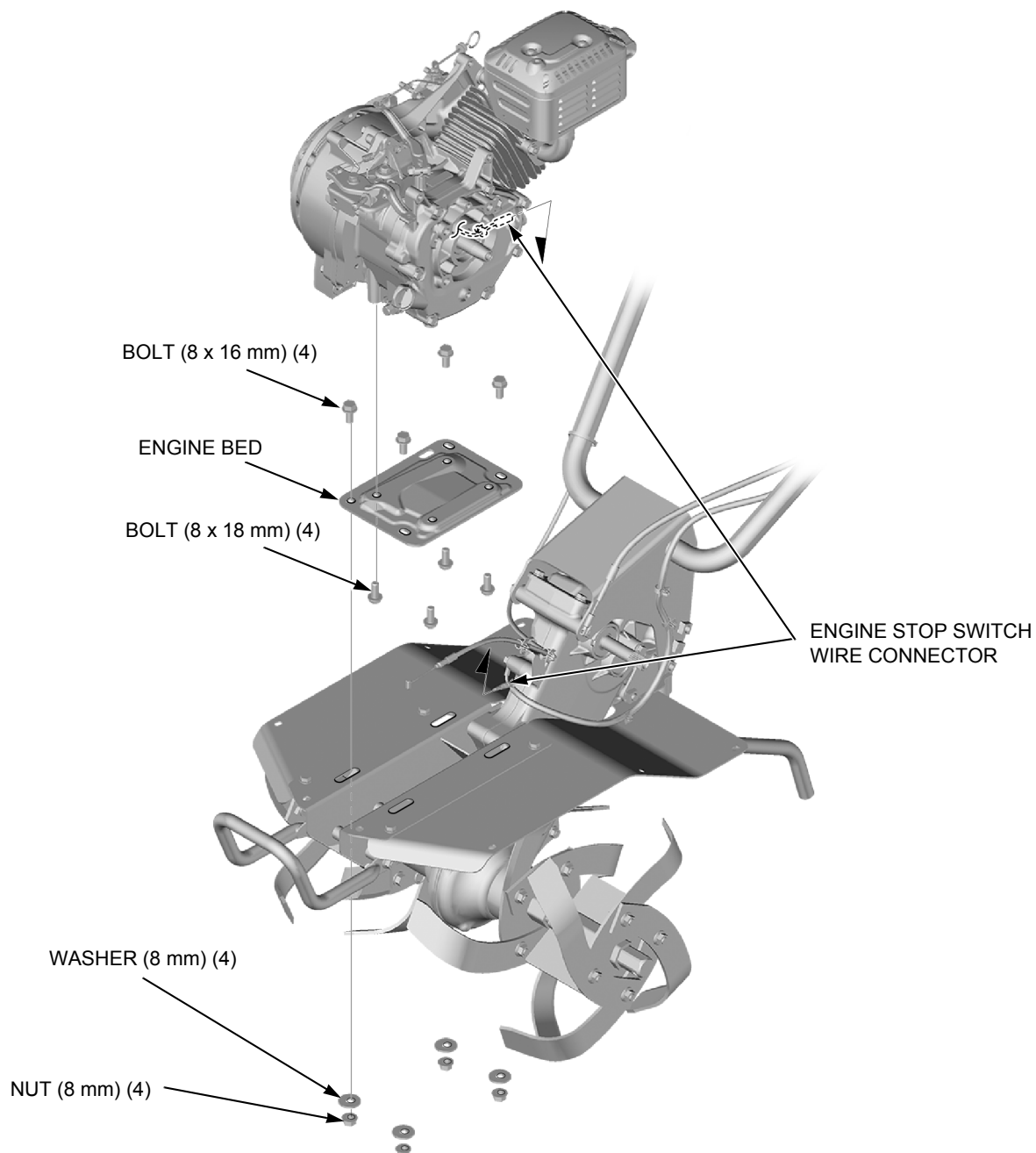
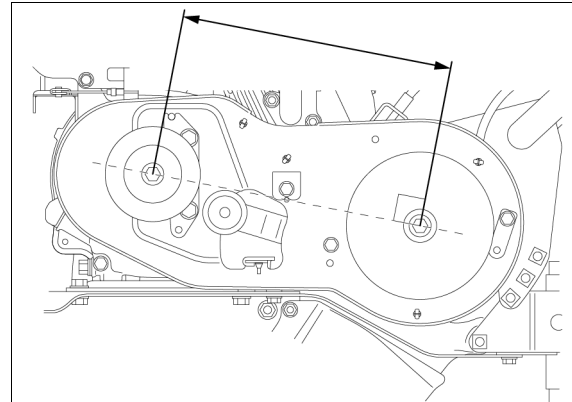

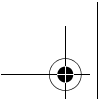

11. CLUTCH

**PULLEY/V-BELT REMOVAL/
INSTALLATION**.....11-2

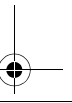
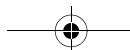
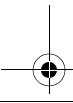
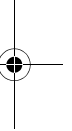
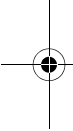

CLUTCH

PULLEY/V-BELT REMOVAL/INSTALLATION

After installation, adjust the V-belt tension (page 3-11).

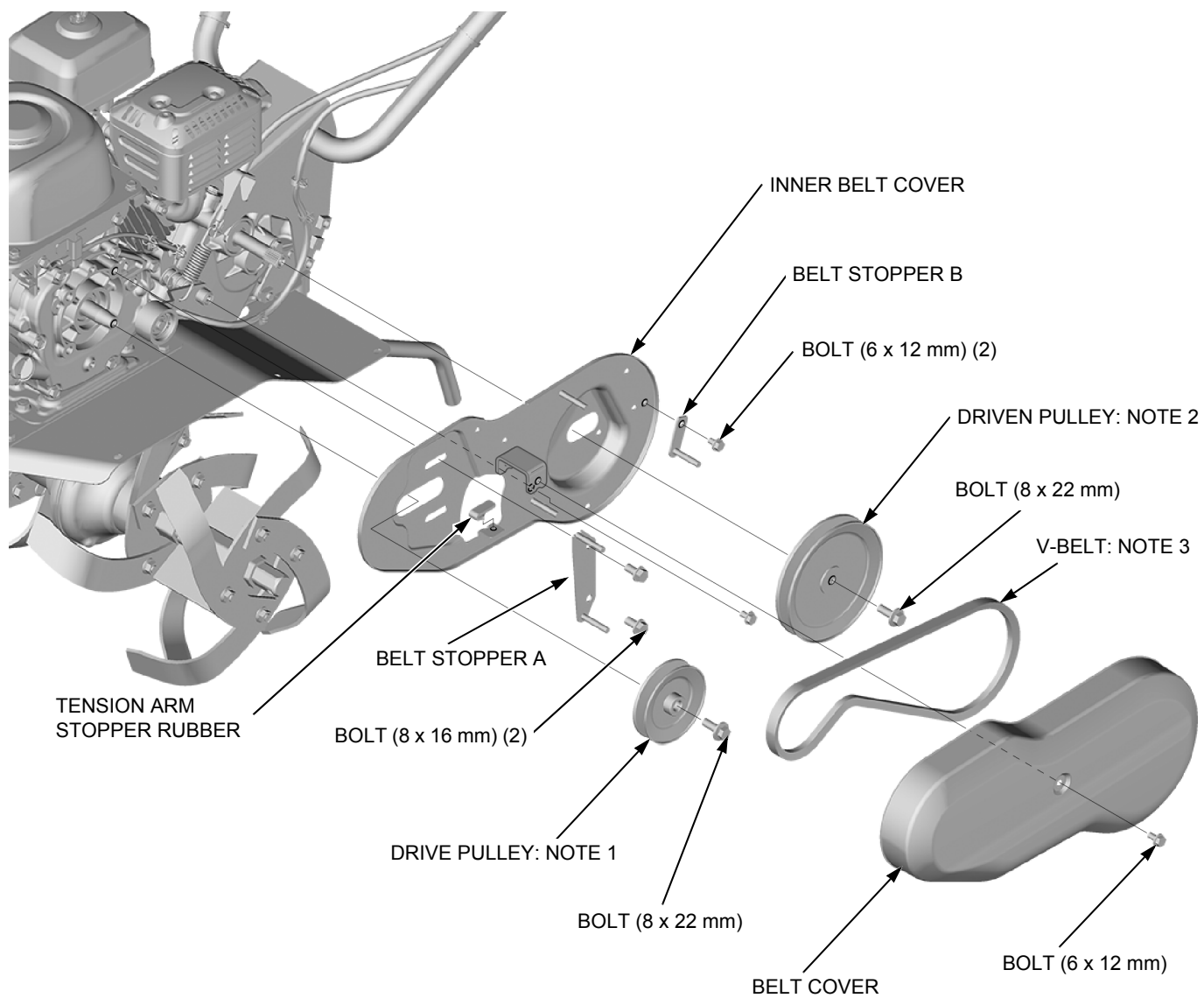

NOTE 1	DRIVE PULLEY REMOVAL/INSTALLATION	page 11-3
NOTE 2	DRIVEN PULLEY REMOVAL/INSTALLATION	page 11-3
NOTE 3	Before installation, check that there is no crack and abnormal wear-out in the belt. Replace it if necessary.	-

CLUTCH**DRIVE PULLEY REMOVAL/INSTALLATION****NOTICE**

- *Take care not to damage the drive pulley with the strap wrench.*

Hold the drive pulley [1] with a commercially available strap wrench [2] and remove the drive pulley bolt (8 x 22 mm) [3].

Screw in a bolt (12 x 1.5 mm) [4] to remove the drive pulley.

Install the drive pulley and bolt.

Hold the drive pulley with a commercially available strap wrench and tighten the bolt securely.

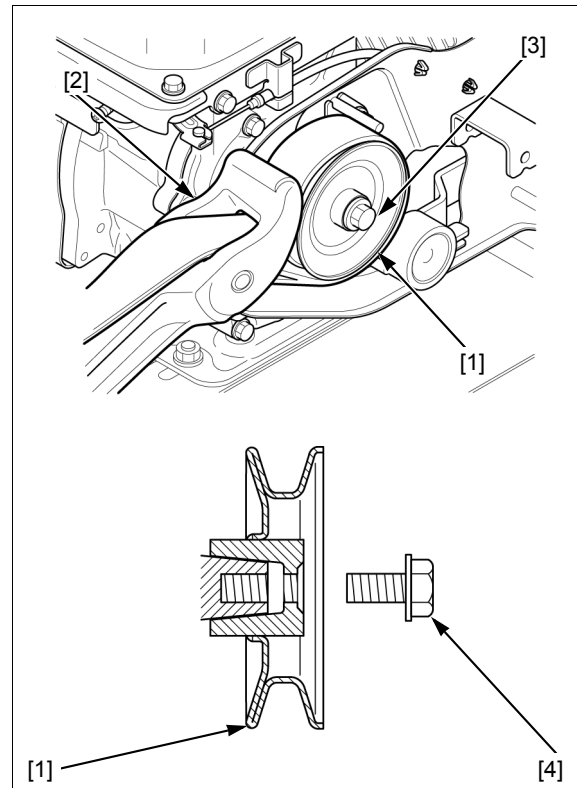
**DRIVEN PULLEY REMOVAL/INSTALLATION****NOTICE**

- *Take care not to damage the driven pulley with the strap wrench.*

Hold the driven pulley [1] with a commercially available strap wrench [2] and remove the bolt (8 x 22 mm) [3].

Install the driven pulley and bolt.

Hold the driven pulley with a commercially available strap wrench and tighten the bolt securely.

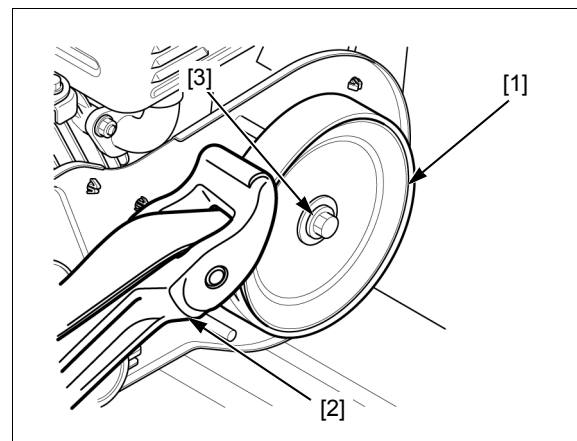

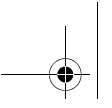

MEMO

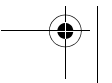
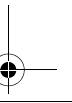
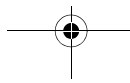
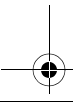
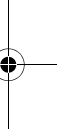
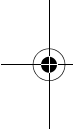

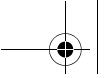

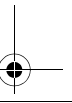
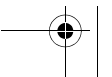
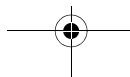
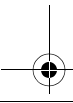
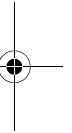
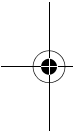

12. CYLINDER HEAD

TOOLS	12-2	CYLINDER HEAD/ VALVES INSPECTION	12-5
CYLINDER HEAD REMOVAL/ INSTALLATION	12-3	VALVE GUIDE REPLACEMENT	12-9
CYLINDER HEAD DISASSEMBLY/ ASSEMBLY	12-4	VALVE GUIDE REAMING	12-10
		VALVE SEAT RECONDITIONING	12-11



CYLINDER HEAD

TOOLS

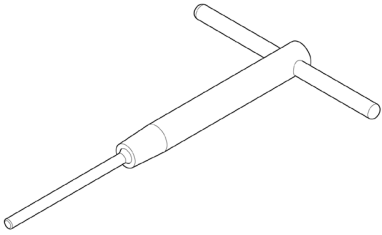
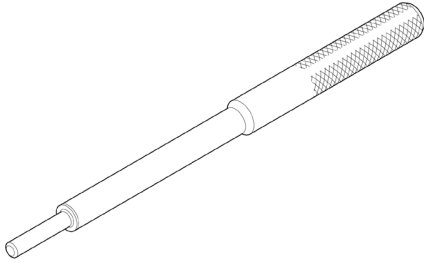
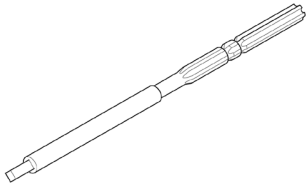
<p>Seat cutter, 20.5 mm (45° IN/EX) 07780-0011000</p> 	<p>Flat cutter, 20 mm (32° IN/EX) 07780-0013200</p> 	<p>Interior cutter, 20.5 mm (60° IN/EX) 07780-0014300</p> 
<p>Cutter holder, 5.0 mm 07781-0010400</p> 	<p>Valve guide driver, 5 mm 07942-MA60000</p> 	<p>Valve guide reamer 5.010 mm 07984-MA60001</p> 

CYLINDER HEAD

CYLINDER HEAD REMOVAL/INSTALLATION

Set the piston at top dead center of the cylinder compression stroke (page 3-14).

Remove the fan cover (page 7-3).

After installation, inspect following:

- Valve clearance (page 3-14)
- Cylinder compression (page 12-5)

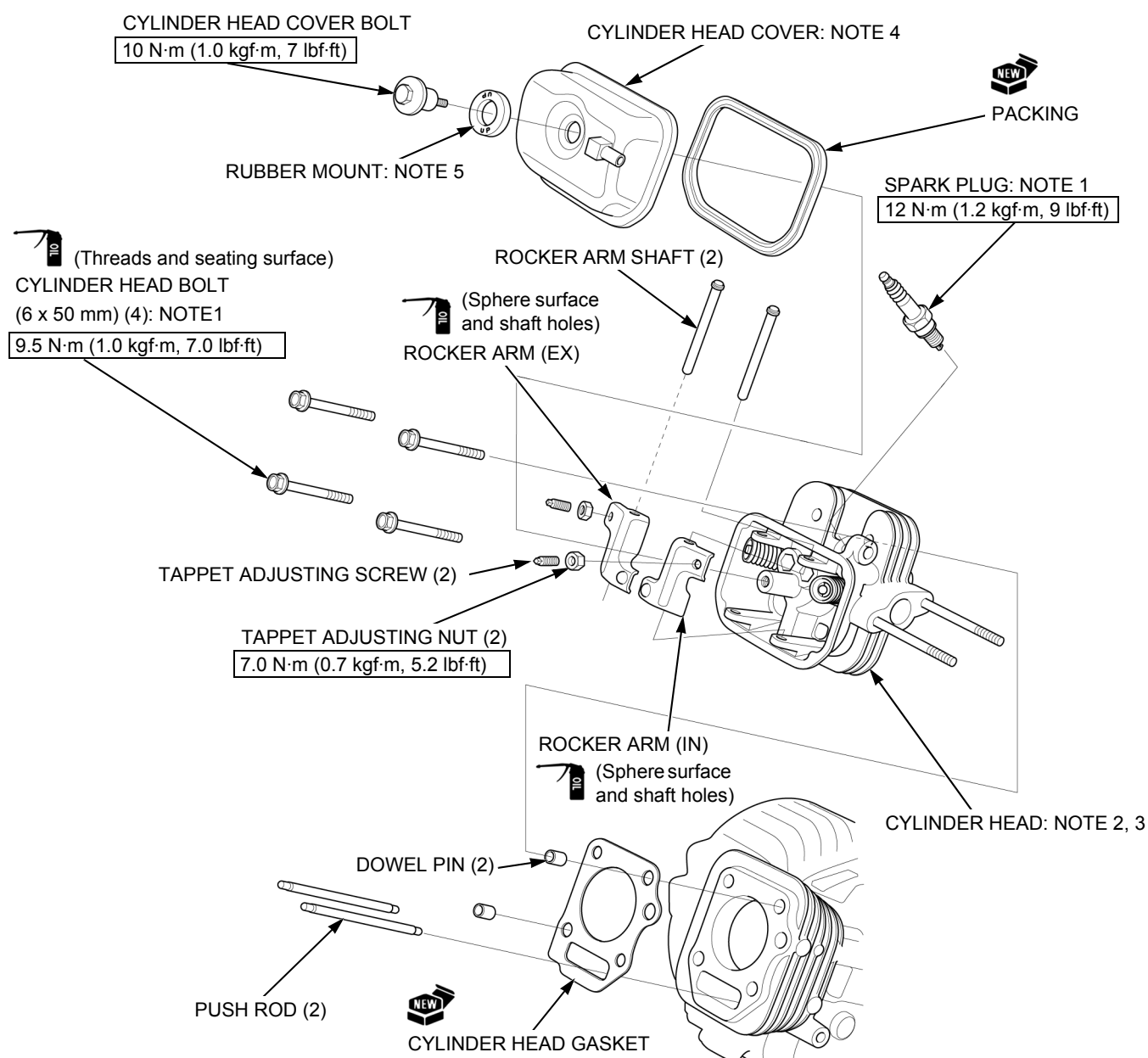

NOTE 1	SPARK PLUG CHECK/ADJUSTMENT/REPLACEMENT	page 3-9
NOTE 2	CYLINDER HEAD DISASSEMBLY/ASSEMBLY	page 12-4
NOTE 3	Before installation, remove any carbon deposits from the combustion chamber and inspect the valve seats.	-
NOTE 4	<ul style="list-style-type: none"> • When removing, pry off slowly at each corner of the head cover. • Using too much force can deform the cylinder head cover. The cylinder head cover must be replaced if it is deformed. 	-
NOTE 5	Install the rubber mount with a mark facing up.	-
NOTE 6	REMOVAL/INSTALLATION: Loosen and tighten the bolts diagonally several times.	-

CYLINDER HEAD

CYLINDER HEAD DISASSEMBLY/ASSEMBLY

Remove the cylinder head (page 12-3).

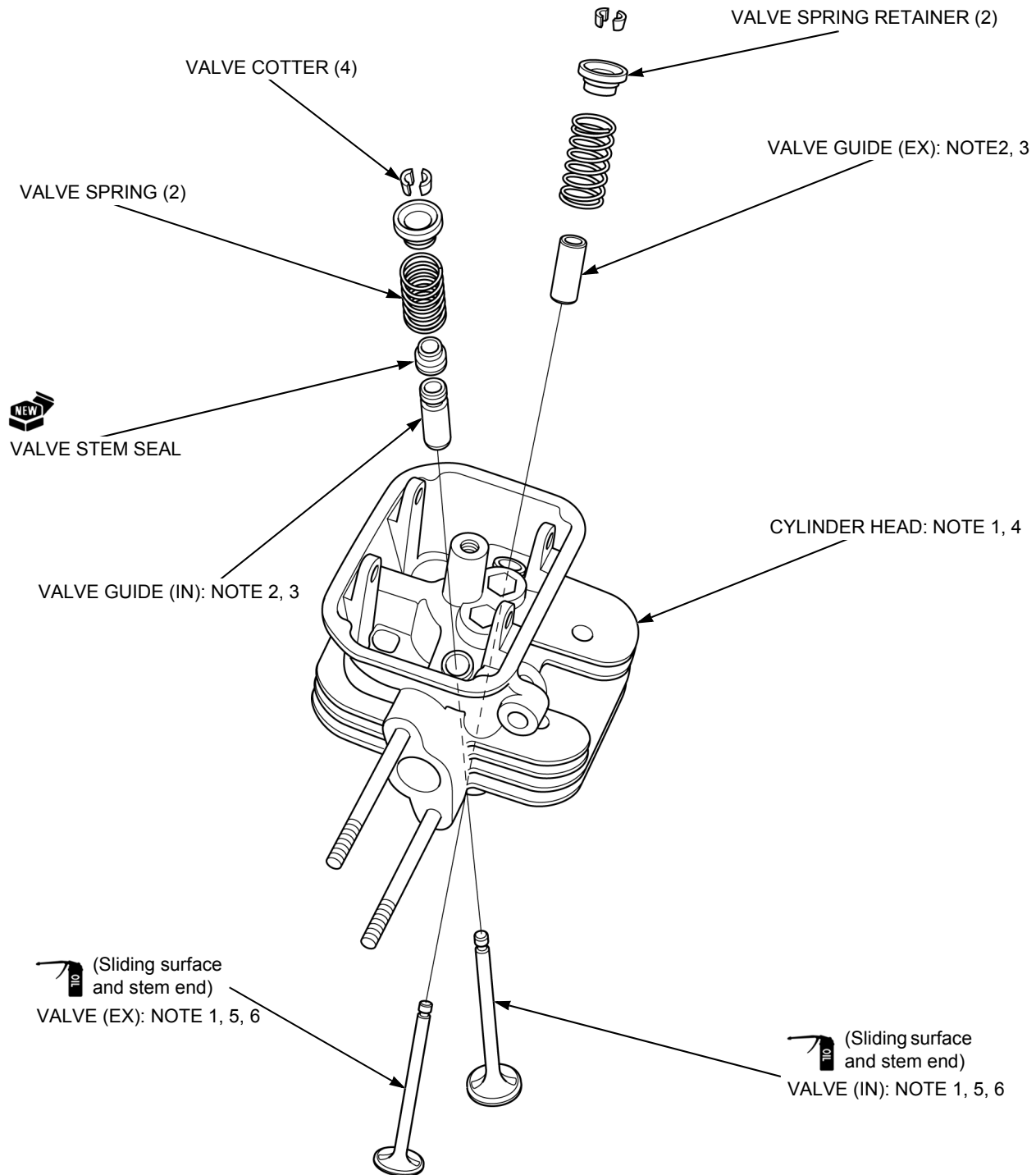

NOTE 1	CYLINDER HEAD/VALVES INSPECTION	page 12-5
NOTE 2	VALVE GUIDE REPLACEMENT	page 12-9
NOTE 3	VALVE GUIDE REAMING	page 12-10
NOTE 4	VALVE SEAT RECONDITIONING	page 12-11
NOTE 5	Do not interchange the valves. VALVE HEAD DIAMETER: IN: 18 mm (0.71 in) EX: 17 mm (0.67 in)	-
NOTE 6	Before installation, remove carbon deposits.	-

CYLINDER HEAD
**CYLINDER HEAD/VALVES
INSPECTION**
CYLINDER COMPRESSION CHECK

Start the engine and warm up to normal operating temperature.

Turn off the engine stop switch to stop the engine.

Turn the fuel valve lever to the OFF position, and then loosen the drain screw of the carburetor to drain the fuel completely.

Remove the spark plug (page 3-9).

Pull the recoil starter several times to expel unburned gas.

Attach a commercially available compression gauge [1] to the spark plug hole.

Pull the recoil starter forcefully to measure stable cylinder compression.

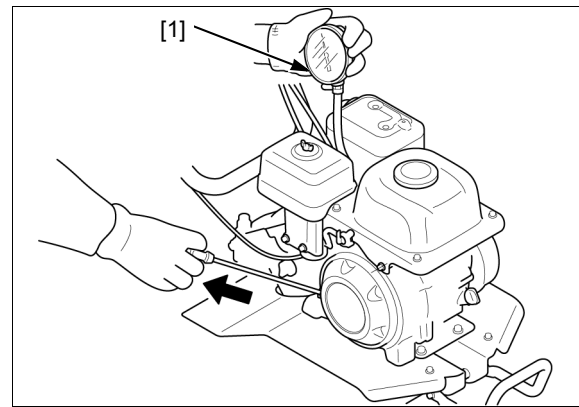
CYLINDER COMPRESSION:

0.50 MPa (5.1 kgf/cm², 73 psi)/600 min⁻¹ (rpm)

CYLINDER HEAD WARPAGE

Remove the carbon deposits from the combustion chamber (page 3-15).

Clear off any gasket material from the cylinder head mating surface.

Check the spark plug hole and valve areas for cracks.

Check the cylinder head warpage using a straight edge [1] and thickness gauge [2].

NOTE:

- Be careful not to damage the mating surface.

SERVICE LIMIT: 0.10 mm (0.004 in)

If the measurement is more than the service limit, replace the cylinder head.

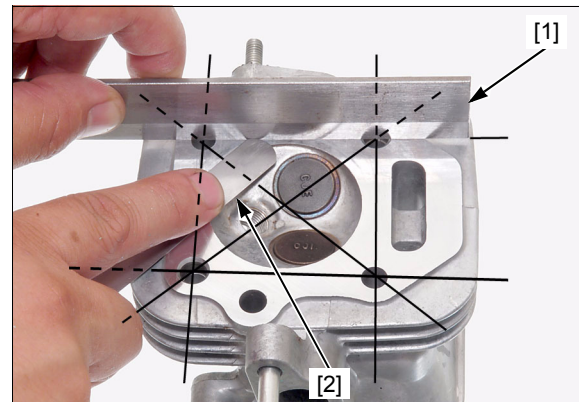

CYLINDER HEAD

ROCKER ARM SHAFT O.D./ROCKER ARM I.D./ROCKER ARM SHAFT HOLDER I.D.

Measure the rocker arm shaft O.D.

STANDARD: 5.952 – 6.000 mm (0.2343 – 0.2362 in)

SERVICE LIMIT: 5.94 mm (0.234 in)

If the measurement is less than the service limit, replace the rocker arm shaft (page 12-3).

Measure the rocker arm I.D.

STANDARD: 6.000 – 6.030 mm (0.2362 – 0.2374 in)

SERVICE LIMIT: 6.04 mm (0.238 in)

If the measurement is more than the service limit, replace the rocker arm (page 12-3).

Measure the rocker arm shaft holder I.D.

STANDARD: 6.010 – 6.022 mm (0.2366 – 0.2371 in)

SERVICE LIMIT: 6.04 mm (0.238 in)

If the measurement is more than the service limit, replace the cylinder head (page 12-3).

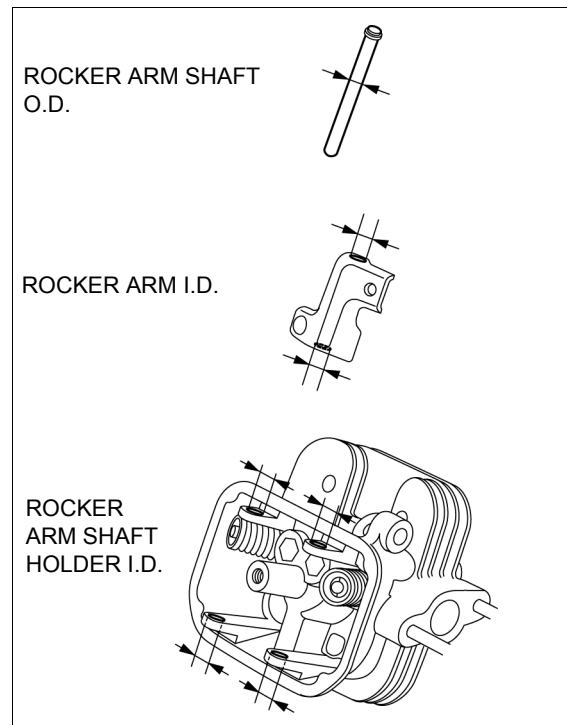

VALVE SEAT WIDTH

Remove the carbon deposits from the combustion chamber (page 3-15).

Inspect each valve face for irregularities.

If necessary, replace the valve.

Apply a light coat of Prussian Blue or erasable felt-tipped marker ink to the each valve seat.

Insert the valve, and snap it closed against its seat several times using a valve lapper [1]. Be sure the valve does not rotate on the seat.

The transferred marking compound will show any area of the valve face that is not concentric.

Measure the valve seat width of the cylinder head.

STANDARD:

IN/EX: 0.7 – 0.9 mm (0.03 – 0.04 in)

SERVICE LIMIT: 2.0 mm (0.08 in)

If the measurement is more than the service limit, recondition the valve seat (page 12-11).

Check whether the valve seat contact area of the valve is too high.

If the valve seat is too high or too low, recondition the valve seat (page 12-11).

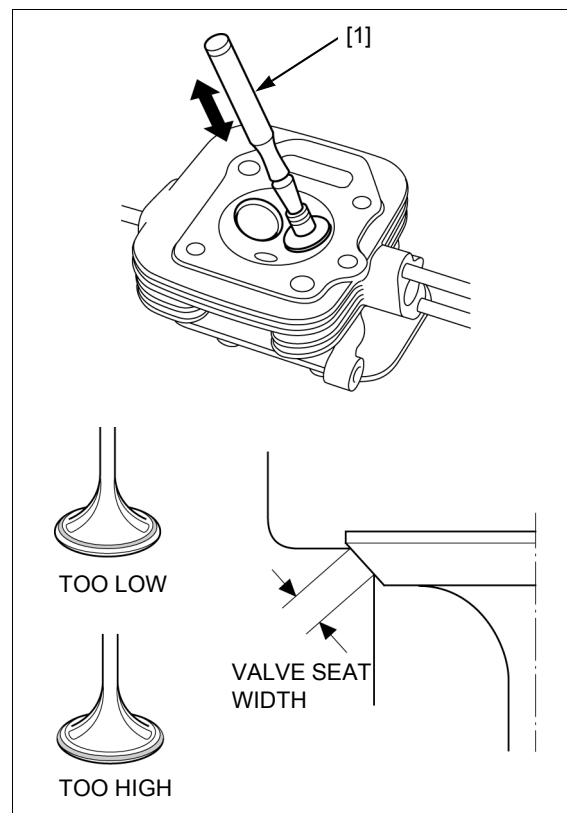

CYLINDER HEAD**VALVE GUIDE I.D.**

Ream the valve guide [1] to remove any carbon deposits before measuring.

TOOL:

Valve guide reamer 5.010 mm [2] 07984-MA60001

NOTICE

- Turn the valve guide reamer (special tool) clockwise, never counterclockwise.
- Continue to rotate the special tool while removing it from the valve guide.

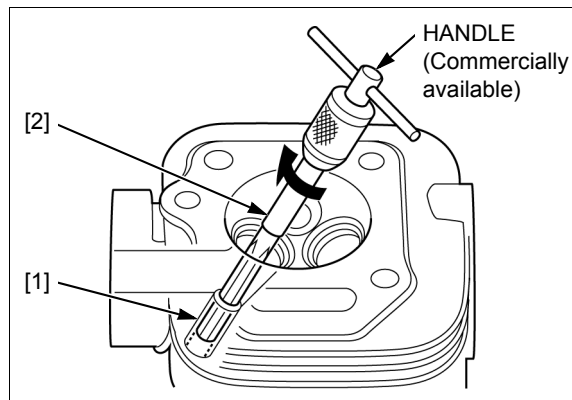

Measure and record each valve guide I.D.

STANDARD: 5.000 – 5.012 mm (0.1969 – 0.1973 in)

SERVICE LIMIT: 5.03 mm (0.198 in)

If the measured valve guide I.D. is more than the service limit, replace the valve guide (page 12-9).

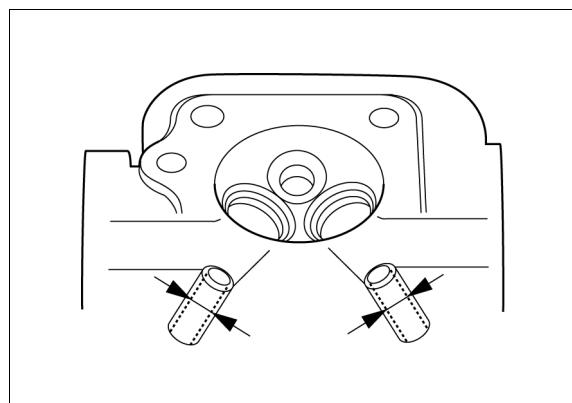
**VALVE STEM O.D.**

Inspect each valve for bending or abnormal stem wear.

If necessary, replace the valve.

Measure and record each valve stem O.D.

STANDARD:

IN: 4.975 – 4.990 mm (0.1959 – 0.1965 in)

EX: 4.960 – 4.970 mm (0.1953 – 0.1957 in)

SERVICE LIMIT:

IN: 4.97 mm (0.196 in)

EX: 4.95 mm (0.195 in)

If the measurement is less than the service limit, replace the valve.

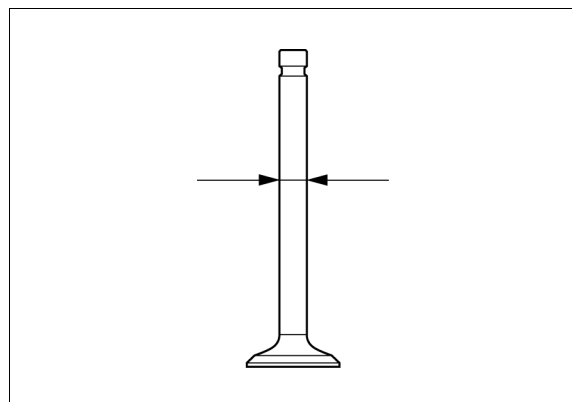
**GUIDE-TO-STEM CLEARANCE**

Subtract each valve stem O.D. from the corresponding valve guide I.D. to obtain the stem-to-guide clearance.

STANDARD:

IN: 0.010 – 0.037 mm (0.0004 – 0.0015 in)

EX: 0.030 – 0.057 mm (0.0012 – 0.0022 in)

SERVICE LIMIT:

IN: 0.060 mm (0.0024 in)

EX: 0.080 mm (0.0031 in)

If the calculated clearance is more than the service limit, replace the valve and valve guide respectively (page 12-9).

CYLINDER HEAD

VALVE SPRING FREE LENGTH/ PERPENDICULARITY

Measure the free length of the valve spring.

STANDARD: 29.5 mm (1.16 in)

SERVICE LIMIT: 28.3 mm (1.11 in)

If the measured length is less than the service limit, replace the valve spring.

Measure the valve spring perpendicularity.

SERVICE LIMIT: 2° max.

If the measured perpendicularity is more than the service limit, replace the valve spring.

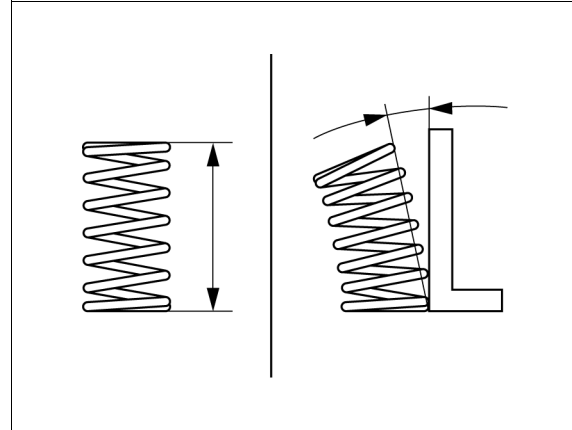

PUSH ROD RUNOUT

Check both ends of the push rod for wear.

Check the push rod for straightness.

If necessary, replace the push rod.

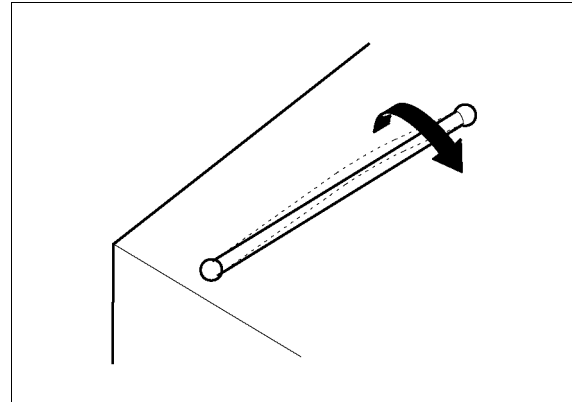

CYLINDER HEAD

VALVE GUIDE REPLACEMENT

Chill the replacement valve guides in the freezer section of a refrigerator for about an hour.

Use a hot plate or oven to heat the cylinder head evenly to 150°C (302°F).

CAUTION

To avoid burns, use heavy gloves when handling the heated cylinder head.

NOTICE

- Do not use a torch to heat the cylinder head; warpage of the cylinder head may result.
- Do not get the cylinder head hotter than 150°C (302°F); excessive heat may loosen the valve seats.

Remove the heated cylinder head from the hot plate and support it with wooden blocks.

From the combustion chamber side, strike the valve guides [1] secured in the cylinder head with a hammer to be removed them.

TOOL:

Valve guide driver, 5 mm [2] 07942-MA60000

NOTICE

- When removing the valve guides, be careful not to damage the cylinder head.

Take the new valve guides [1] from the refrigerator as needed.

Install the valve guides from the valve spring side of the cylinder head.

TOOL:

Valve guide driver, 5 mm [2] 07942-MA60000

Install the exhaust valve guide in the specified height (measured from the end of the valve guide to the cylinder head as shown).

Install the intake valve guide in the specified height (measured from the end of the valve guide to the cylinder head as shown).

VALVE GUIDE INSTALLATION HEIGHT:

IN: 5.8 – 6.2 mm (0.23 – 0.24 in)

EX: 3.3 – 3.7 mm (0.13 – 0.15 in)

After installing the valve guide, check the guide for damage.

Replace the valve guide if damaged.

Let the cylinder head cool to room temperature.

Perform valve guide reaming (page 12-10).

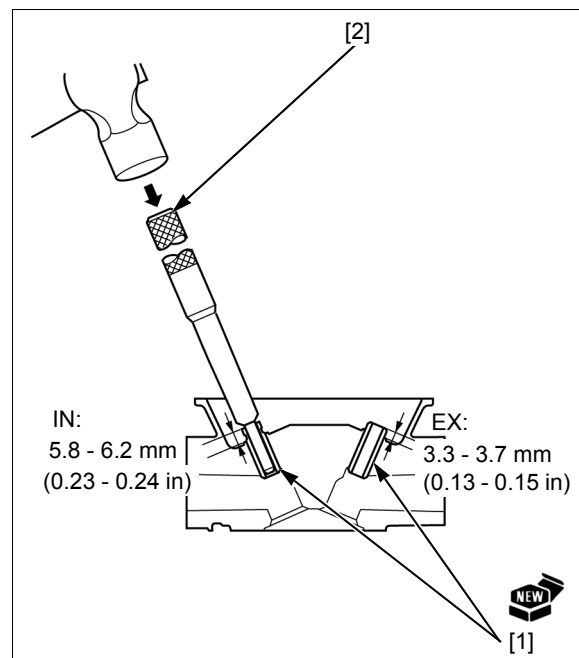
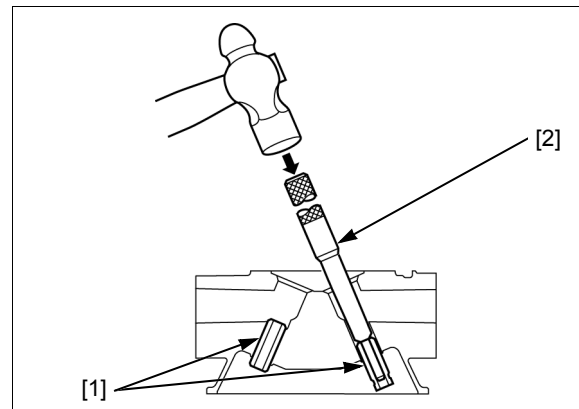

CYLINDER HEAD

VALVE GUIDE REAMING

Make sure the cylinder head is as cool as a room temperature before reaming valve guides [1].

Coat the reamer and valve guide with cutting oil.

Rotate the reamer clockwise into the valve guide completely.

TOOL:

Valve guide reamer 5.010 mm [2] 07984-MA60001

NOTICE

- Turn the valve guide reamer (special tool) clockwise, never counterclockwise.
- Continue to rotate the special tool while removing it from the valve guide.

Thoroughly clean the cylinder head to remove any cutting residue.

Check the valve guide bore; it should be straight, round and centered in the valve guide. Insert the valve and check operation. If the valve does not operate smoothly, the guide may have been bent during installation.

Replace the valve guide if it is bent or damaged (page 12-9).

Check the valve guide-to-stem clearance (page 12-7).

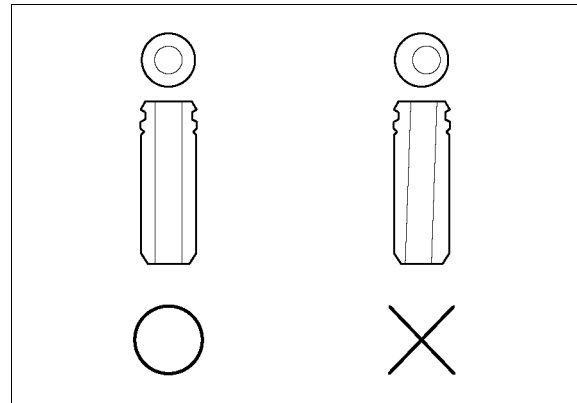
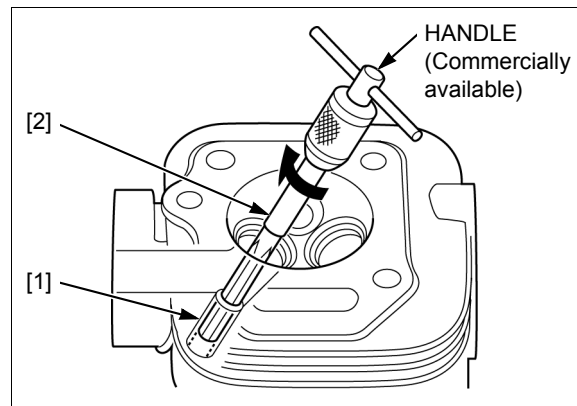

CYLINDER HEAD

VALVE SEAT RECONDITIONING

Inspect the valve seat contact area (page 12-6).

Using a 45° seat cutter, remove any roughness or irregularities from the seat.

If the contact area is too low on the valve, the seat must be raised using a 60° interior cutter.

If the contact area is too high on the valve, the seat must be lowered using a 32° flat cutter.

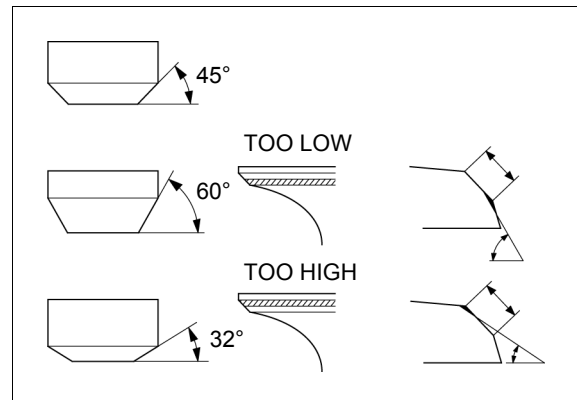

Valve seat cutters [1]/grinder or equivalent valve seat refacing equipment is recommended to correct a worn valve seat.

NOTICE

- Turn the cutter clockwise, never counterclockwise.
- Continue to turn the cutter as you lift it from the valve seat.

TOOLS:

Cutter holder, 5.0 mm	07781-0010400
Seat cutter, 20.5 mm (45° IN/EX)	07780-0011000
Flat cutter, 20 mm (32° IN/EX)	07780-0013200
Interior cutter, 20.5 mm (60° IN/EX)	07780-0014300

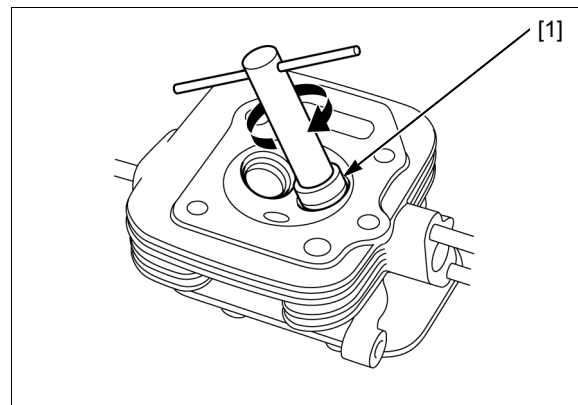

Remove any possible burrs at the edge of the seat with the 45° cutter.

Be sure that the width of the finished valve seat is within specification.

STANDARD:

IN/EX: 0.7 – 0.9 mm (0.03 – 0.04 in)

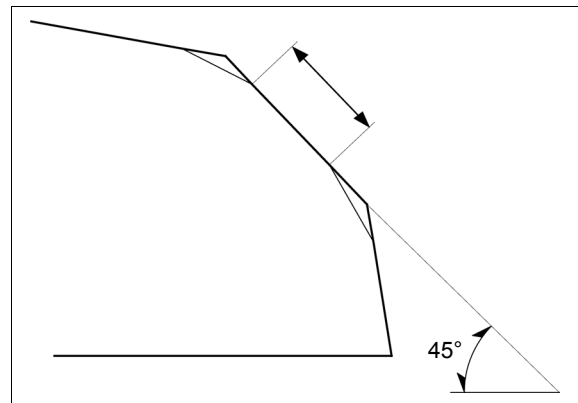

Lap the valves into their seats, using a commercially available valve lapper [1] and lapping compound.

After lapping, wash all residual compound off the cylinder head and valve.

NOTICE

- Do not push the valve against the seat with force during lapping. Apply a light pass with the valve lapper.
- Avoid lapping the valve in the same position as it causes uneven wear. Lap the valve by turning the lapper slowly.
- Take care not to allow the lapping compound to enter the gap between the stem and guide.

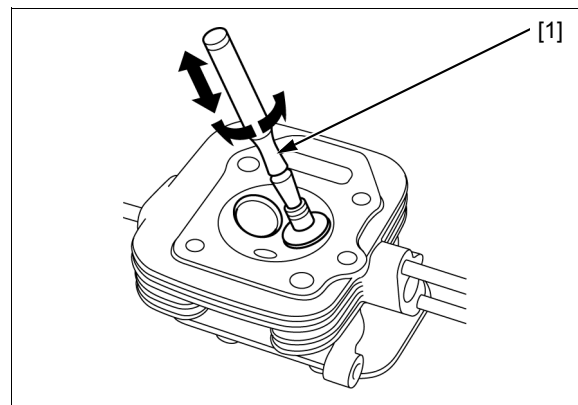

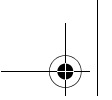

MEMO

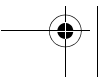
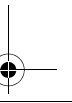
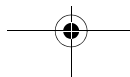
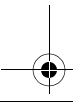
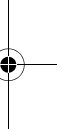
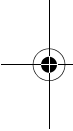

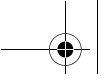



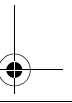
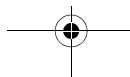
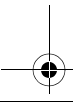
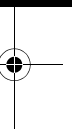
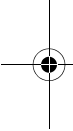

13. CYLINDER BLOCK

TOOLS	13-2	CRANKCASE COVER/CYLINDER BLOCK/ PISTON/CONNECTING ROD/CRANKSHAFT/ CAMSHAFT INSPECTION	13-6
CRANKCASE COVER/CRANKSHAFT/ CAMSHAFT/PISTON REMOVAL/ INSTALLATION	13-3	CRANKSHAFT BEARING/OIL SEAL REPLACEMENT	13-12
PISTON DISASSEMBLY/ASSEMBLY	13-5		



CYLINDER BLOCK

TOOLS

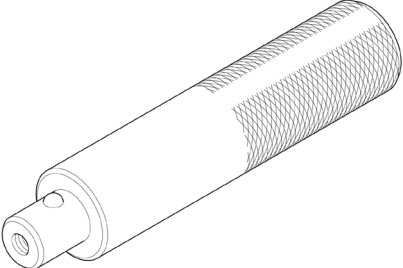
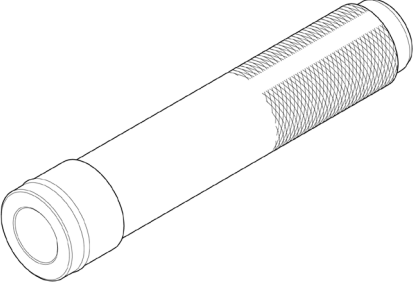
<p>Pilot, 17 mm 07746-0040400</p> 	<p>Attachment 37 × 40 mm 07746-0010200</p> 	<p>Attachment 27 × 30 mm 07946-1870100</p> 
<p>Inner bearing drive attachment 17 mm 07746-0020300</p> 	<p>Driver 07749-0010000</p> 	<p>Driver, 22 mm I.D. 07746-0020100</p> 

CYLINDER BLOCK

**CRANKCASE COVER/CRANKSHAFT/
CAMSHAFT/PISTON REMOVAL/
INSTALLATION**

Drain the engine oil (page 3-4).

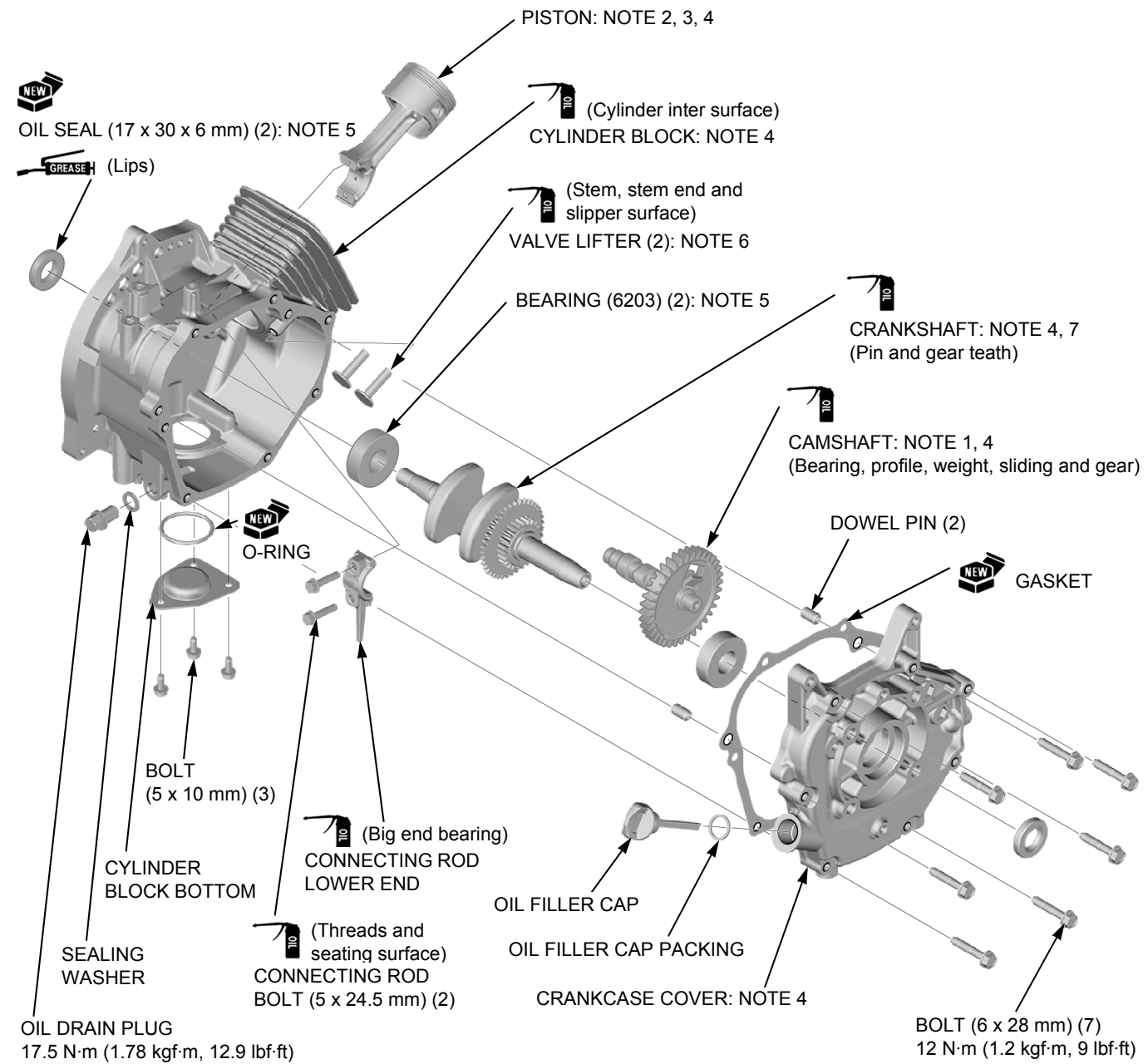

NOTE 1	CAMSHAFT INSTALLATION	page 13-4
NOTE 2	PISTON DISASSEMBLY/ASSEMBLY	page 13-5
NOTE 3	PISTON INSTALLATION	page 13-4
NOTE 4	CRANKCASE COVER/CYLINDER BLOCK/PISTON/CONNECTING ROD/ CRANKSHAFT/CAMSHAFT INSPECTION	page 13-6
NOTE 5	CRANKSHAFT BEARING/OIL SEAL REPLACEMENT	page 13-12
NOTE 6	When disassembly, mark so that the IN and EX sides can be distinguished.	-
NOTE 7	When reassembly, push in until the bearing touches the crankcase. Be careful not to damage the oil seal.	-

CYLINDER BLOCK

CAMSHAFT INSTALLATION

NOTE:

- Install the valve lifters [1] immediately before installing the camshaft [2].

Apply engine oil to the two valve lifters slipper surface, stem and stem end.

Install the valve lifters to the cylinder block [3].

Apply engine oil to the camshaft cam profile and journal.

Install the timing gear [4] of the crankshaft and camshaft by aligning the punch marks [5].

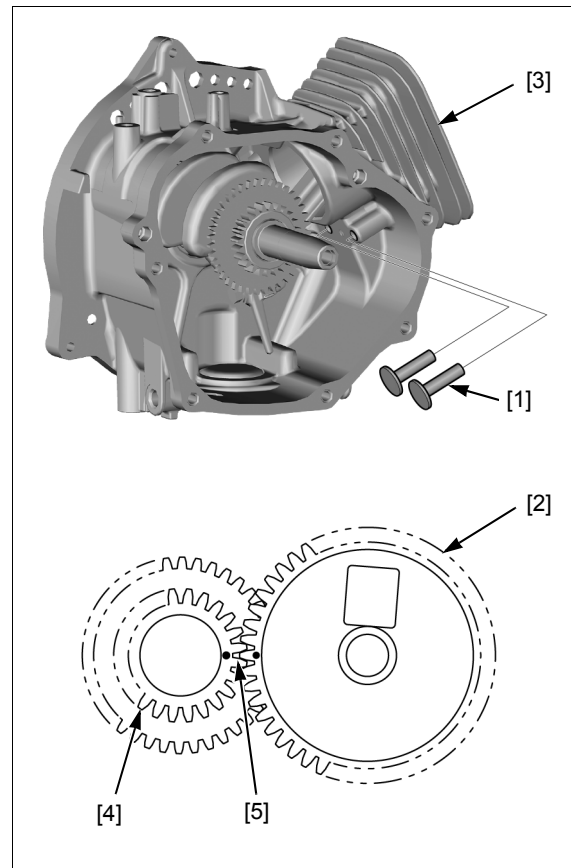

PISTON INSTALLATION

Install the piston assembly to the cylinder block with the mark [1] on the piston head toward the push rod hole [2] of the cylinder block.

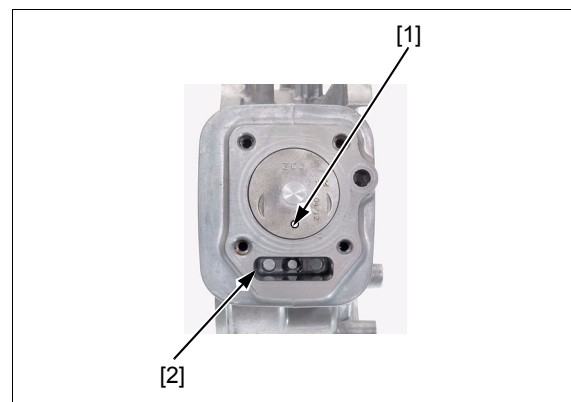

CYLINDER BLOCK

PISTON DISASSEMBLY/ASSEMBLY

Remove the piston (page 13-3).

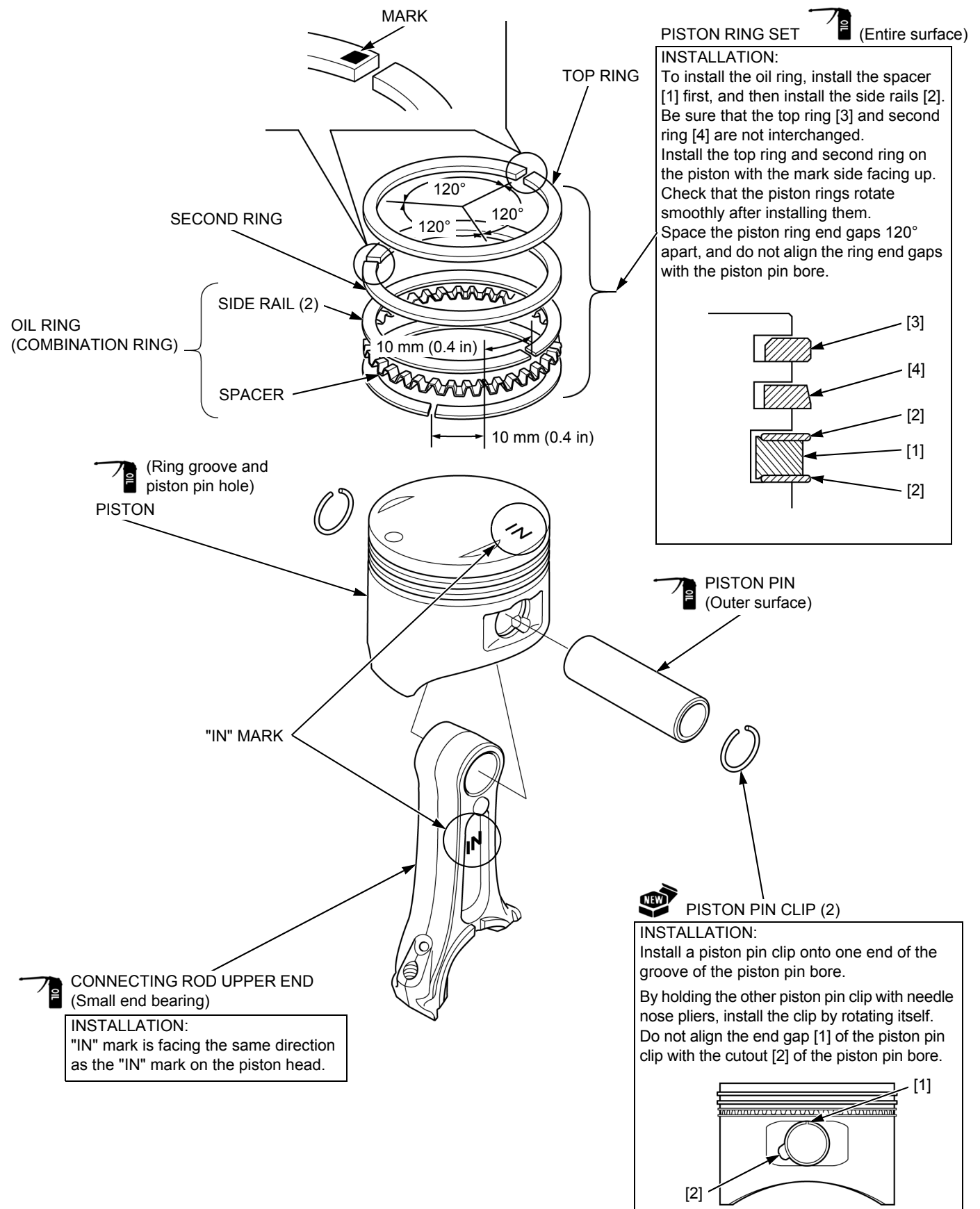

CYLINDER BLOCK

CRANKCASE COVER/CYLINDER BLOCK/PISTON/CONNECTING ROD/CRANKSHAFT/CAMSHAFT INSPECTION

CAMSHAFT HOLDER I.D.

CRANKCASE COVER SIDE

Measure the camshaft holder I.D. of the crankcase cover.

STANDARD: 10.000 – 10.015 mm (0.3937 – 0.3943 in)

SERVICE LIMIT: 10.05 mm (0.396 in)

If the measurement is more than the service limit, replace the crankcase cover.

Inspect the camshaft O.D. (page 13-11).

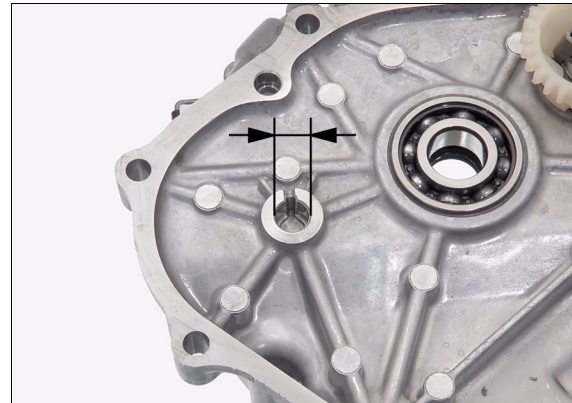

CYLINDER BLOCK SIDE

Measure the camshaft holder I.D. of the cylinder block.

STANDARD: 10.000 – 10.015 mm (0.3937 – 0.3943 in)

SERVICE LIMIT: 10.05 mm (0.396 in)

If the measurement is more than the service limit, replace the cylinder block.

Inspect the camshaft O.D. (page 13-11).

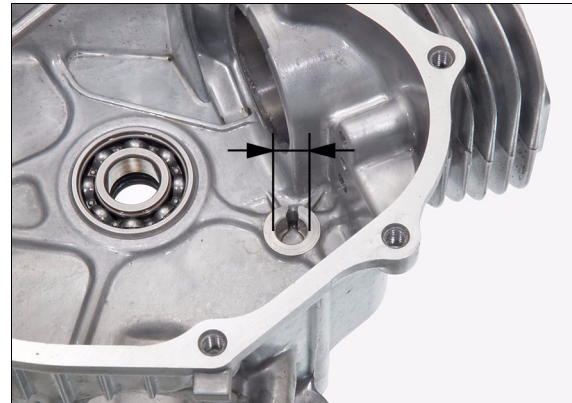

CYLINDER SLEEVE I.D.

Measure and record the cylinder I.D. at three levels in both the "X" axis (perpendicular to crankshaft) and the "Y" axis (parallel to crankshaft). Take the maximum reading to determine cylinder wear and taper.

STANDARD: 46.000 – 46.015 mm (1.8110 – 1.8116 in)

SERVICE LIMIT: 46.15 mm (1.8169 in)

If the measurement is more than the service limit, replace the cylinder block.

Inspect the piston skirt O.D. (page 13-7).

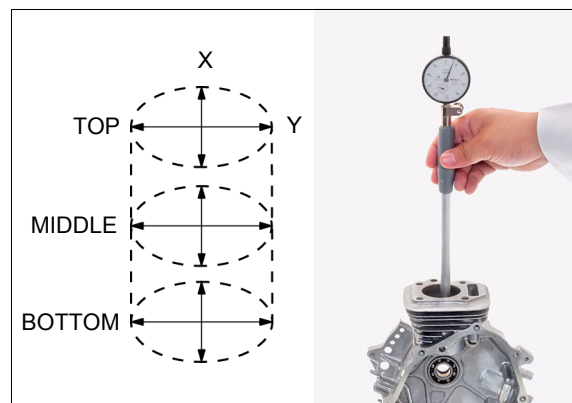

CYLINDER BLOCK**PISTON SKIRT O.D.**

Measure and record the piston O.D. at a point 10 mm (0.4 in) from the bottom of the skirt and 90° to the piston pin bore.

STANDARD: 45.965 – 45.985 mm (1.8096 – 1.8104 in)

SERVICE LIMIT: 45.87 mm (1.806 in)

If the measurement is less than the service limit, replace the piston.

Inspect the cylinder sleeve I.D. (page 13-6).

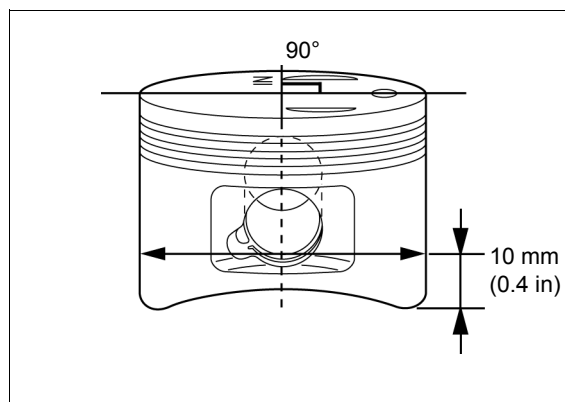
**PISTON-TO-CYLINDER CLEARANCE**

Subtract the piston skirt O.D. from the cylinder sleeve I.D. to obtain the piston-to-cylinder clearance.

STANDARD: 0.015 – 0.050 mm (0.0006 – 0.0020 in)

SERVICE LIMIT: 0.12 mm (0.005 in)

If the calculated clearance is more than the service limit, replace the piston and recheck the clearance.

If the clearance is still more than the service limit with the new piston, replace the cylinder block.

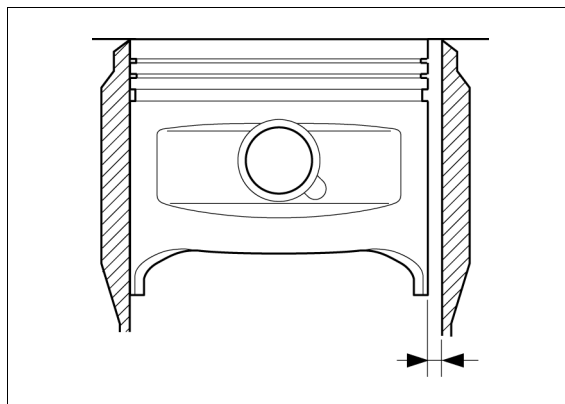
**PISTON PIN BORE I.D.**

Measure and record the piston pin bore I.D. of the piston.

STANDARD: 12.002 – 12.008 mm (0.4725 – 0.4728 in)

SERVICE LIMIT: 12.04 mm (0.474 in)

If the measurement is more than the service limit, replace the piston.

Inspect the piston pin O.D. (page 13-7).

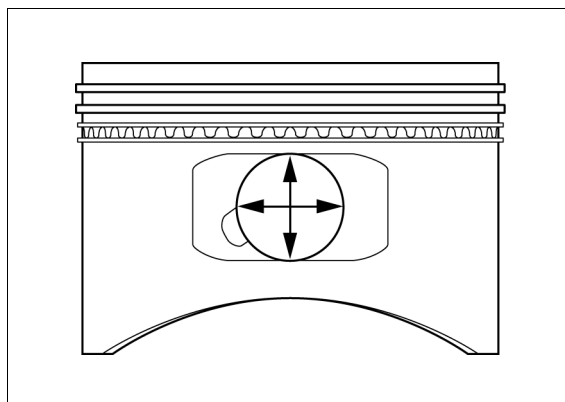
**PISTON PIN O.D.**

Measure and record the piston pin O.D. at three points (both ends and middle). Take the minimum reading to determine piston pin O.D.

STANDARD: 11.994 – 12.000 mm (0.4722 – 0.4724 in)

SERVICE LIMIT: 11.97 mm (0.471 in)

If the measurement is less than the service limit, replace the piston pin.

Inspect the piston pin bore I.D. (page 13-7).

Inspect the connecting rod small end I.D. (page 13-10).

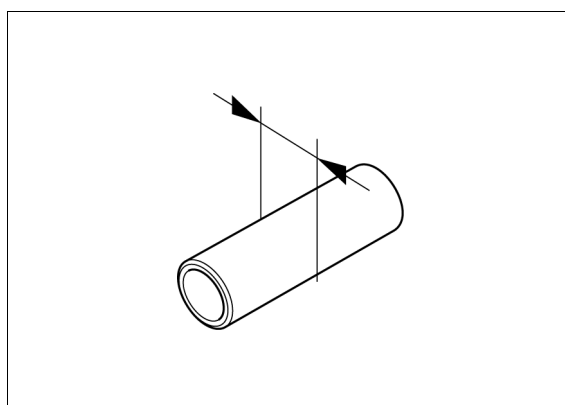

CYLINDER BLOCK

PISTON PIN-TO-PISTON PIN BORE CLEARANCE

Subtract the piston pin O.D. from the piston pin bore I.D. to obtain the piston pin-to-piston pin bore clearance.

STANDARD: 0.002 – 0.014 mm (0.0001 – 0.0006 in)

SERVICE LIMIT: 0.07 mm (0.003 in)

If the calculated clearance is more than the service limit, replace the piston pin and recheck the clearance.

If the clearance is still more than the service limit with the new piston pin, replace the piston.

PISTON RING SIDE CLEARANCE

Measure the clearance between each piston ring and ring groove of the piston using a thickness gauge.

STANDARD:

Top: 0.035 – 0.070 mm (0.0014 – 0.0028 in)

Second: 0.045 – 0.080 mm (0.0018 – 0.0032 in)

SERVICE LIMIT:

Top: 0.20 mm (0.008 in)

Second: 0.20 mm (0.008 in)

If any measurement is more than the service limit, inspect the piston ring width.

If the piston ring width is normal, replace the piston and reinspect the clearance.

If necessary, replace the piston rings (top, second, oil) respectively and reinspect the clearance.

If any measurement is still more than the service limit with the new piston rings, replace the piston.

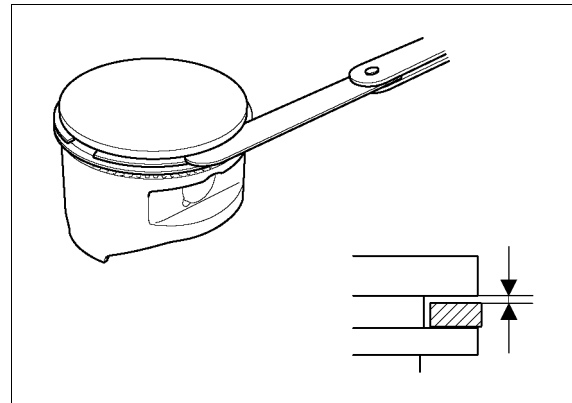

PISTON RING WIDTH

Measure each piston ring width.

STANDARD:

Top: 0.970 – 0.995 mm (0.0382 – 0.0392 in)

Second: 0.940 – 0.960 mm (0.0370 – 0.0378 in)

SERVICE LIMIT:

Top: 0.968 mm (0.0381 in)

Second: 0.938 mm (0.0369 in)

If any measurement is less than the service limit, replace the piston rings (top, second, oil) respectively.

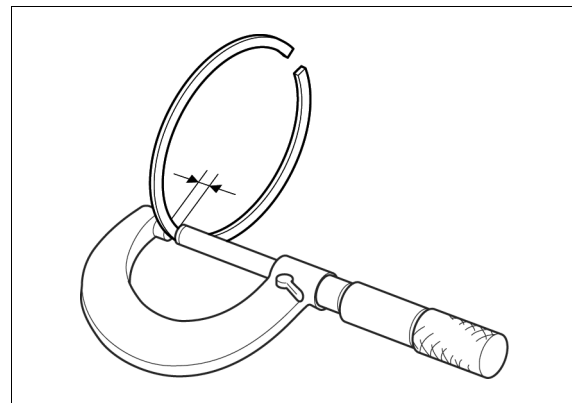

CYLINDER BLOCK

PISTON RING END GAP

Before inspection, check whether the cylinder sleeve I.D. is within the specification (page 13-6).

Measure each piston ring [1] end gap using a thickness gauge.

STANDARD:

Top: 0.15 – 0.35 mm (0.006 – 0.014 in)
Second: 0.15 – 0.45 mm (0.006 – 0.018 in)
Oil (side rail): 0.10 – 0.70 mm (0.004 – 0.028 in)

SERVICE LIMIT:

Top: 1.0 mm (0.04 in)
Second: 1.0 mm (0.04 in)
Oil (side rail): 2.0 mm (0.08 in)

If any measurement is more than the service limit, replace the piston rings (top, second, oil) respectively.

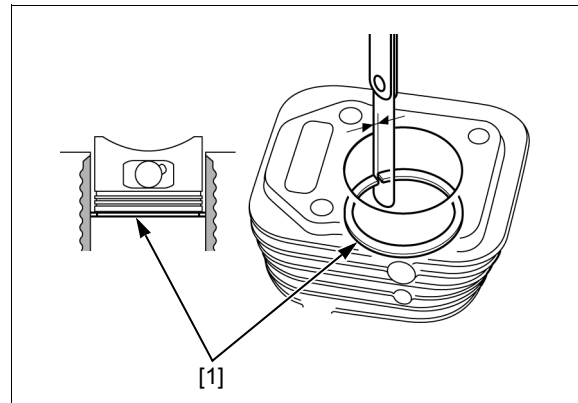

CONNECTING ROD BIG END SIDE CLEARANCE

Measure the clearance between the connecting rod big end and crankshaft using a thickness gauge.

STANDARD: 0.10 – 0.40 mm (0.004 – 0.016 in)
SERVICE LIMIT: 0.60 mm (0.024 in)

If the measurement is more than the service limit, replace the connecting rod (page 13-5) and recheck the clearance.

If the clearance is still more than the service limit with the new connecting rod, replace the crankshaft.



CONNECTING ROD BIG END OIL CLEARANCE

Clean all oil from the crankpin and connecting rod big end surface.

Place a piece of plastigauge on the crankpin, install the connecting rod upper end and the connecting rod lower end, and tighten the connecting rod bolts [1] to the specified torque.

TORQUE: 5.0 N·m (0.5 kgf·m, 3.7 lbf·ft)

NOTE:

- Do not rotate the crankshaft while the plastigauge is in place.

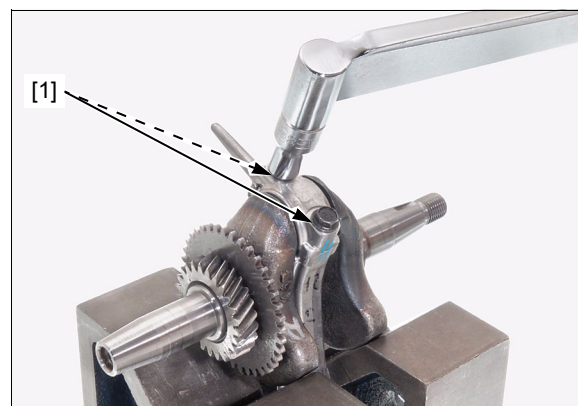

CYLINDER BLOCK

Remove the connecting rod and measure the compressed width of the plastigauge [1] using the scale printed on the bag [2] of the plastigauge.

STANDARD: 0.036 – 0.057 mm (0.0014 – 0.0022 in)

SERVICE LIMIT: 0.10 mm (0.004 in)

If the clearance is more than the service limit, inspect the connecting rod big end I.D. and the crankpin O.D.

If necessary, replace the part that is not within the service limit and reinspect the clearance.

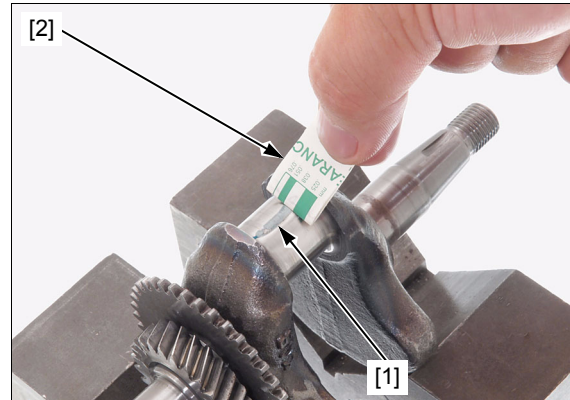

CONNECTING ROD SMALL END I.D./ BIG END I.D.

Measure the connecting rod small end I.D.

STANDARD: 12.005 – 12.020 mm (0.4726 – 0.4732 in)

SERVICE LIMIT: 12.07 mm (0.4752 in)

If the measurement is more than the service limit, replace the connecting rod.

Check the piston pin O.D. (page 13-7).

Set the connecting rod lower end to the connecting rod upper end and tighten the connecting rod bolts to the specified torque.

TORQUE: 5.0 N·m (0.5 kgf·m, 3.7 lbf·ft)

Measure the connecting rod big end I.D.

STANDARD: 20.016 – 20.027 mm (0.7880 – 0.7885 in)

SERVICE LIMIT: 20.07 mm (0.790 in)

If the measurement is more than the service limit, replace the connecting rod.

Check the crankpin O.D. (page 13-10).

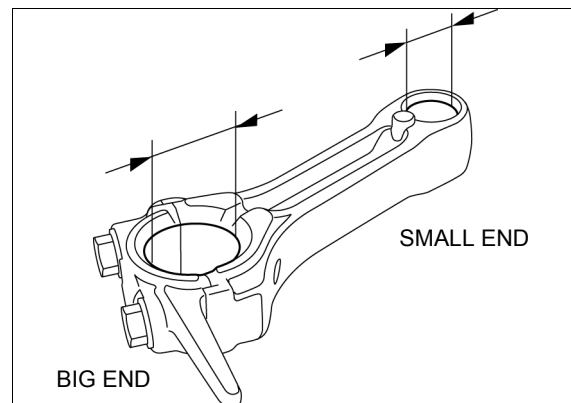

CRANKPIN O.D.

Measure the crankpin O.D. of the crankshaft.

STANDARD: 19.970 – 19.980 mm (0.7862 – 0.7866 in)

SERVICE LIMIT: 19.93 mm (0.785 in)

If the measurement is less than the service limit, replace the crankshaft.

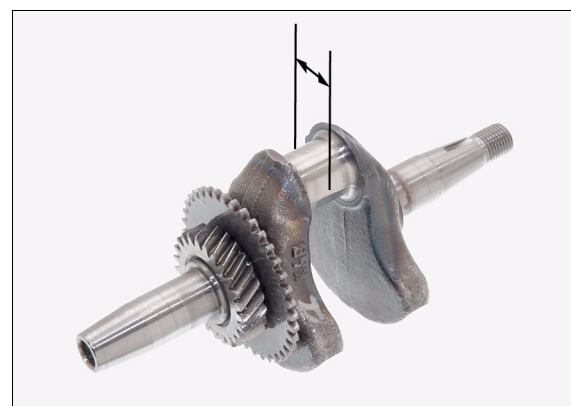

CYLINDER BLOCK**CAMSHAFT CAM HEIGHT**

Measure the cam height of the camshaft.

STANDARD:

IN: 19.599 – 19.999 mm (0.7716 – 0.7874 in)

EX: 19.641 – 20.041 mm (0.7733 – 0.7890 in)

SERVICE LIMIT:

IN: 19.40 mm (0.764 in)

EX: 19.44 mm (0.765 in)

If the measurement is less than the service limit, replace the camshaft.

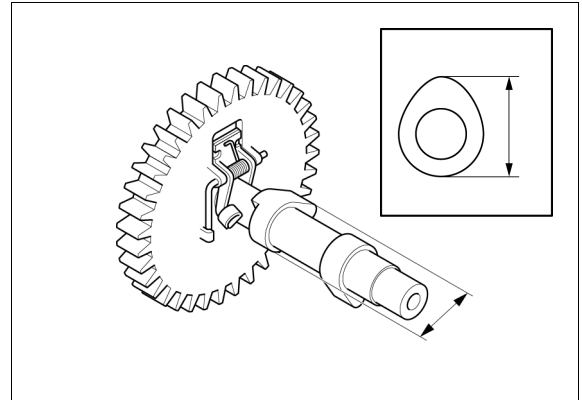
**CAMSHAFT O.D.**

Measure the journal O.D. of the camshaft.

STANDARD: 9.972 – 9.987 mm (0.3926 – 0.3932 in)

SERVICE LIMIT: 9.95 mm (0.392 in)

If the measurement is less than the service limit, replace the camshaft.

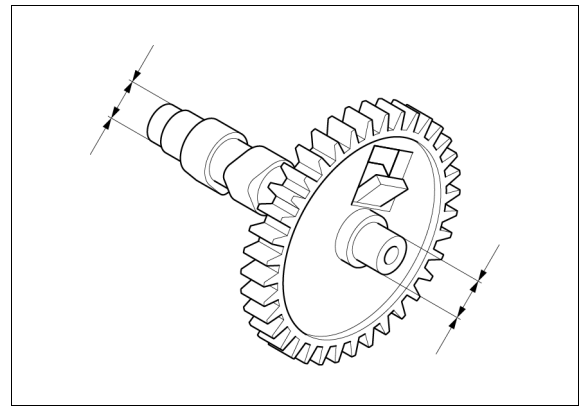
**DECOMPRESSOR WEIGHT**

Check that the decompressor weight [1] moves smoothly.

If the decompressor weight does not move correctly, replace the camshaft.

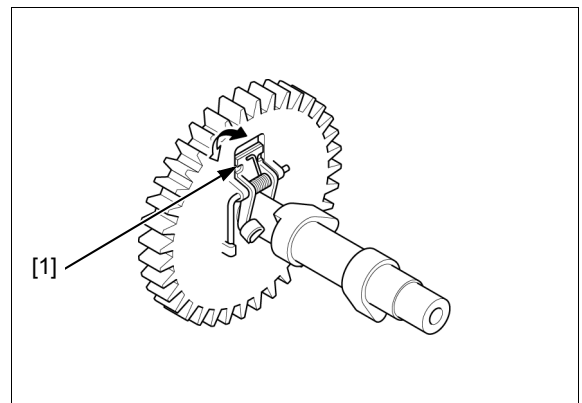
**CRANKSHAFT BEARING**

Turn the inner race of the bearing with your finger and check for play.

Replace the bearing if it is noisy or has excessive play.

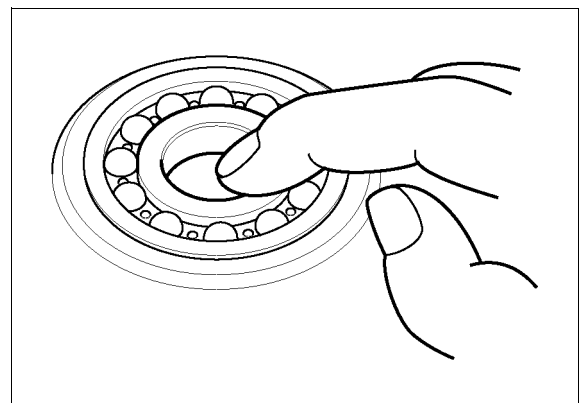

CYLINDER BLOCK

CRANKSHAFT BEARING/OIL SEAL REPLACEMENT

CRANKSHAFT BEARING

CRANKCASE COVER SIDE

Remove the oil seal and drive the crankshaft bearing.

Drive a new crankshaft bearing [1] until it is fully seated on the end.

TOOLS:

Attachment, 37 × 40mm [2]

07746-0010200

Pilot, 17 mm [3]

07746-0040400

Driver [4]

07749-0010000

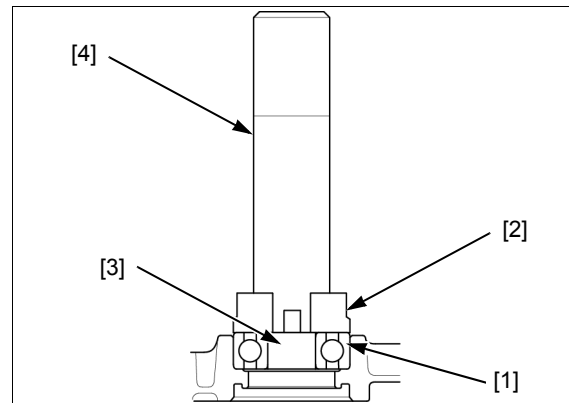

CRANKSHAFT SIDE

Install the nut (12 mm) [1] on the crankshaft.

Remove the crankshaft bearing [2] from the crankshaft by using the bearing puller [3] and the hydraulic press [4].

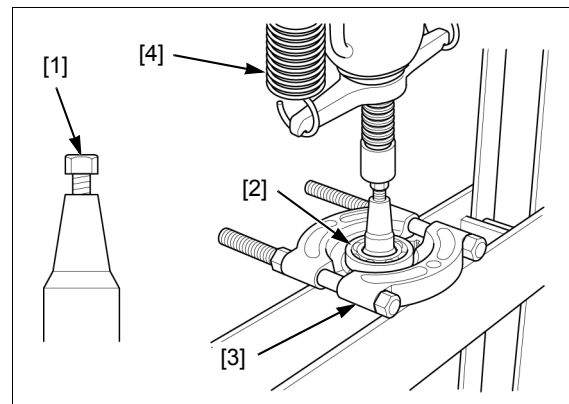

Install the crankshaft [1] on the crankshaft by using the hydraulic press [2].

TOOLS:

Attachment 17mm [3]

07746-0020300

Driver, 22 mm I.D. [4]

07746-0020100

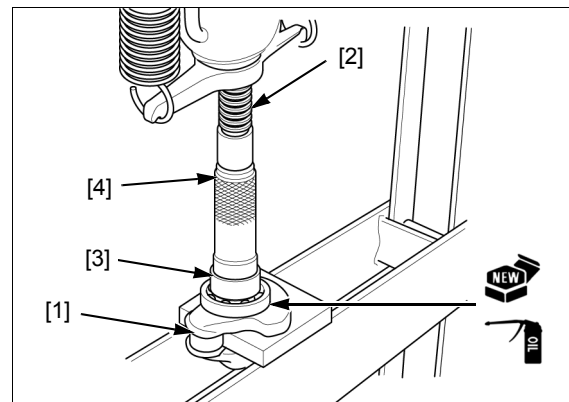

CRANKSHAFT OIL SEAL

CRANKCASE COVER SIDE/CYLINDER BLOCK SIDE

Remove the oil seal.

Drive a new oil seal [1] in the position as shown.

INSTALLATION HEIGHT: 0.5 - 1.5 mm
(0.02 - 0.06 in)

TOOLS:

Attachment, 27 × 30mm [2]

07946-1870100

Pilot, 17 mm [3]

07746-0040400

Driver [4]

07749-0010000

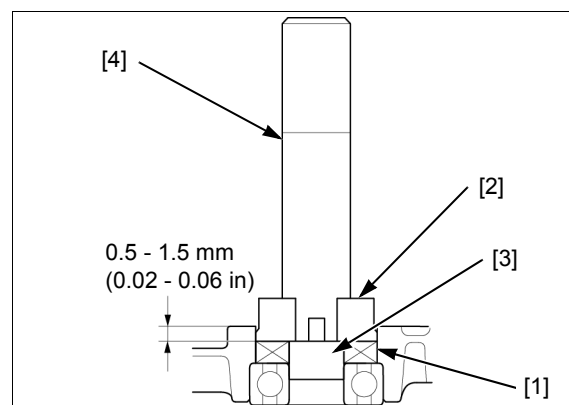

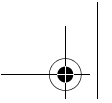

14. HANDLE

**HANDLE ASSEMBLY REMOVAL/
INSTALLATION**.....14-2

**THROTTLE CABLE REMOVAL/
INSTALLATION**.....14-2

**CLUTCH CABLE REMOVAL/
INSTALLATION**.....14-3

HANDLE DISASSEMBLY/ASSEMBLY..... 14-4

**CLUTCH LEVER DISASSEMBLY/
ASSEMBLY**..... 14-5

**THROTTLE LEVER DISASSEMBLY/
ASSEMBLY**..... 14-6

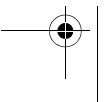
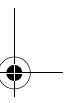
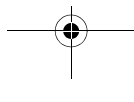
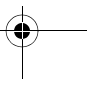
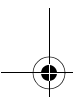

HANDLE

HANDLE ASSEMBLY REMOVAL/INSTALLATION

NOTE:

- Before installation, route the wire harness properly (page 2-7).

Disassemble the following:

- Belt cover (page 11-2)
- Air cleaner (page 5-4)
- Fuel tank (page 5-3)

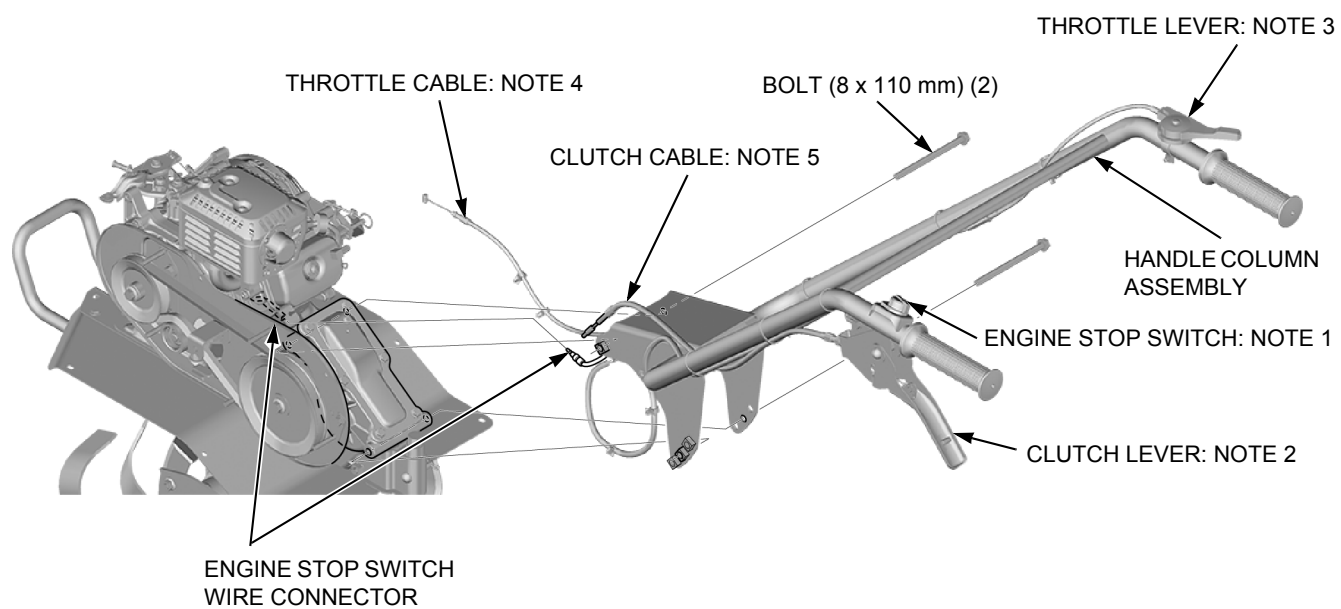

NOTE 1	ENGINE STOP SWITCH REMOVAL/INSTALLATION	page 7-8
NOTE 2	CLUTCH LEVER DISASSEMBLY/ASSEMBLY	page 14-5
NOTE 3	THROTTLE LEVER DISASSEMBLY/ASSEMBLY	page 14-6
NOTE 4	THROTTLE CABLE REMOVAL/INSTALLATION	page 14-2
NOTE 5	CLUTCH CABLE REMOVAL/INSTALLATION	page 14-3

THROTTLE CABLE REMOVAL/INSTALLATION

Move the throttle lever to the "LOW" position and disconnect the throttle cable [1] from the control lever [2].

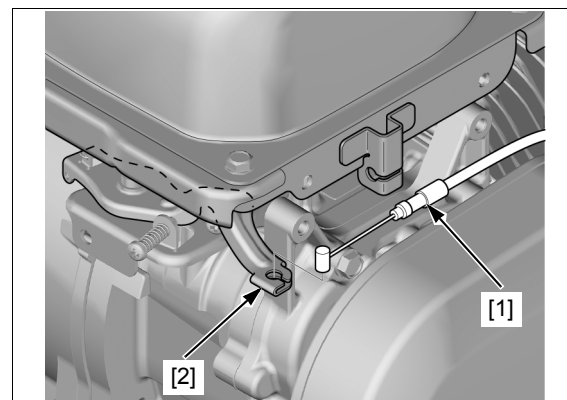

HANDLE

CLUTCH CABLE REMOVAL/INSTALLATION

Remove the inner belt cover if necessary (page 11-2).

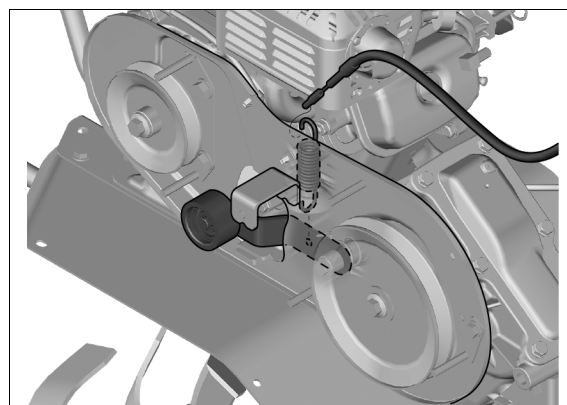

HANDLE

HANDLE DISASSEMBLY/ASSEMBLY

Remove the handle assembly (page 14-2).

Disassemble the following:

- Engine stop switch (page 7-8)
- Clutch lever (page 14-5)
- Throttle lever (page 14-6)

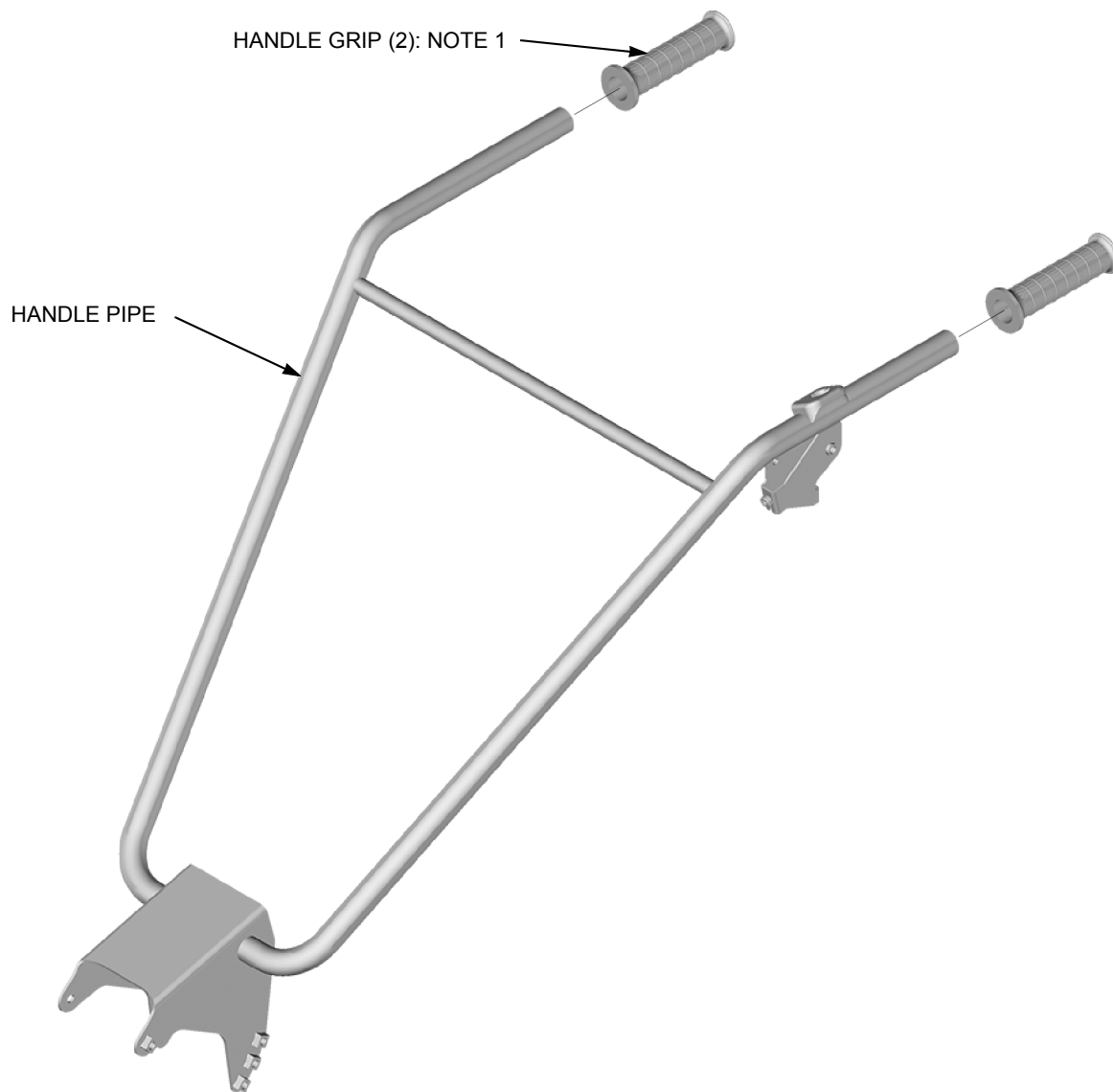

NOTE 1	Apply CEMEDINE #540 or equivalent to the inside.	-
--------	--	---

CLUTCH LEVER DISASSEMBLY/ASSEMBLY

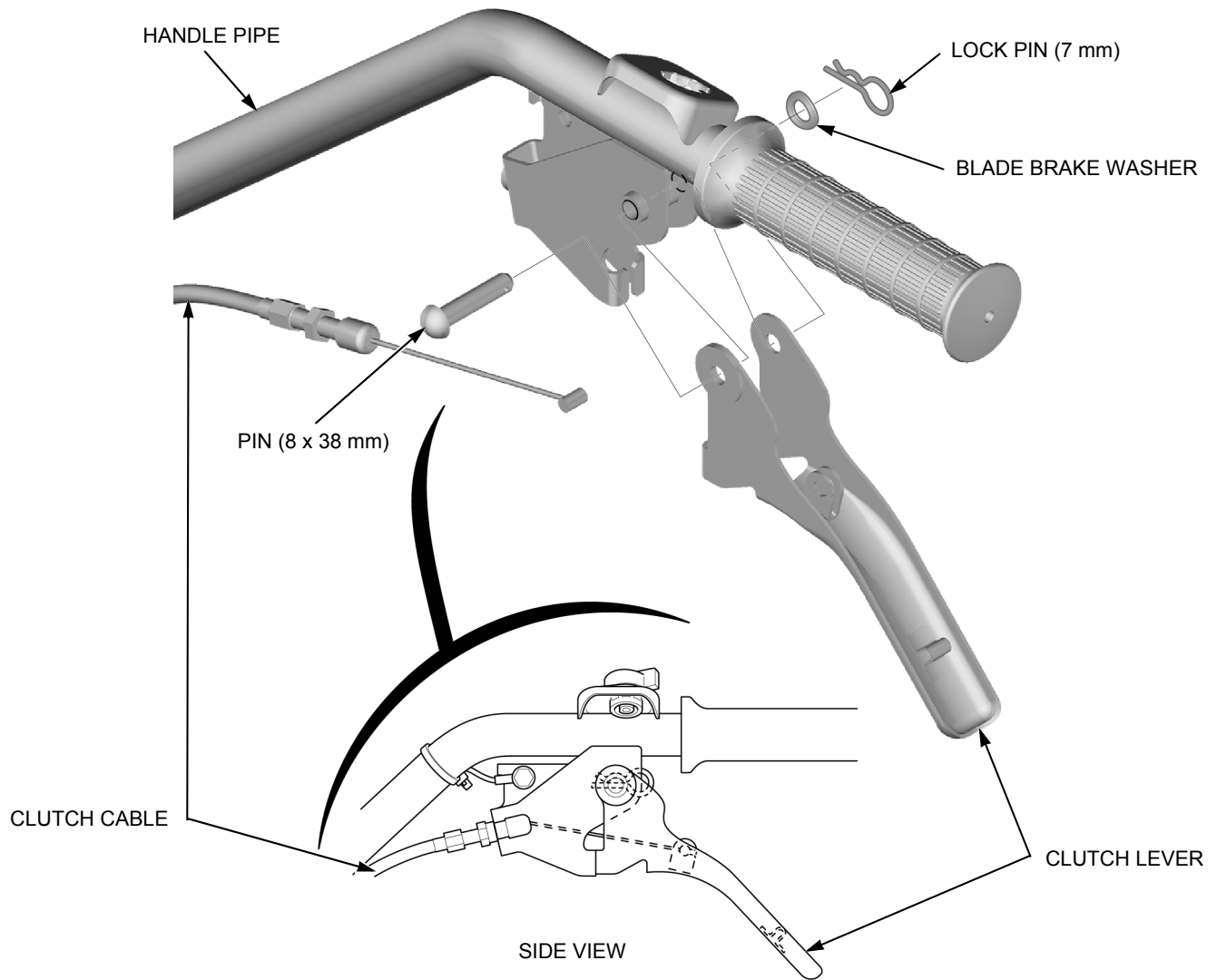

HANDLE

THROTTLE LEVER DISASSEMBLY/ASSEMBLY

After reassembly, perform the "THROTTLE CABLE CHECK/ADJUSTMENT" (page 3-10).

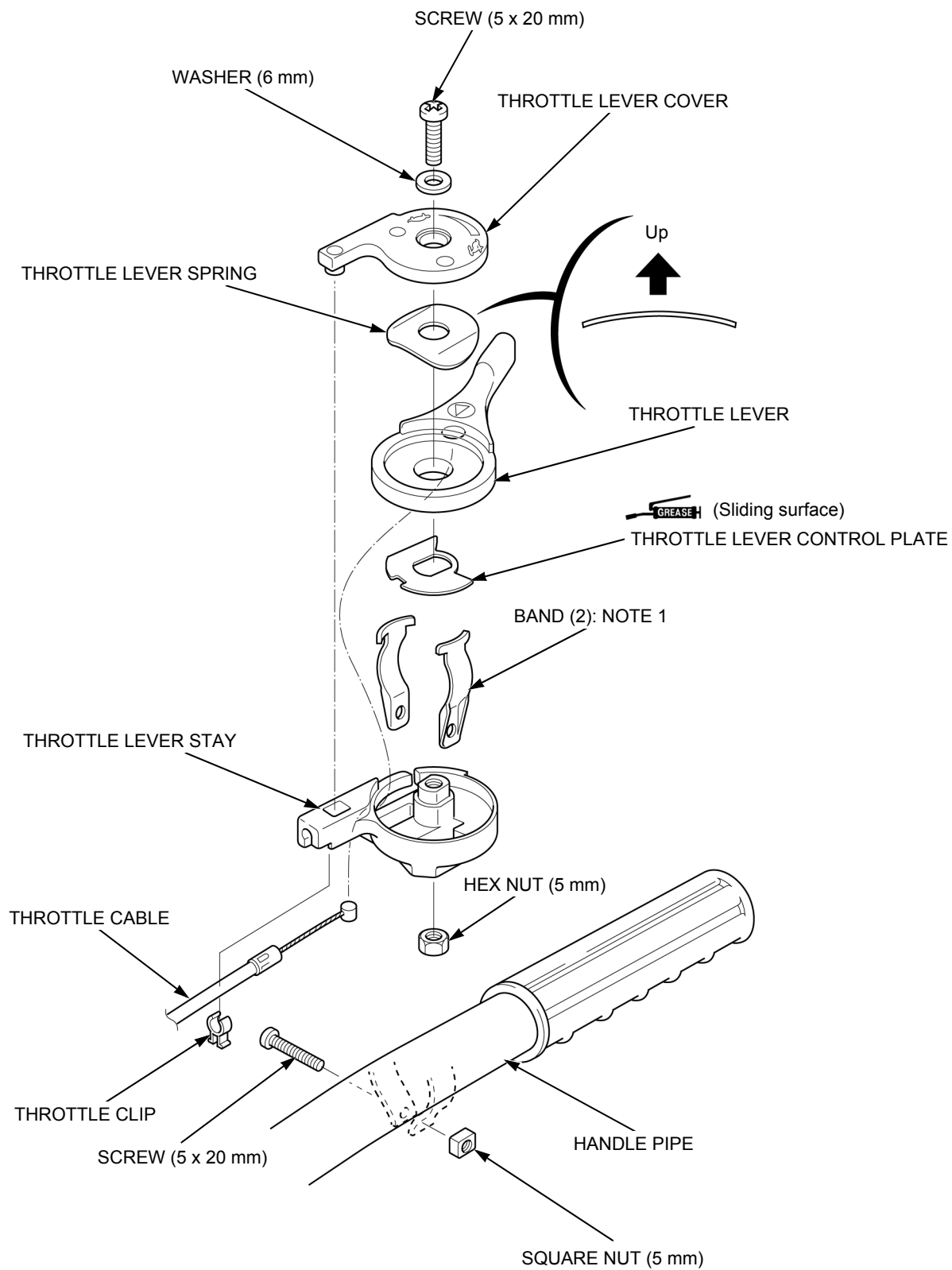

NOTE 1 Before reassembly, position the bands to the specified range.

page 2-7

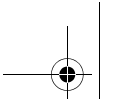

15. ROTOR/TRANSMISSION

TOOLS.....	15-2	ROTOR ASSEMBLY CHECK (IN TYPE)....	15-8
ROTOR REMOVAL/INSTALLATION (IN TYPE).....	15-3	TRANSMISSION REMOVAL/ INSTALLATION	15-9
ROTOR DISASSEMBLY/ASSEMBLY (IN TYPE).....	15-4	TRANSMISSION DISASSEMBLY/ ASSEMBLY	15-10
ROTOR DISASSEMBLY/ASSEMBLY (T, KW TYPE)	15-6		

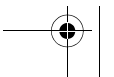
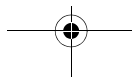
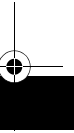
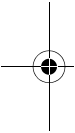

ROTOR/TRANSMISSION

TOOLS

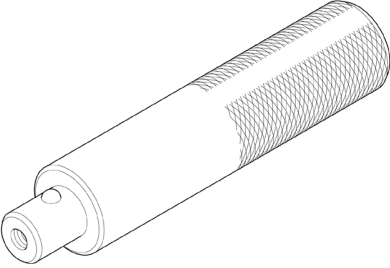
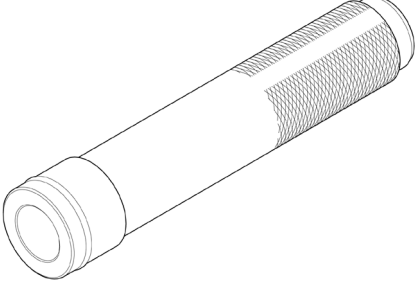
<p>Pilot, 28 mm 07746-0041100</p>  A small cylindrical pilot tool with a threaded top section.	<p>Driver 07749-0010000</p>  A long cylindrical driver tool with a textured grip section and a small protrusion at one end.	<p>Driver, 22 mm I.D. 07746-0020100</p>  A long cylindrical driver tool with a textured grip section and a larger protrusion at one end.
---	---	---

ROTOR/TRANSMISSION

ROTOR REMOVAL/INSTALLATION (IN TYPE)

NOTE:

- The right side rotors and left side rotors can be removed in the same manner.
- After installation, make sure that the right and left rotors are symmetry (page 15-8).

L. ROTOR shown:

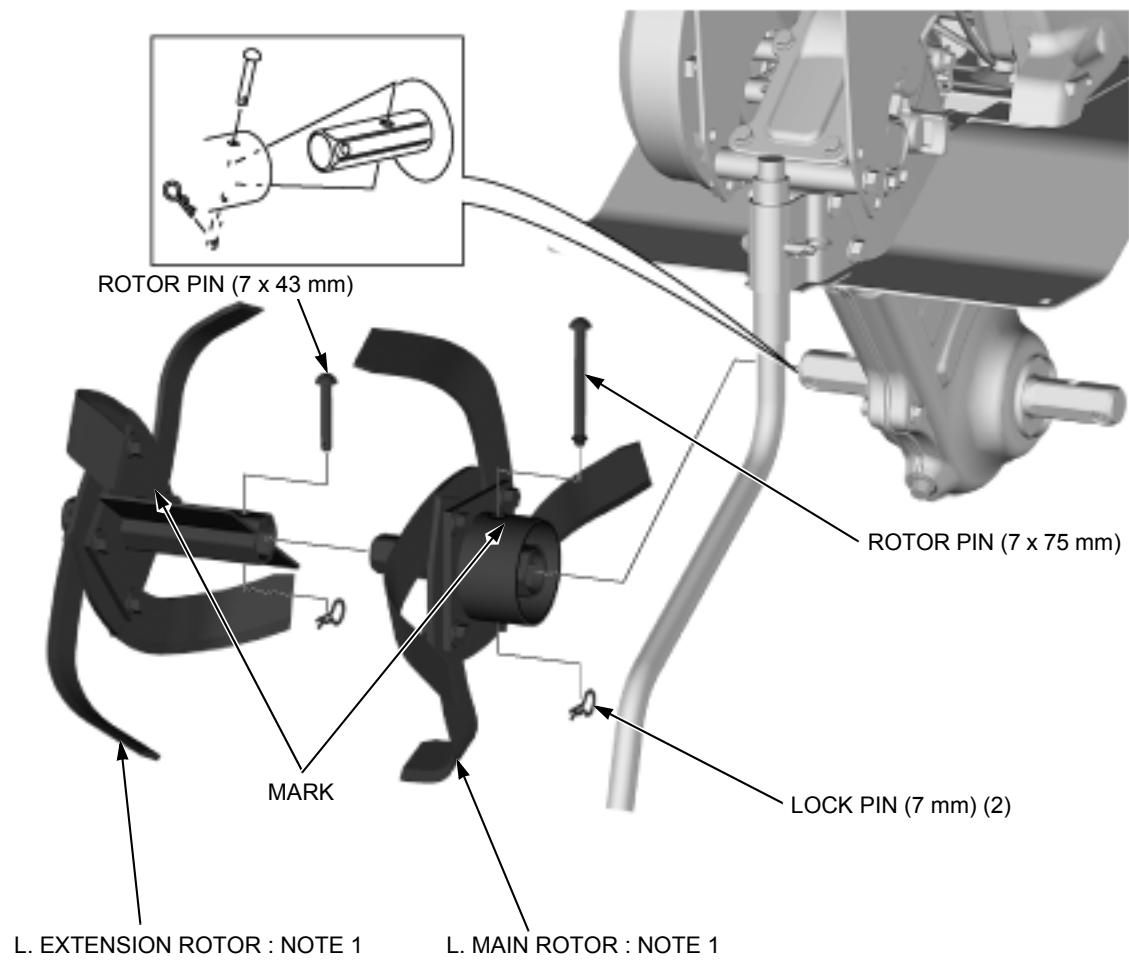

NOTE 1	ROTOR DISASSEMBLY/ASSEMBLY (IN TYPE)	page 15-4
--------	--------------------------------------	-----------

ROTOR/TRANSMISSION

ROTOR DISASSEMBLY/ASSEMBLY (IN TYPE)

L. ROTOR

NOTE:

- When reassembling whole parts, assemble the tines with its identification marks ("A" and "B") facing outward.
- Tillage width can be adjusted into 550 mm by interchanging a L rotor tine and a R rotor tine.

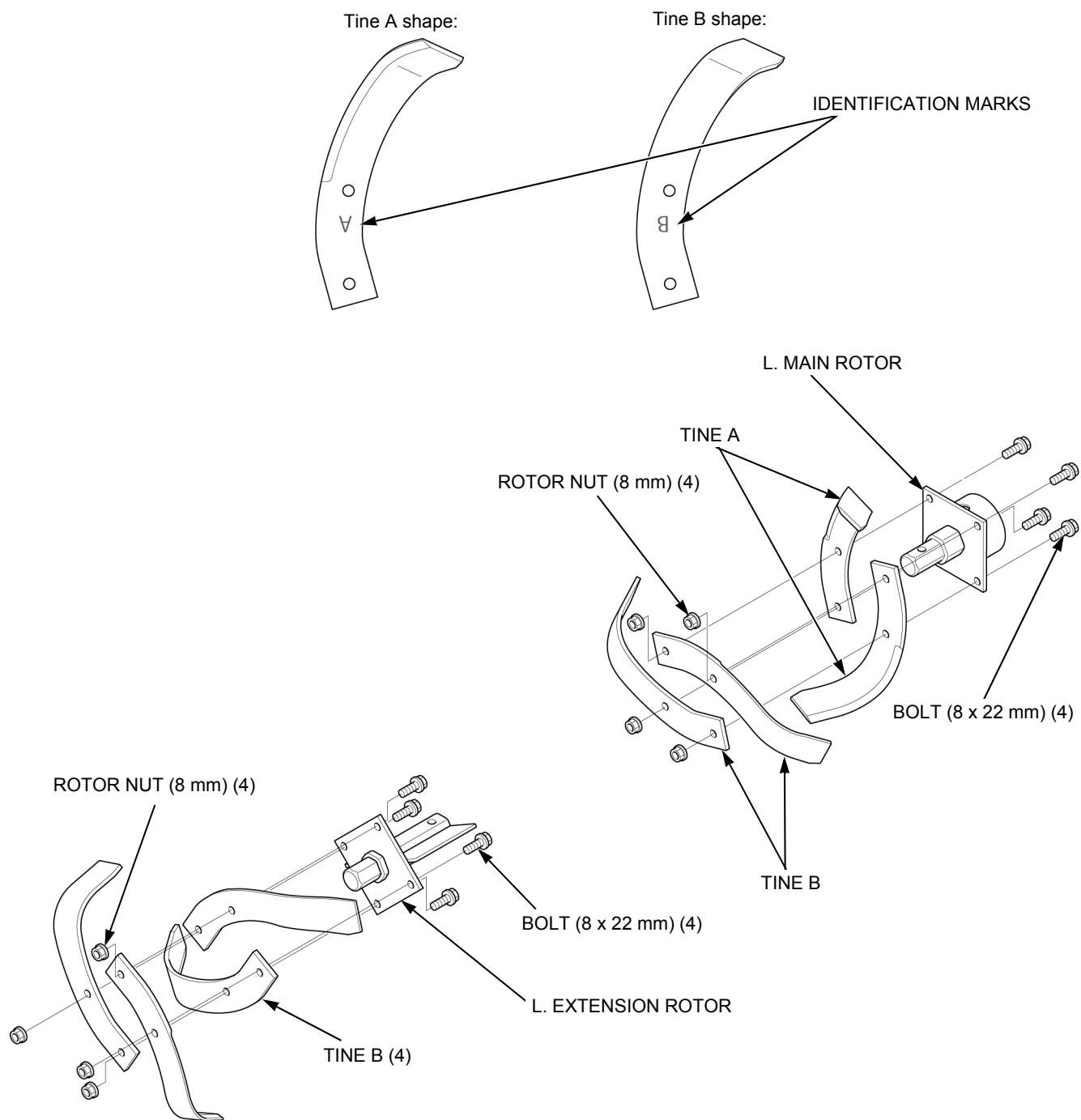

ROTOR/TRANSMISSION

R. ROTOR

NOTE:

- When reassembling whole parts, assemble the tines with its identification marks ("A" and "B") facing inward.
- Tillage width can be adjusted into 550 mm by interchanging a L rotor tine and a R rotor tine.

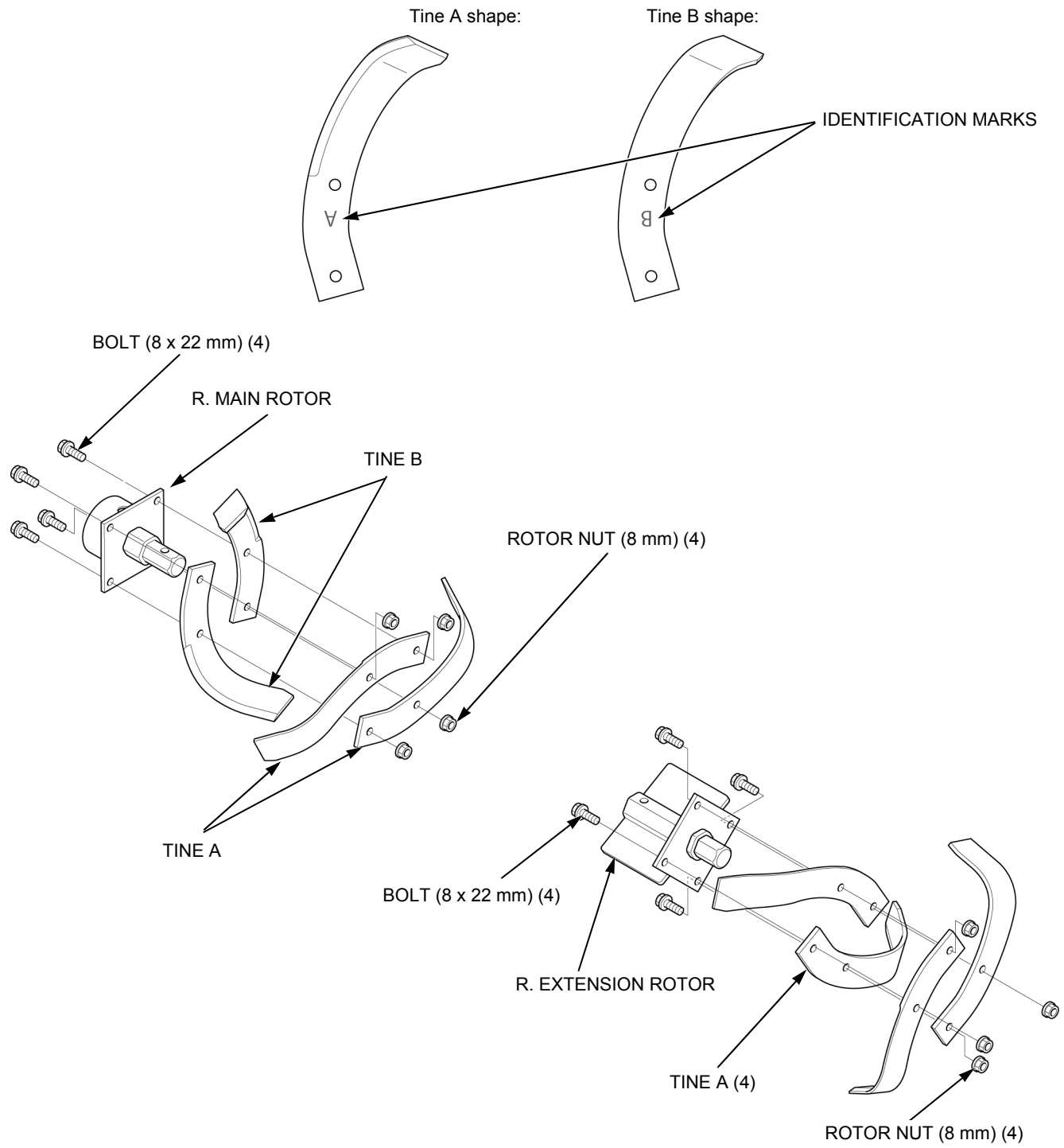

ROTOR/TRANSMISSION

ROTOR DISASSEMBLY/ASSEMBLY (T, KW TYPE)

L. ROTOR

NOTE:

- When reassembling whole parts assemble the tines with its identification marks ("A" and "B") facing outward.
- The tillage width set 550 mm in IN types is the same as the tillage width of KW type.

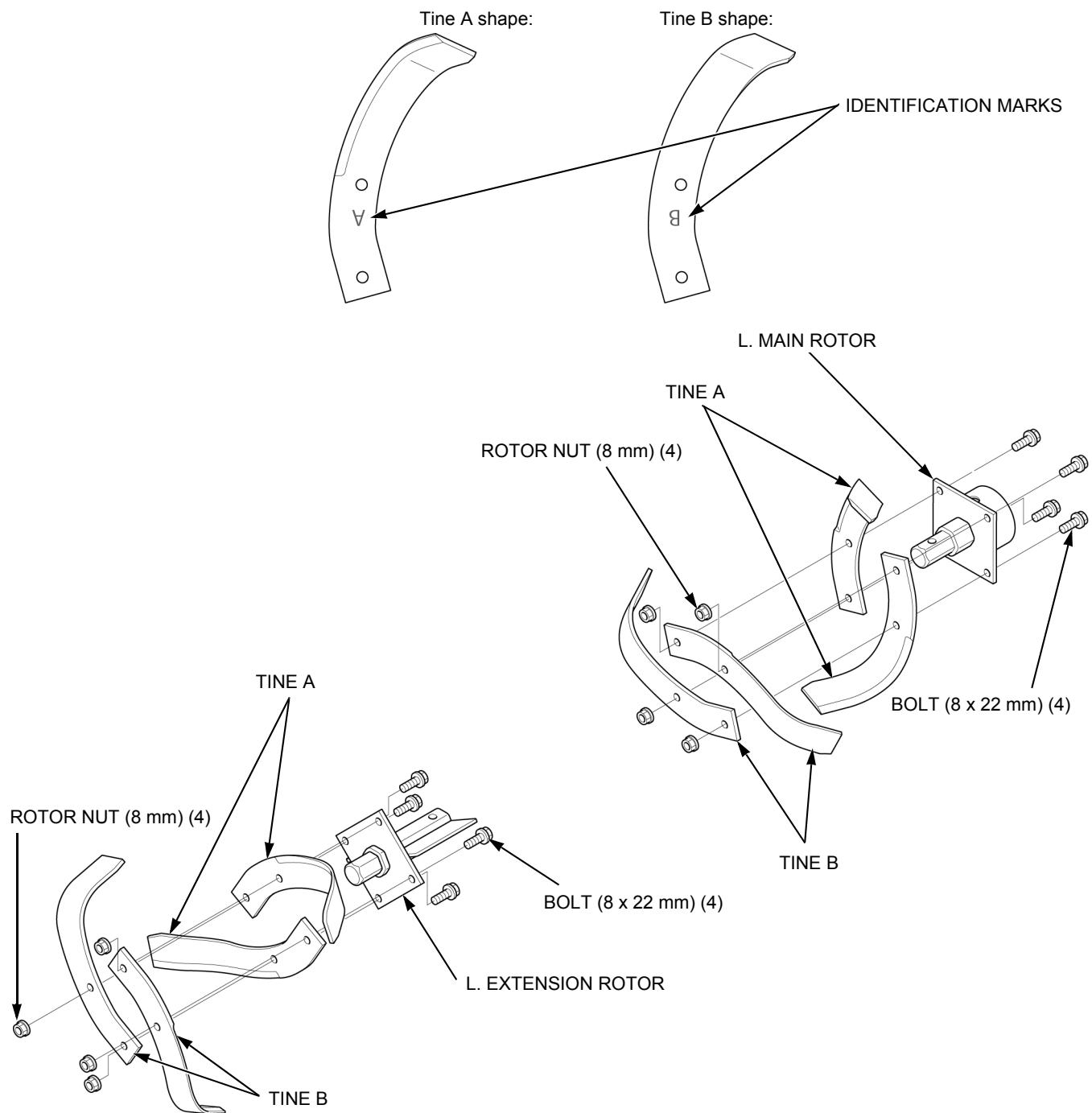

ROTOR/TRANSMISSION

R. ROTOR

NOTE:

- When reassembling whole parts, assemble the tines with its identification marks ("A" and "B") facing inward.
- The tillage width set 550 mm in IN types is the same as the tillage width of KW type.

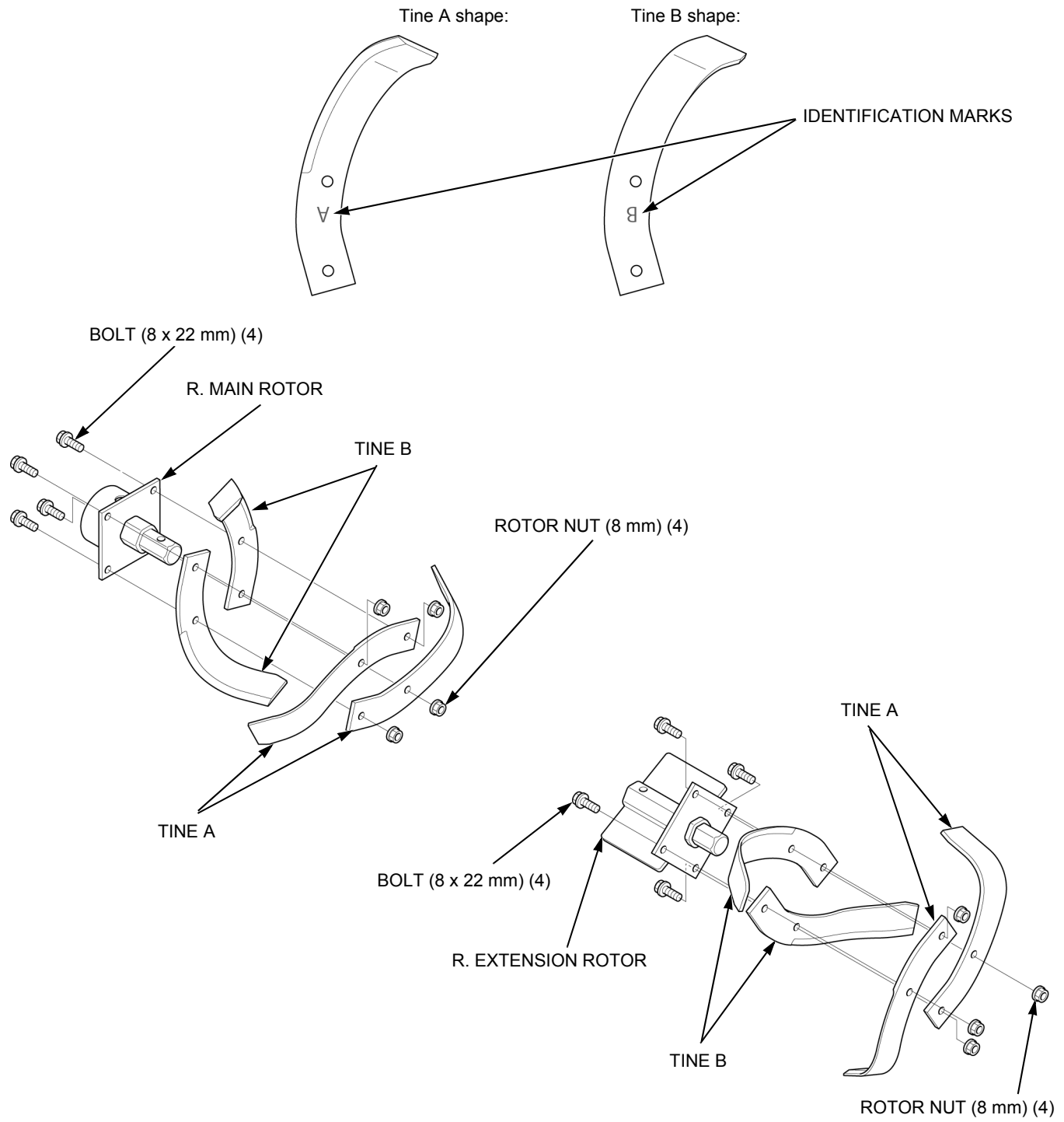

ROTOR/TRANSMISSION

ROTOR ASSEMBLY CHECK (IN TYPE)

Check that the tines are assembled properly as shown.

NOTE:

- The right rotors and left rotors are symmetry.

R. MAIN ROTOR (Outside view):

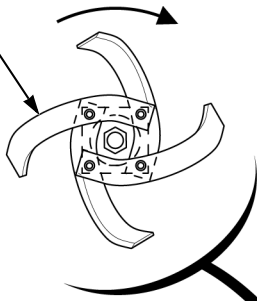

R. EXTENSION ROTOR (Outside view):

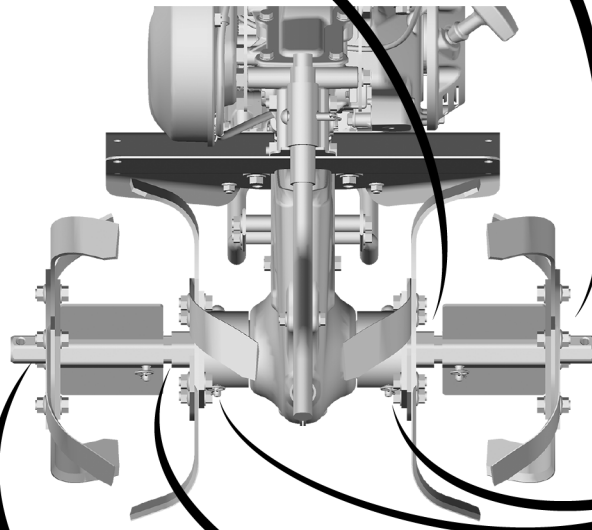
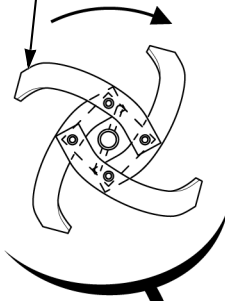

FRONT

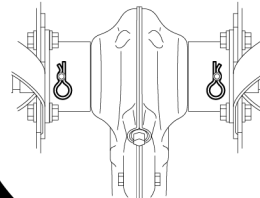

L. EXTENSION ROTOR (Outside view):

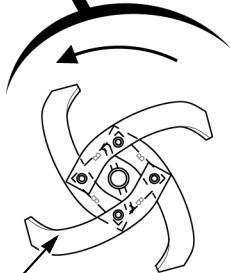

L. MAIN ROTOR (Outside view):

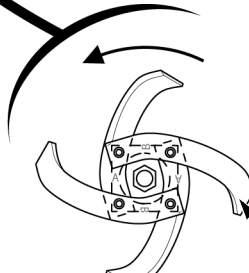

ROTOR/TRANSMISSION

TRANSMISSION REMOVAL/INSTALLATION

Remove the following:

- Handle assembly (page 14-2)
- Engine (page 10-2)
- Rotor (IN TYPE) (page 15-3)

NOTE:

- After installation, check the transmission oil level if the transmission is disassembled (page 3-6).

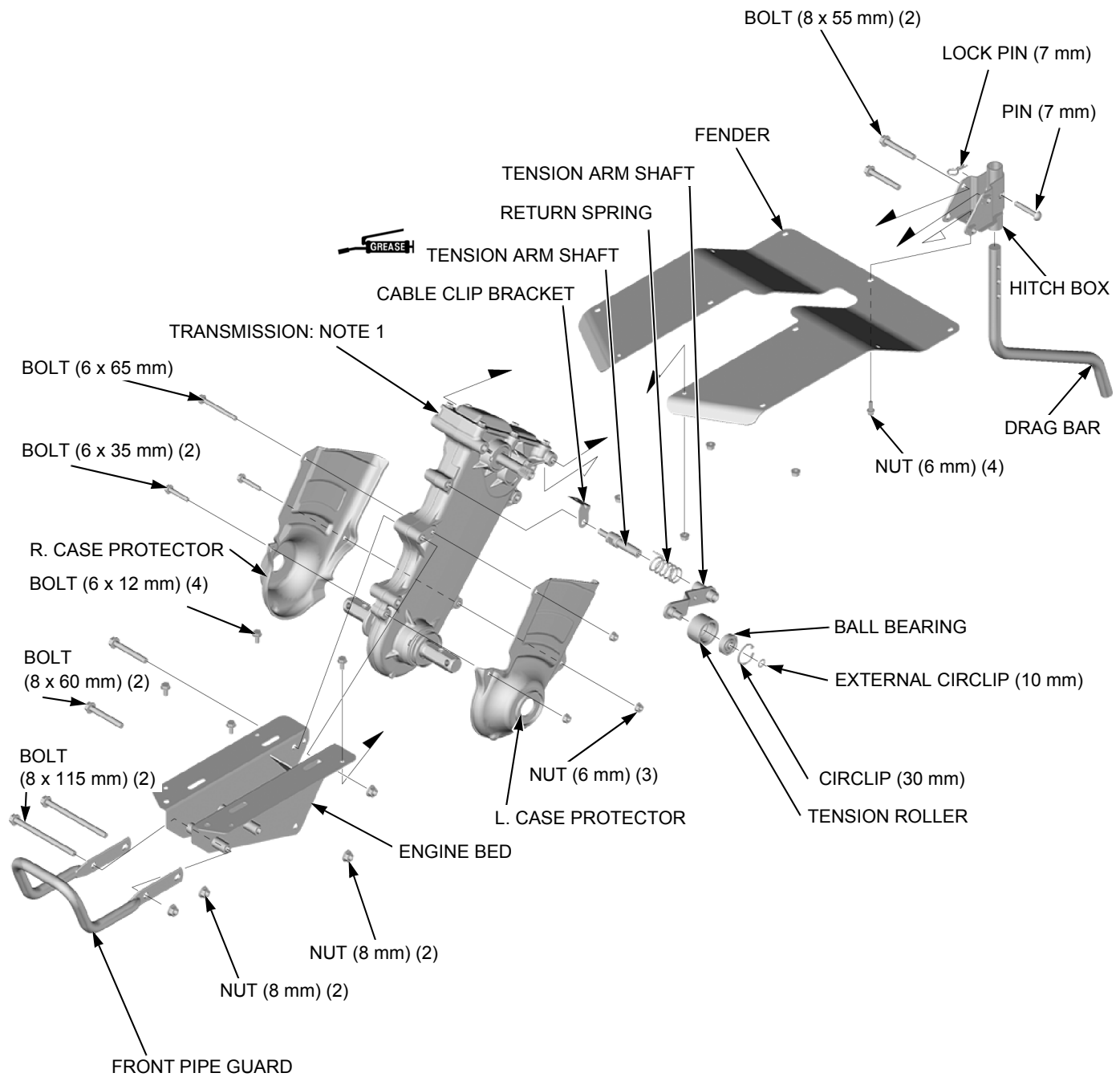

NOTE 1 TRANSMISSION DISASSEMBLY/ASSEMBLY

page 15-10

ROTOR/TRANSMISSION

TRANSMISSION DISASSEMBLY/ASSEMBLY

NOTE:

- The transmission case cannot be separated. For ease of transmission disassembly/reassembly, turn the transmission case as shown in the figure.
- When assembling the transmission, position all gears in the case and then insert the shafts.
- The gears on the final shaft, countershaft and driven sprocket can be removed without removing the input shaft.

Remove the transmission (page 15-9).

Place a suitable counter.

Remove the transmission top cover and drain the transmission oil from it.

After assembly, fill the recommended transmission oil (page 15-12).

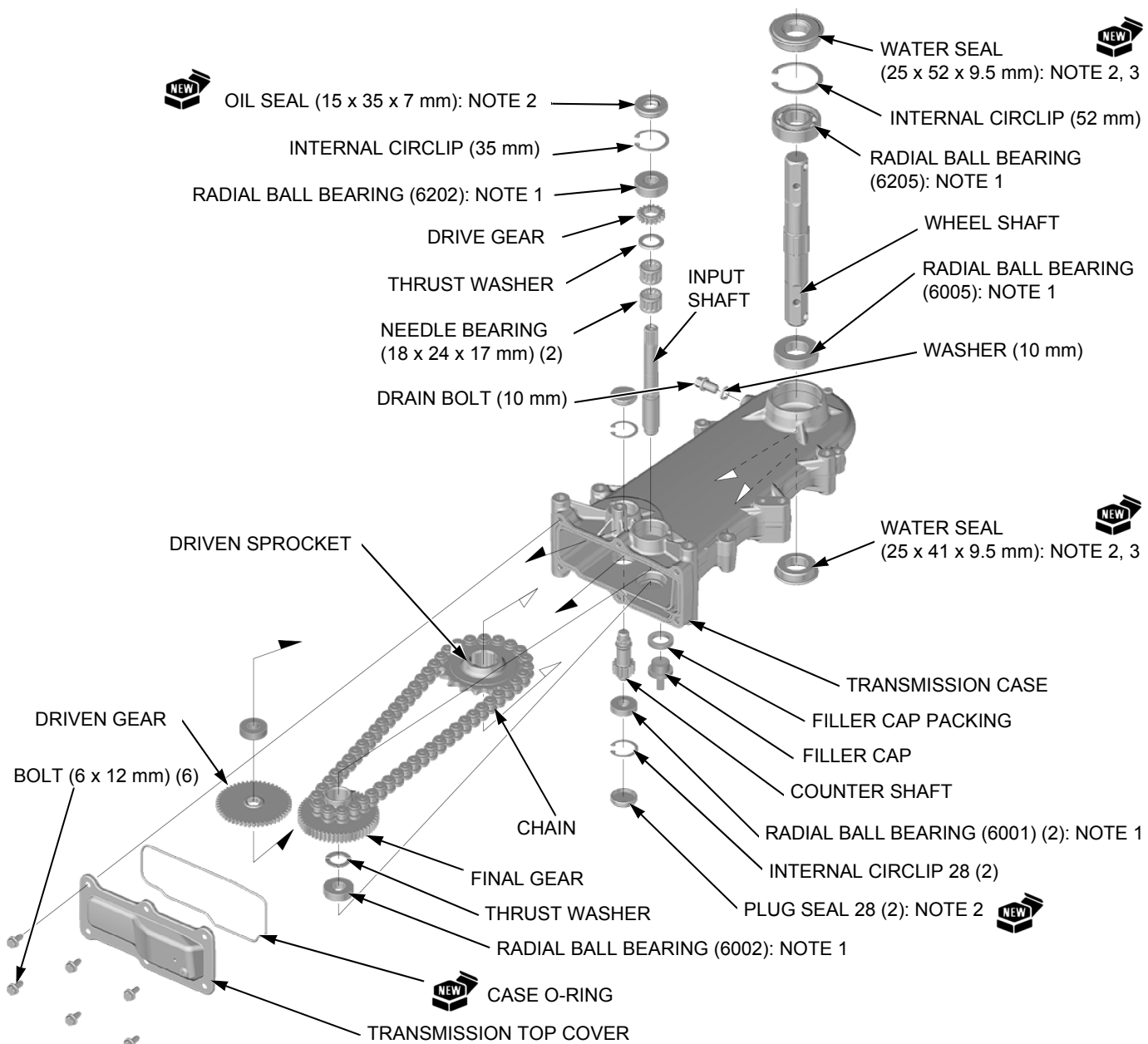

NOTE 1	RADIAL BALL BEARING INSPECTION	page 15-11
NOTE 2	PLUG SEAL/OIL SEAL/WATER SEAL INSTALLATION	page 15-11
NOTE 3	When disassembling the parts, take care not to damage the transmission case and wheel shaft.	-

ROTOR/TRANSMISSION

RADIAL BALL BEARING INSPECTION

Clean the bearing with solvent and dry it thoroughly.

Turn the inner race or outer race of the radial ball bearing with your finger and check for play.

If it is noisy or has excessive play, replace the radial ball bearing (page 15-10).

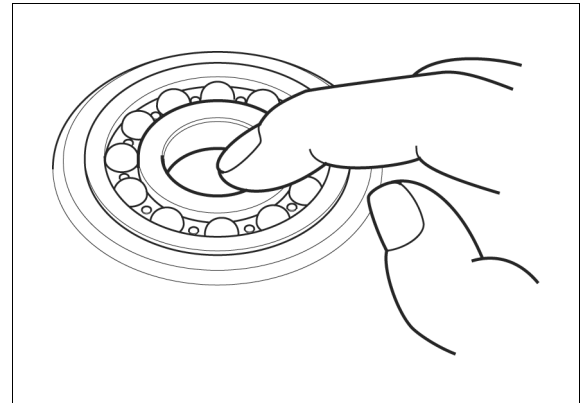

PLUG SEAL/OIL SEAL/WATER SEAL INSTALLATION

PLUG SEAL (28 mm)

Drive a new plug seal (28 mm) [1] from outside until it is flush with the transmission case surface by using the special tools.

TOOLS:

Pilot, 28 mm [2]

Driver [3]

07746-0041100

07749-0010000

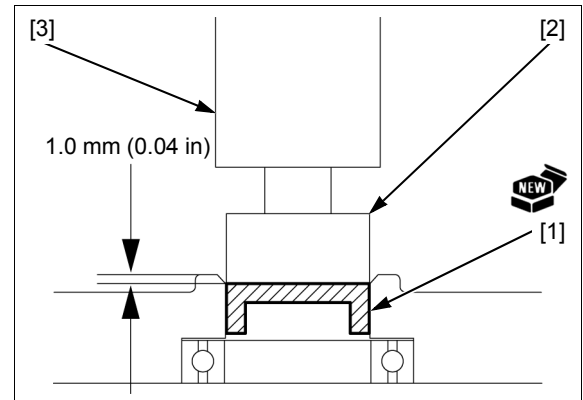

OIL SEAL (15 x 35 x 7 mm)

Drive a new oil seal (15 x 35 x 7 mm) [1] from outside until it is flush with the transmission case surface by using the special tools.

TOOL:

Driver, 22 mm I.D. [2]

07746-0020100

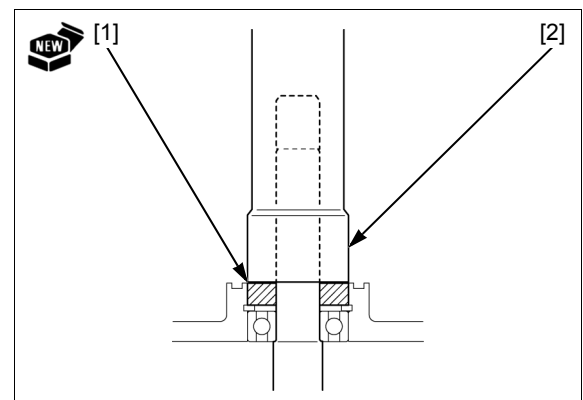

ROTOR/TRANSMISSION

WATER SEAL (25 x 52 x 9.5 mm)/(25 x 41 x 9.5 mm)

Install a new water seal (25 x 52 x 9.5 mm) [1]/water seal (25 x 41 x 9.5 mm) [2] until it is fully seated by using the special tool and hydraulic press.

TOOL:

Driver, 22 mm I.D. [3]

07746-0020100

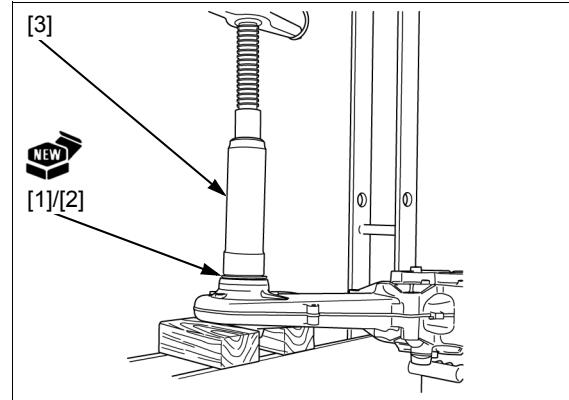

TRANSMISSION OIL FILLING

Fill the specified amount of recommended transmission oil into the transmission case.

RECOMMENDED TRANSMISSION OIL:

SAE 10W-30

API service classification SE or higher

TRANSMISSION OIL CAPACITY:

1.0 liter (1.1 US qt, 0.9 Imp qt)

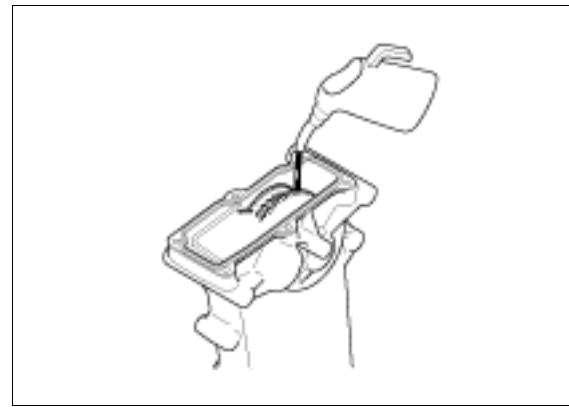

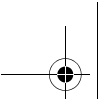

16. WHEEL/FRONT WEIGHT

WHEEL/FRONT WEIGHT/REMOVAL/
INSTALLATION16-2

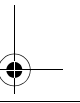
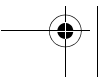
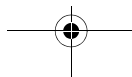
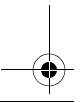
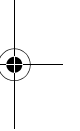
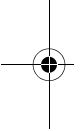

WHEEL/FRONT WEIGHT

WHEEL/FRONT WEIGHT/REMOVAL/INSTALLATION

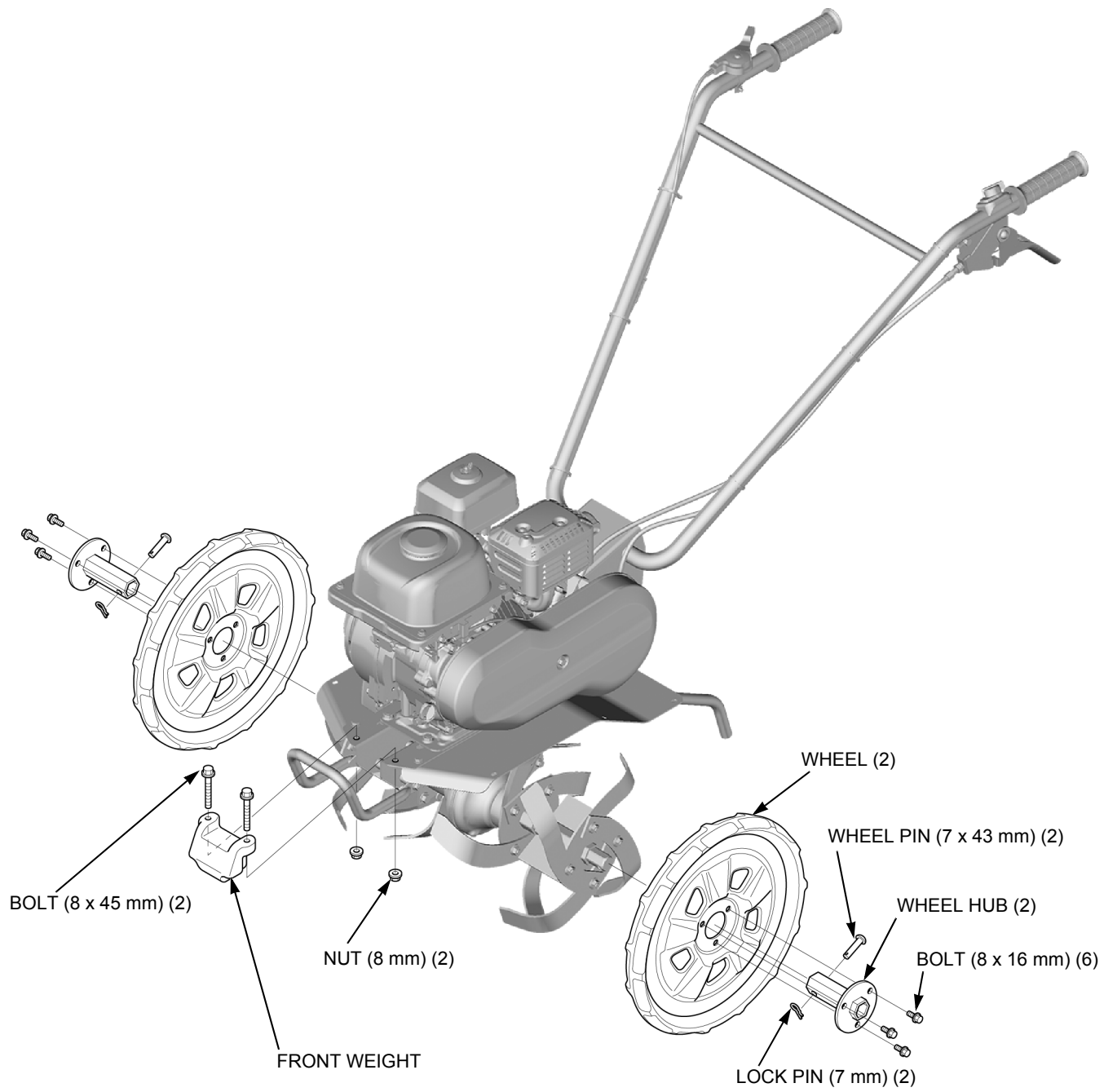

INDEX

AIR CLEANER CHECK/CLEANING/REPLACEMENT	3-5	HANDLE DISASSEMBLY/ASSEMBLY	14-4
AIR CLEANER REMOVAL/INSTALLATION	5-4	IGNITION COIL AIR GAP CHECK/ADJUSTMENT	7-6
BEFORE TROUBLESHOOTING		IGNITION COIL INSPECTION	7-6
IGNITION SYSTEM	7-2	IGNITION COIL REMOVAL/INSTALLATION	7-3
TROUBLESHOOTING	4-2	IGNITION SYSTEM TROUBLESHOOTING	7-2
BELT TENSION CHECK/ADJUSTMENT	3-11	LUBRICATION & SEAL POINT	2-4
BOLTS AND NUTS TIGHTNESS	3-6	MAINTENANCE SCHEDULE	3-2
CABLE/HARNESS ROUTING	2-7	MAINTENANCE STANDARDS	2-2
CARBURETOR BODY CLEANING	5-8	MUFFLER REMOVAL/INSTALLATION	9-2
CARBURETOR DISASSEMBLY/ASSEMBLY	5-7	PISTON DISASSEMBLY/ASSEMBLY	13-5
CARBURETOR INSPECTION	5-8	PULLEY/V-BELT REMOVAL/INSTALLATION	11-2
CARBURETOR REMOVAL/INSTALLATION	5-5	RECOIL STARTER DISASSEMBLY/ASSEMBLY	8-3
CHOKE REPLACEMENT	5-9	RECOIL STARTER INSPECTION	8-6
CLUTCH CABLE CHECK/ADJUSTMENT	3-10	RECOIL STARTER REMOVAL/INSTALLATION	8-2
CLUTCH LEVER DISASSEMBLY/ASSEMBLY	14-5	ROTOR ASSEMBLY CHECK (IN TYPE)	15-8
COMBUSTION CHAMBER CLEANING	3-15	ROTOR DISASSEMBLY/ASSEMBLY (IN TYPE)	15-4
CONTROL BASE/GOVERNOR ARM REMOVAL/ INSTALLATION	6-2	ROTOR REMOVAL/INSTALLATION (IN TYPE)	15-3
CRANKCASE COVER/CRANKSHAFT/CAMSHAFT/ PISTON REMOVAL/INSTALLATION	13-3	ROTOR DISASSEMBLY/ASSEMBLY (T, KW TYPE)	15-6
CRANKCASE COVER/CYLINDER BARREL/PISTON/ CONNECTING ROD/CRANKSHAFT/CAMSHAFT INSPECTION	13-6	SERIAL NUMBER LOCATION	1-2
CRANKSHAFT BEARING/ OIL SEAL REPLACEMENT	13-12	SPARK PLUG CAP INSPECTION	7-7
CYLINDER HEAD DISASSEMBLY/ASSEMBLY	12-4	SPARK PLUG CHECK/ADJUSTMENT/ REPLACEMENT	3-9
CYLINDER HEAD REMOVAL/INSTALLATION	12-3	SPARK TEST	7-7
CYLINDER HEAD/VALVES INSPECTION	12-5	SPECIFICATIONS	1-3
DIMENSIONAL DRAWINGS	1-5	THROTTLE CABLE CHECK/ADJUSTMENT	3-10
ENGINE IDLE SPEED CHECK/ADJUSTMENT	3-10	THROTTLE CABLE REMOVAL/ INSTALLATION	14-2, 14-3
ENGINE OIL CHANGE	3-4, 3-7	THROTTLE LEVER DISASSEMBLY/ASSEMBLY	14-6
ENGINE OIL LEVEL CHECK	3-3	TOOL	5-2
ENGINE REMOVAL/INSTALLATION	10-2	TOOLS	
ENGINE STOP SWITCH REMOVAL/INSTALLATION	7-8	CYLINDER HEAD	12-2
ENGINE TROUBLESHOOTING	4-3	ROTOR/TRANSMISSION	15-2
FLOAT CHAMBER INSPECTION	5-10	SERVICE INFORMATION	2-5, 13-2
FLOAT VALVE INSPECTION	5-9	TORQUE VALUES	2-3
FLYWHEEL REMOVAL/INSTALLATION	7-4	TRANSMISSION DISASSEMBLY/ASSEMBLY	15-10
FRAME TROUBLESHOOTING	4-3	TRANSMISSION OIL LEVEL CHECK	3-6
FUEL TANK AND STRAINER CLEANING	3-15	TRANSMISSION REMOVAL/INSTALLATION	15-9
FUEL TANK REMOVAL/INSTALLATION	5-3	TUBE ROUTING	2-8
FUEL TUBE CHECK	3-15	VALVE CLEARANCE CHECK/ADJUSTMENT	3-14
GENERAL SYMPTOMS AND POSSIBLE CAUSES	4-2	VALVE GUIDE REAMING	12-10
GOVERNOR DISASSEMBLY/ASSEMBLY	6-4	VALVE GUIDE REPLACEMENT	12-9
GREASE APPLICATION	3-8	VALVE SEAT RECONDITIONING	12-11
HANDLE ASSEMBLY REMOVAL/INSTALLATION	14-2	WHEEL/FRONT WEIGHT/REMOVAL/ INSTALLATION	16-2
		WIRING DIAGRAM	1-7